



# GT1175 Surface Mount with Wall Track Installation Manual

P/N C-00104 Rev 3-2-17

Nabco Entrances Inc. 582 W18717 Gemini Drive Muskego, Wisconsin 53150  
Phone: (877) 622-2694 Fax: (888) 679-3319 www.nabcoentrances.com  
NABCO hours of Operation: Monday to Friday 8:00 a.m.- 4:30 p.m. (Central Time)

*Associated Manuals Part Numbers: GT 1175 Electrical Installation Manual \*\*with U30 Microprocessor Controller (P/N C-00198)  
U30 Microprocessor Control Setup and Programming Manual (P/N C-00203)  
Slide Door Owner’s Manual (P/N C-00109) for Decal Installation  
“NABCO Price Book” for Common Sensors, Switches and Accessories (P/N 16-9244-30)*

## WARNING

- Turn OFF all power to the Automatic Door if a Safety System is not working.
- Instruct the Owner to keep all power turned OFF until corrective action can be achieved by a NABCO trained technician. Failure to follow these practices may result in serious consequences.
- NEVER leave a Door operating without all Safety detection systems operational.

## Table of Contents

**CHAPTER 1: WARNING LABELS ..... 3**

**CHAPTER 2: GENERAL SAFETY RECOMMENDATIONS ..... 3**

**CHAPTER 3: SCOPE ..... 4**

SECTION 3.1: To the Installer ..... 4

SECTION 3.2: Objective ..... 4

**CHAPTER 4: GETTING STARTED ..... 4**

SECTION 4.1: Types of Units ..... 4

SECTION 4.2: Header Configuration ..... 4

SECTION 4.3: Header Components ..... 5

SECTION 4.4: Remove the Header Cover ..... 5

**CHAPTER 5: INSPECT THE ROUGH OPENING ..... 6**

**CHAPTER 6: INSTALL THE DOOR FRAME ..... 6**

**CHAPTER 7: INSTALL THE WALL TRACK ..... 6**

**CHAPTER 8: WIRE THE ROCKER SWITCH ..... 7**

**CHAPTER 9: INSTALL THE BOTTOM GUIDE ASSEMBLY ..... 7**

**CHAPTER 10: INSTALL THE SLIDE DOOR ..... 8**

**CHAPTER 11: INSTALL WEATHERING ..... 10**

**CHAPTER 12: INSTALL THE GLASS STOPS ..... 11**

**CHAPTER 13: GLAZING (HEAVY/WIDE DOORS) ..... 11**

**CHAPTER 14: ADJUSTMENTS ..... 12**

**SERVICE PARTS: HEADER ..... 14**

**SERVICE PARTS: WALL TRACK ..... 17**

**SERVICE PARTS: LEFT HAND WALL TRACK FRAME ..... 18**

**SERVICE PARTS: RIGHT HAND WALL TRACK FRAME .....19**

**SERVICE PARTS: SLIDE DOOR.....21**

**SERVICE PARTS: LEFT HAND SLIDE DOOR .....22**

**SERVICE PARTS: RIGHT HAND SLIDE DOOR.....23**

**SERVICE PARTS: GLASS STOPS, AND VINYL.....26**

## CHAPTER 1: WARNING LABELS

Warning labels are universal and used to alert an individual of potential harm to one's self or to others. The following warning labels are listed in a hierarchy order that defines the most potential danger first, and the least potential danger last. Please refer to this page in the event that a warning label is displayed within this manual and further definition needs to be explained.

### **DANGER**

Indicates potentially dangerous situations. Danger is used when there is a hazardous situation where there is a *high* probability of severe injury or death. It should not be considered for property damage unless personal injury risk is present.

### **WARNING**

Indicates a hazardous situation which has *some* probability of severe injury. It should not be considered for property damage unless personal injury risk is present.

### **CAUTION**

Indicates a hazardous situation which *may result in a minor injury*. Caution should not be used when there is a possibility of serious injury. Caution should not be considered for property damage accidents unless a personal injury risk is present.

**Attention:** A situation where material could be damaged or the function impaired.

**Notice:** Indicates a statement of company policy as the message relates to the personal safety or protection of property. Notice should not be used when there is a hazardous situation or personal risk.

*Note:* Indicates important information that provides further instruction.

## CHAPTER 2: GENERAL SAFETY RECOMMENDATIONS

### **WARNING**

Do not install, operate or service this product unless you have read and understand the General Safety Recommendations, Warning Labels, contained in this manual. Failure to do so may result in bodily injury, or property damage.

### **WARNING**

Read, study and understand the installation and operating instructions contained in, or referenced in this manual before operating. If you do not understand the instruction, ask a qualified technician. Failure to do so may result in bodily injury, or property damage and will nullify all warranties.

### **DANGER**

Disconnect all power to the junction box prior to making any electrical connections. Failure to do so may result in serious personal or fatal injury. When uncertain whether power supply is disconnected, always verify using a voltmeter.

### **DANGER**

Do not place finger or uninsulated tools inside the electrical controller. Touching wires or other parts inside the enclosure may cause electrical shock, serious injury or death.

### **CAUTION**

The Ground wire from the Magnum IV Control 120 VAC Harness, and the Incoming 120 VAC Ground wire must be connected to the Ground screw located within the Swing door Header.

### **CAUTION**

If the door appears broken or does not seem to work correctly, it should be immediately removed from service until repairs can be carried out or a qualified service technician is contacted for corrective action.

**Notice:** This manual, the owner's manual and all other associated manuals must be given to and retained by the purchasing facility or end user.

**Notice:** Wiring must meet all local, state, federal or other governing agency codes.

**Notice:** All electrical troubleshooting or service must be performed by qualified electrical technicians and must comply with all applicable governing agency codes.

*Note:* All Adjustments must be made with a small screwdriver. Do Not use a pencil.

*Note:* Do Not take shortcuts.

## CHAPTER 3: SCOPE

### SECTION 3.1: To the Installer

The purpose of this manual is to familiarize the installer and purchaser with the proper installation and operation of this system. It is essential that this equipment be properly installed and operational before the door is used by the public. It is the installer's responsibility to inspect the operation of the entrance system to be sure it complies with any applicable standards. In the United States, ANSI Standard 156.10 covers the GT-1175 Slide Door System. Other local standards or codes may apply. Use them in addition to the ANSI standard. The GT-1175 is listed with the Underwriters Laboratory and is identified as such on the label. Instruct the building owners and operator on the essentials of the operation of the door and this device. The owner should follow these instructions to determine whether the door is operating properly and should immediately call for service if there is any malfunction. All installation changes and adjustments must be made by qualified, NABCO trained technicians.

### SECTION 3.2: Objective

The GT-1175 Standard Slide Door system is designed to be installed within a Rough Opening of a Building. The door function is controlled by the U30 Microprocessor Control. This control offers many features to accommodate most installation options. This manual offers step by step instructions.

#### CAUTION

**A pedestrian Door that does not have its glass sections installed at the Factory shall specify that the glazing material employed is to comply with the requirement in UL 325 par.29.5.1:**

**“The glazing material in both fixed and sliding panels of all sliding doors and in all unframed swinging doors shall comply with the requirements in the Performance Specifications and Methods of Test for Safety Glazing Material Used in Buildings, ANSI Z97.1. Glazing material for other pedestrian doors shall also comply with ANSI Z97.1, except that single strength or heavier glass may be used for those portions of doors involving a glazed area of less than 1ft<sup>2</sup> (0.9 m<sup>2</sup>) and having no dimension greater than 18 in (457 mm)”.**

## CHAPTER 4: GETTING STARTED

### SECTION 4.1: Types of Units

- ▶ Mechanical Configurations:
  - Single Slide: (1) Slide Door that slides to the right or left with (1) Sidelite Panel.
  - Bi-Part: (2) Slide Doors that slide apart from the center with (2) Sidelite Panels.
- ▶ Emergency Egress:
  - Full Open: Both the Slide door and Swing Sidelite break out for emergency egress.
  - Fixed Sidelite: Secured to the Header and Jamb Tube. Only the Slide door breaks out for emergency egress.

### SECTION 4.2: Header Configuration

Components within the Header are laid out in (1 of 3) different configurations to ensure proper operation of the Drive Belt. However, no matter the configuration, the Power Supply must never be installed between the U30 Microprocessor Control and the Operator. Please see details listed below:

- ▶ Operator/Control/Power: Header Width is not wide. Operator needs to be installed to the left of the U30 Control.

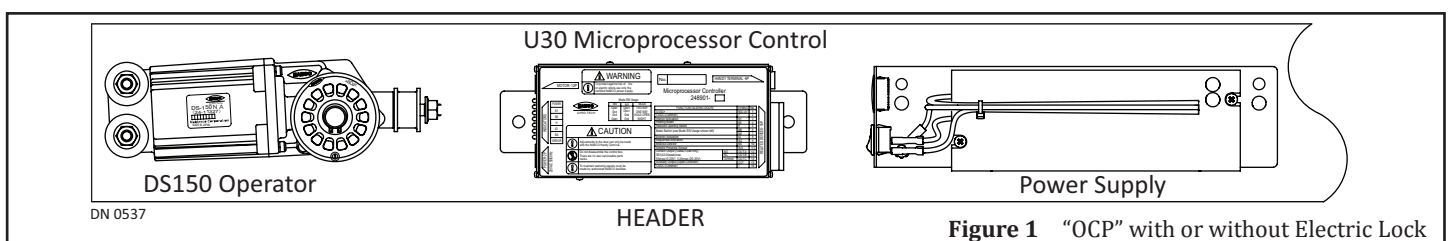

- ▶ Power/Operator/Control: Header Width is wide, but Operator still needs to be installed between the Power Supply and the U30 Control.

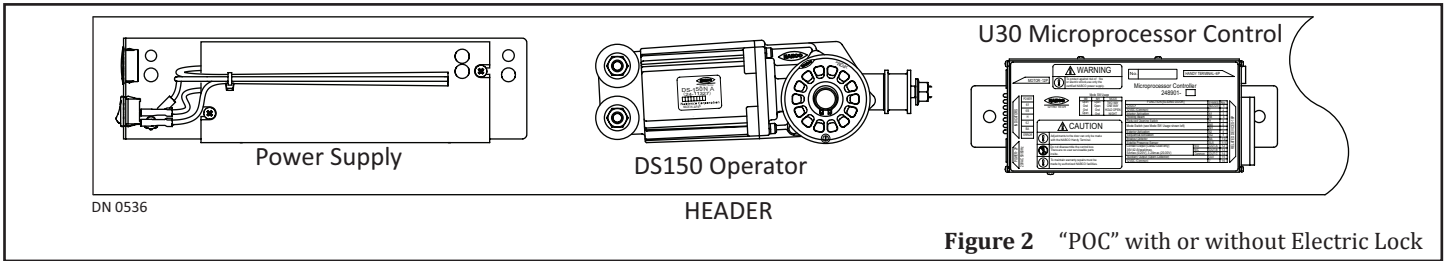

Figure 2 “POC” with or without Electric Lock

- ▶ Power/Control/Operator: Header Width is wider. Operator can be installed to the right of the Power Supply and the U30 Control.

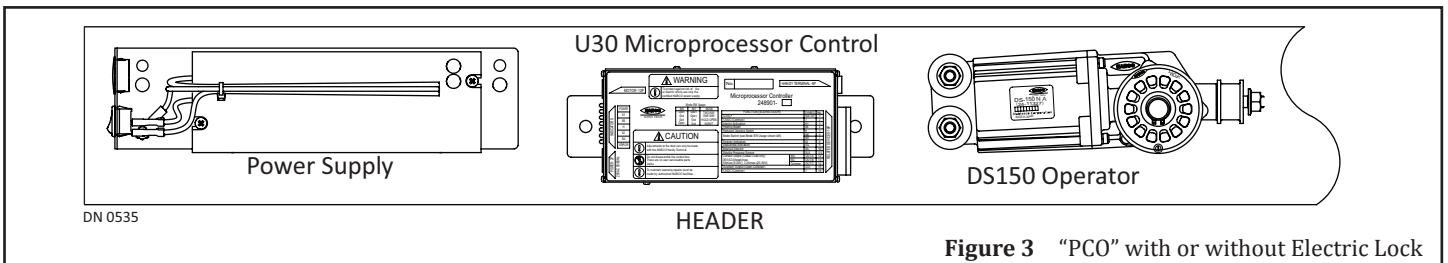
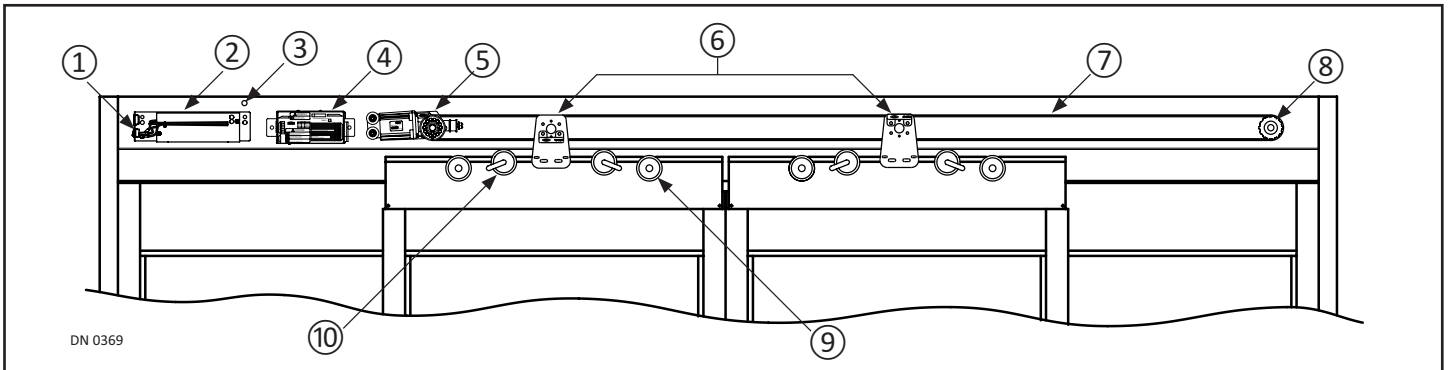

Figure 3 “PCO” with or without Electric Lock

**SECTION 4.3: Header Components**



1	Power Cut Off Switch	N/A	6	Belt Clip Assembly	A-00759
2	DS 150/U30 Power Supply	A-00717	7	Timing Belt 3/4" wide	M-01491
3	Handy Terminal Harness	M-01517	8	Idler Assembly	A-00042
4	U30 Microprocessor Control	V-00020	9	Anti Rise Roller	A-00163
5	DS 150 Operator	M-00395	10	Hanger Roller	A-00162

**SECTION 4.4: Remove the Header Cover**

1. Remove (2) 8-32x0.625L Flat head screws. Remove Header Cover by lifting it up and then pulling it out.
2. Unplug the Sensor (if equipped). Remove Parts boxes and/or Parts bags from inside Header.

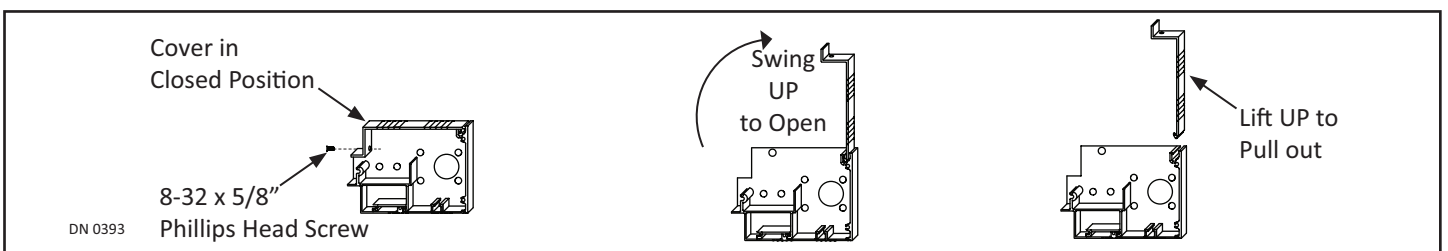

## CHAPTER 5: INSPECT THE ROUGH OPENING

1. Ensure the Rough Opening is correct size.
  - ▶ The width of the Rough Opening should equal: **PACKAGE WIDTH + 1/4 INCH ON EACH SIDE**
  - ▶ The height of the Rough Opening should equal: **PACKAGE HEIGHT + 1/4 INCH**

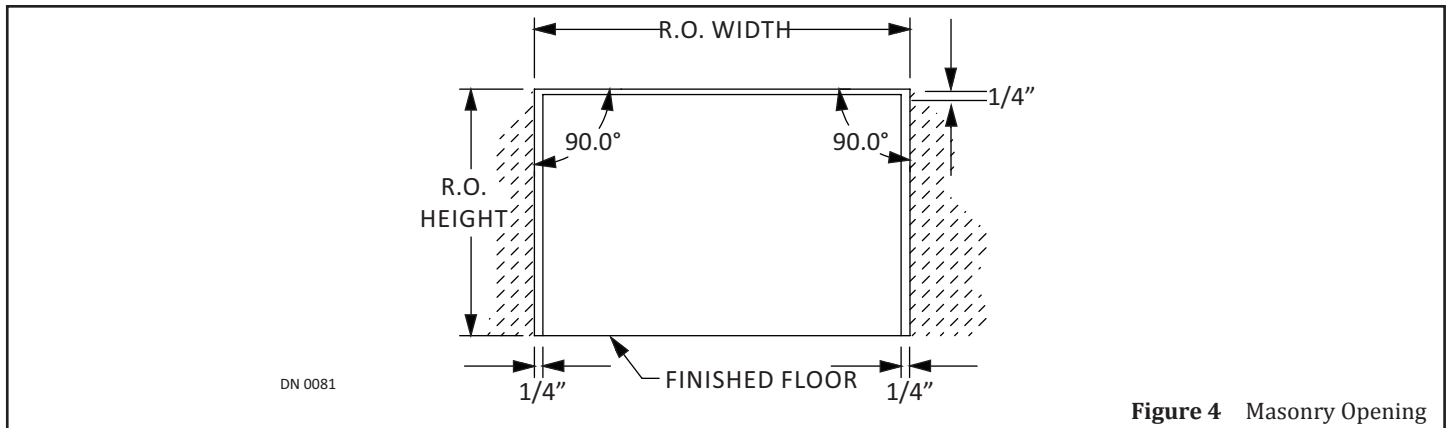

Figure 4 Masonry Opening

*Note: Make allowances for tile or other existing materials that may change the floor height.*

2. Ensure the floor is level across the entire opening.

## CHAPTER 6: INSTALL THE DOOR FRAME

1. Position Jamb Tubes on either side of Header according to the instruction sticker located on each Jamb Tube, showing proper location and orientation.
  - a. Ensure the removable cover side of Header is facing up.
2. Orientate the Frame in relation to the building:
  - a. Frame must be secured on Exterior Side of Building. Side of Header with removable Cover must also face Exterior side.

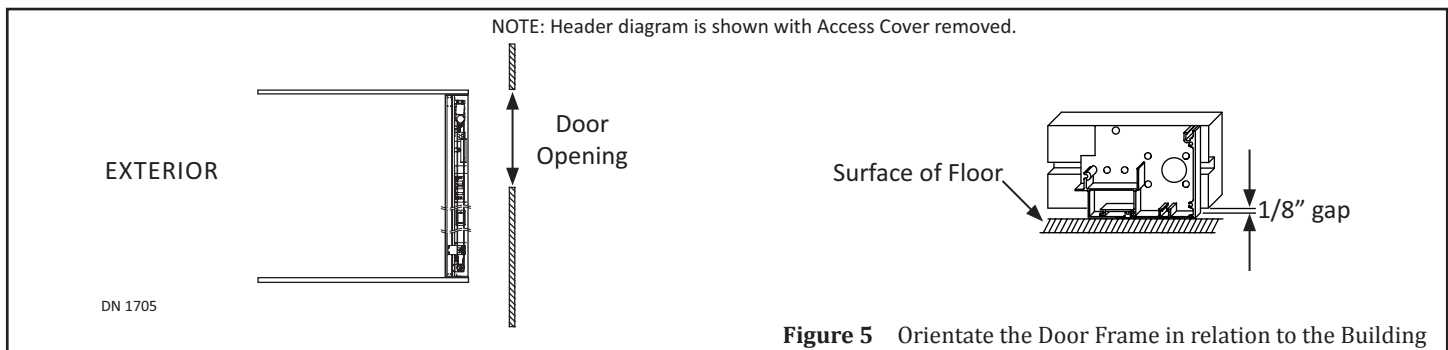

Figure 5 Orientate the Door Frame in relation to the Building

3. Secure the Header to each Jamb Tube with (6) 1/4-20 x .75 Whizlock screws.
  - a. If installed correctly there will be a 1/8 inch gap between the bottom of Jamb Tubes and the flat surface.
4. Position the Door Frame so the Slide Door can fully open without obstruction and is square/level across the surface of floor.
5. Mark and drill 1/4" diameter holes on the inside face of Header every 10 - 12" (minimum).
6. Secure the Header to the surface of building with 1/4" anchors (not provided by NABCO).

## CHAPTER 7: INSTALL THE WALL TRACK

1. Position the Bottom Rail so the side with a 3/4 inch gap across the bottom faces the breakout side of the building.
2. Slide the Bottom Rail onto the Muntin Clip located on the Pivot Jamb Tube.
3. Go to the Header. Locate the pre-installed Mounting Clip located at the bottom.
4. Tilt the Vertical Mullion so the Header Mounting Clip can slide into the opening. At the same time slide the Muntin Clip into the Bottom Rail.

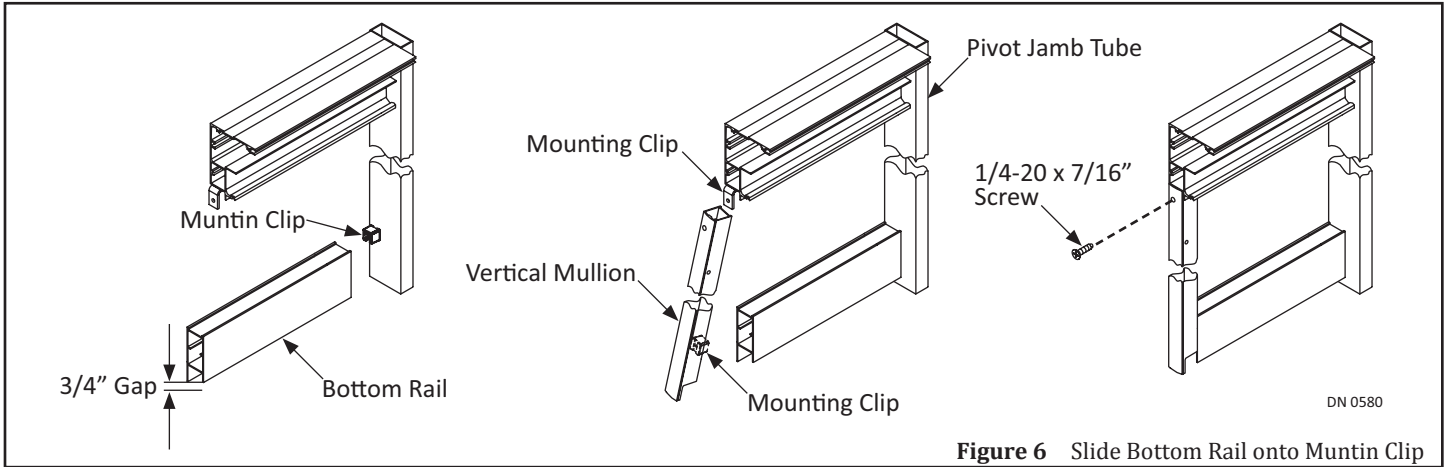

Figure 6 Slide Bottom Rail onto Muntin Clip

### CHAPTER 8: WIRE THE ROCKER SWITCH

Note: Do not secure the Switch Assembly to the Jamb Tube until after the Slide door installation is complete.

Note: The U30 Microprocessor Control, Main Harness comes in three lengths: 36 inches, 72 inches, and 80 inches.

Note: An optional Key Switch is installed the same way as the Rocker Switch.

1. Remove the Rocker Switch and (2) screws from the Jamb Tube.
2. There is approximately (2) feet of Cable Wiring connected to the Main Harness inside the Header. Withdraw the Cable Wiring through a hole at the bottom Lip of Header. Continue to route the Cable Wiring through the top of Jamb Tube, then down to where the Rocker Switch was removed.
3. Pull the Cable Wiring through the cut out. Connect the Cable Wiring to the Rocker Switch Harness.
4. Secure the Rocker Switch to the Jamb Tube with (2) screws, after the Slide Door installation is complete.

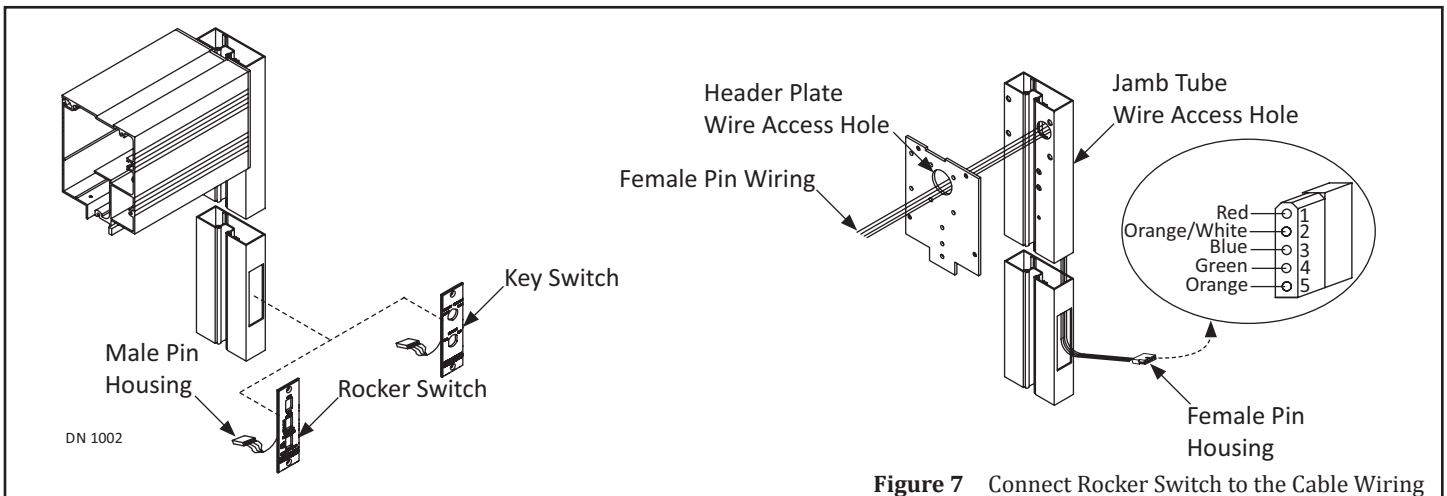

Figure 7 Connect Rocker Switch to the Cable Wiring

### CHAPTER 9: INSTALL THE BOTTOM GUIDE ASSEMBLY

1. Remove the Bottom Guide Cover Plate from the bottom of the Strike Stile.

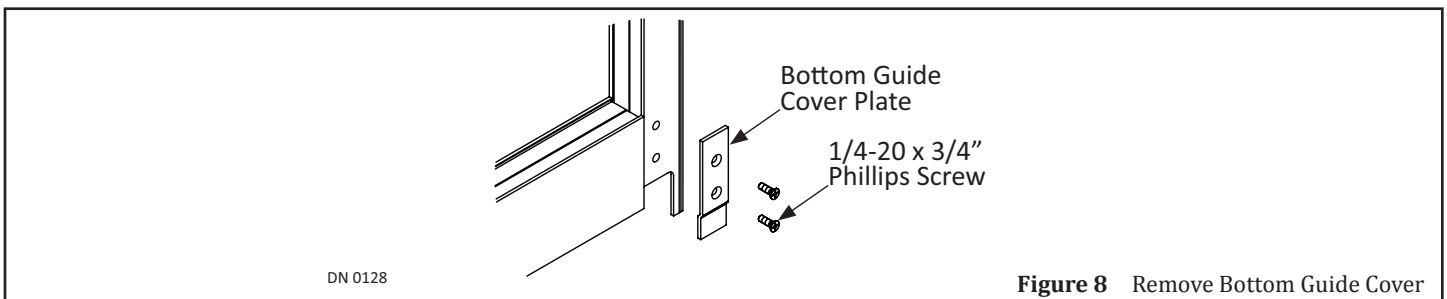
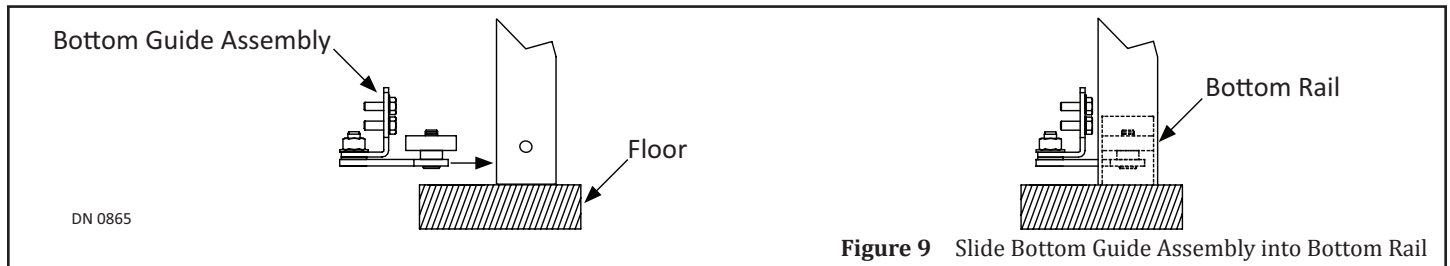

Figure 8 Remove Bottom Guide Cover

2. Install the Bottom Guide Double Roller Assembly by sliding (2) rollers into the Bottom Rail so the Bracket sticks out from underneath (in direction of where the Slide door is to be installed).
3. Use the Bracket to slide the Bottom Guide Double Roller Assembly towards the Pivot Stile. Replace the Cover Plate.



## CHAPTER 10: INSTALL THE SLIDE DOOR

**CAUTION**

Do not test Breakout until all adjustments are made and doors are secured.

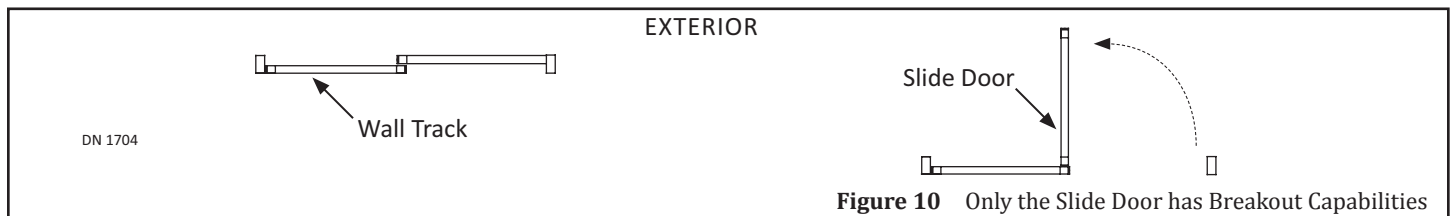

1. Go to the Carrier on top of Slide Door.

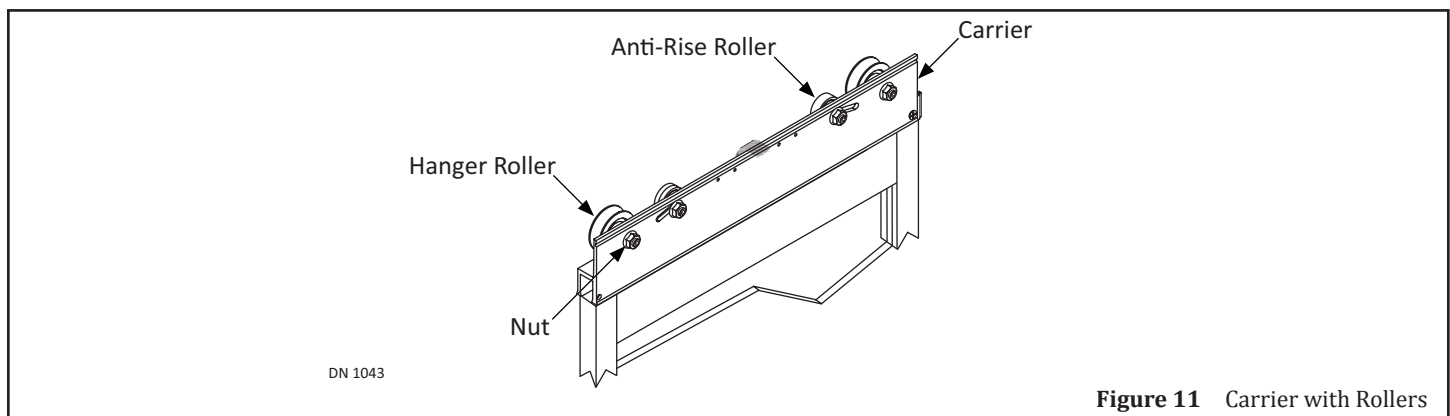

**CAUTION**

Do not rotate the Roller Axle counter-clockwise. Doing so will unthread the Axle from the Roller Assembly.

2. Loosen (1) 7/16-20 Whiz Lock Nut on each Roller by inserting (1) 7/32" Allen wrench into the exposed end of a Roller Axle. Hold the 7/32 inch Allen wrench in place to keep the Roller Axle stationary. At the same time, loosen (1) 7/16-20 Whiz Lock nut with a 15/16 inch Open End Wrench.

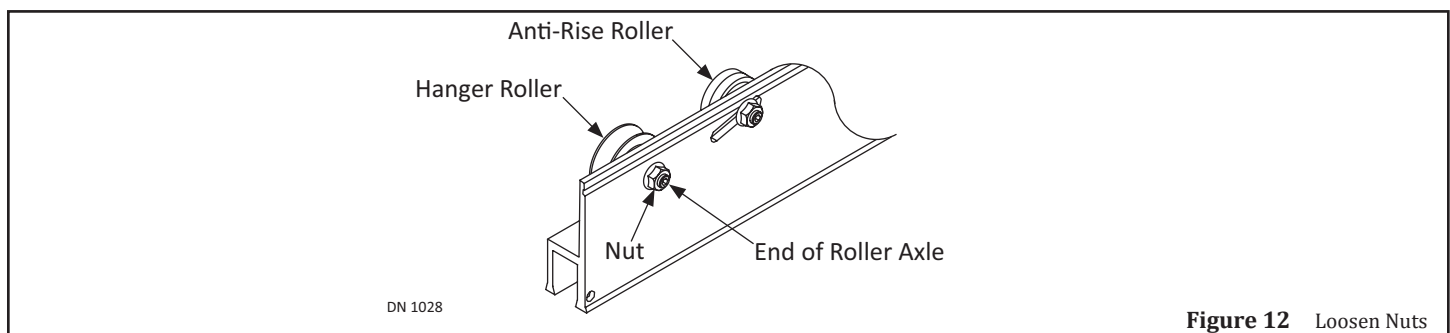



3. Lift and then slightly tilt the Slide door to place all (4) Rollers onto the track (located inside the Header).

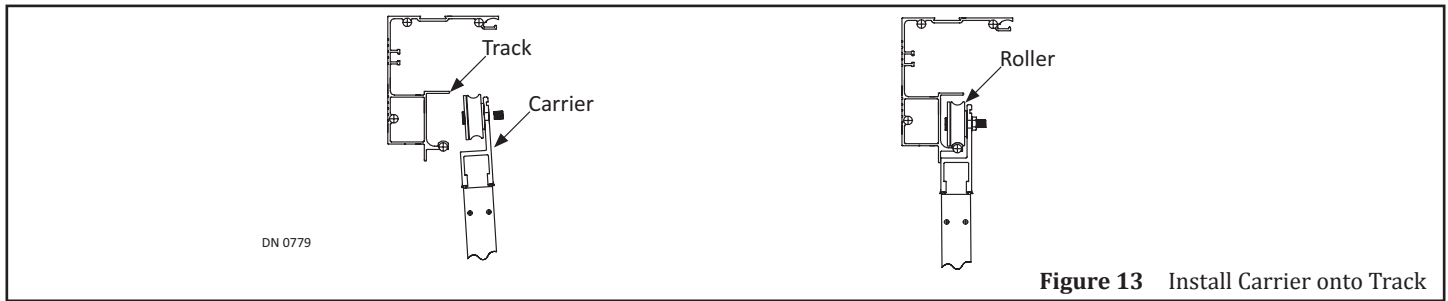

**Figure 13** Install Carrier onto Track

4. Secure the Belt Clip to the Carrier with (2) 1/4-20 x 3/4 inch Whiz-Lock screws.

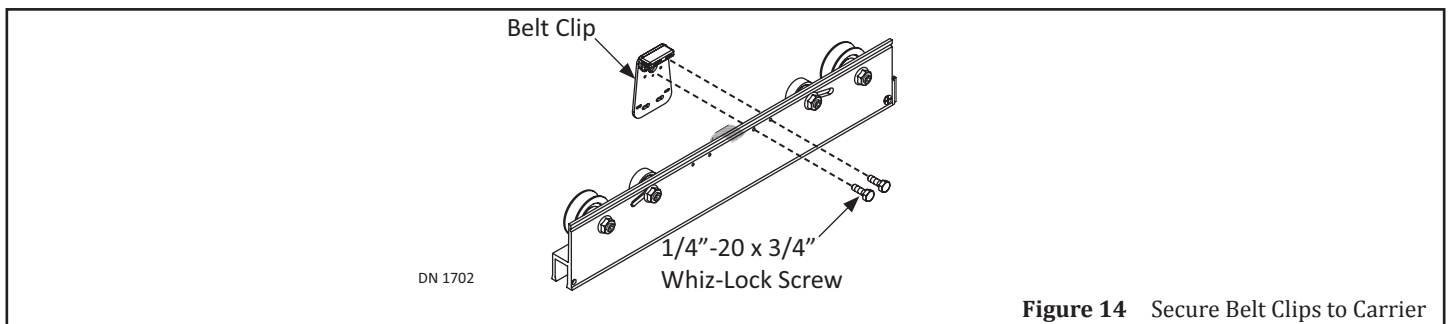

**Figure 14** Secure Belt Clips to Carrier

5. Locate the Bottom Guide Double Roller Assembly inside the Bottom Rail. The Bracket will be sticking out from underneath.

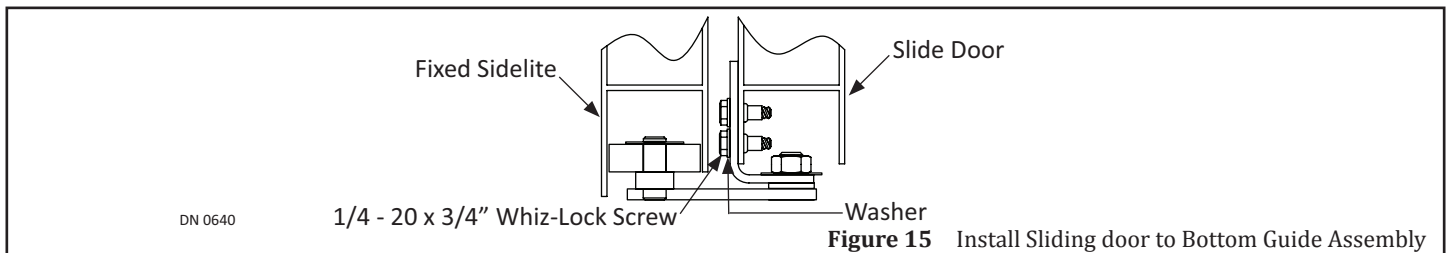

**Figure 15** Install Sliding door to Bottom Guide Assembly

6. Slide the Slide Door's Pivot Stile onto the Bracket.
7. Support the weight of the Fixed Sidelite.
8. Breakout the Slide door to Full Open position.
9. Secure the Bracket to the Pivot Stile with (2) 1/4 - 20 x 3/4 inch Whiz-Lock screws.

## SECTION 10.1: Adjust Rollers

### 10.1.1 Adjust Hanger Rollers

1. Raise or lower the Slide door by turning the Axle clockwise with a 15/16" Open End Wrench.
  - a. The appropriate gap between the Bottom Rail and floor is between 11/16 inch to 15/16 inch; with the nominal gap being 7/8 inch.

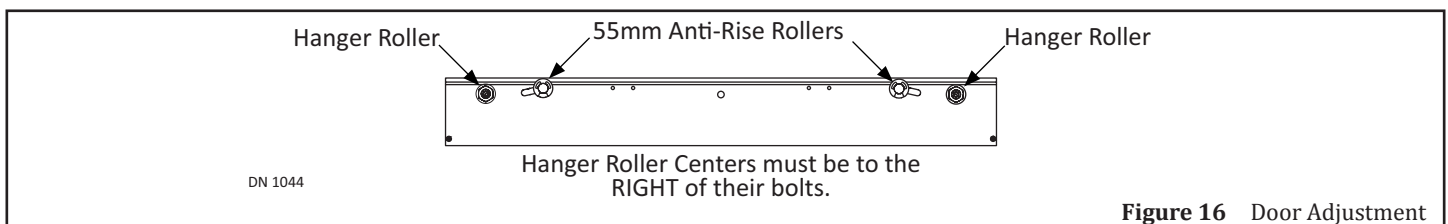
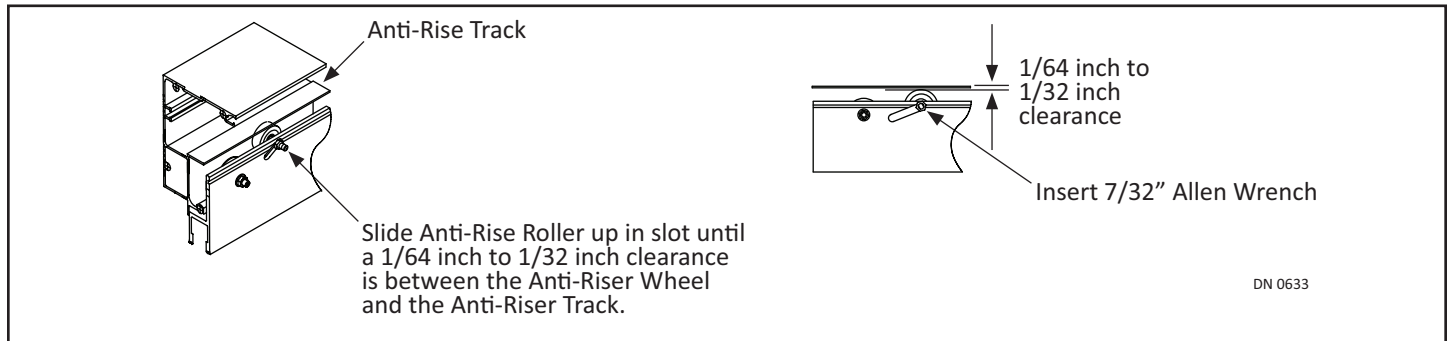

**Figure 16** Door Adjustment

2. Ensure the Leading Edge of the Slide door and Jamb Tube are parallel.
3. Tighten the 7/16-20 Whizlock nuts. Do not overtighten.

### 10.1.2 Adjust the Anti Rise Rollers

1. Loosen (2) Anti-Rise Rollers located towards the middle of the Carrier.
2. Slide the Anti-Rise Roller up or down within the slot until there is 1/64 inch to 1/32 inch gap between the Roller Wheel and the Top Track. The Gap should be about the same thickness as a credit card.
3. Tighten the 7/16-20 Whizlock nuts. Do not overtighten.



### 10.1.3 Tighten Rollers

1. Hold the 7/32 inch Allen wrench in place to keep the Roller Axle stationary. At the same time, tighten each (1) 7/16-20 Whiz Lock nut with a 15/16 inch Open End Wrench.

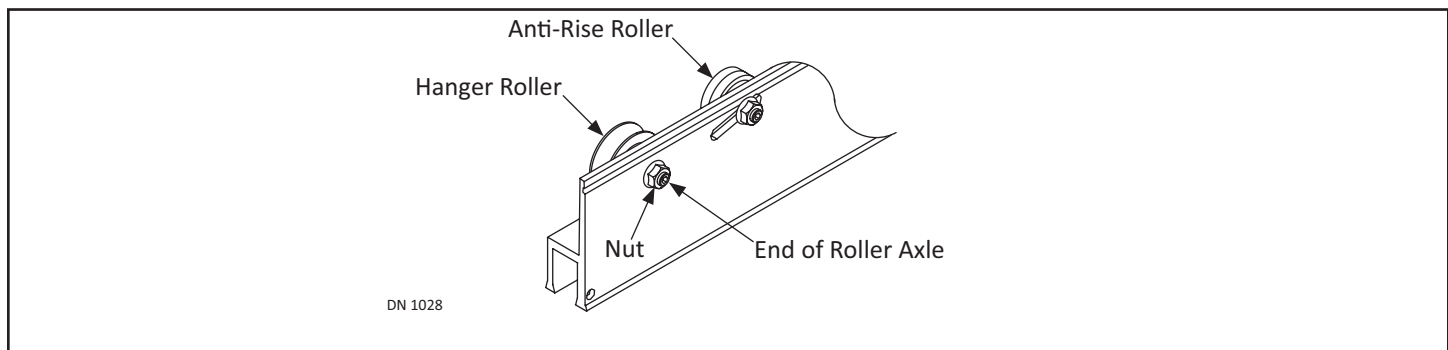

## CHAPTER 11: INSTALL WEATHERING

1. Install Brush by sliding it into the Brush Holder:
2. Secure the Brush Holder against the Bottom Rail of Slide door with (3) #6 x 1/2 inch self tapping screws.
3. Ensure the entire Door Frame is properly secured to the Rough Opening.
4. Apply caulking bead between the Door Frame and Rough Opening (inside and outside).
5. Apply Caulking between surface and Vertical Mullion.

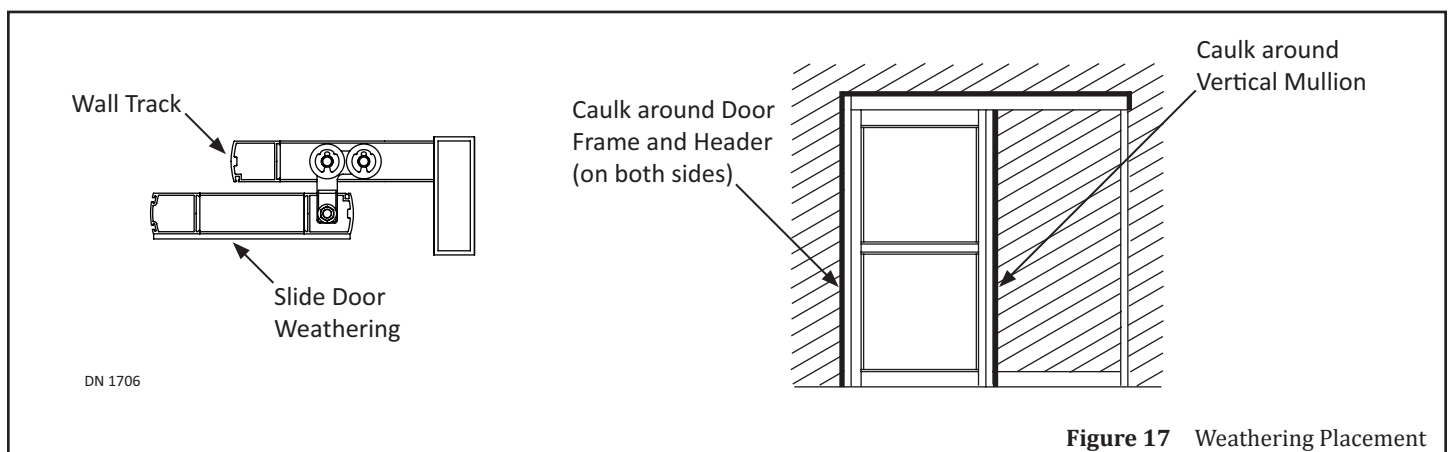

**Figure 17** Weathering Placement

## CHAPTER 12: INSTALL THE GLASS STOPS

**WARNING** Glazer must be fully trained and qualified. Failure to do so may result in bodily injury, or property damage.

*Note: Ensure the installation area is free of debris and/or sharp objects. Failure to do so may damage the glass or contaminate the glazing process.*

### SECTION 12.1: Door Panel

*Note: The Snap Base and Vinyl Seals/Gaskets are preinstalled at the NABCO Factory.*

1. Ensure the Snap Base is free of debris and/or sharp objects.
2. Install the Setting Blocks (not provided by NABCO) and Glass Panel.
3. Snap the Glass Stop into the Snap Base.

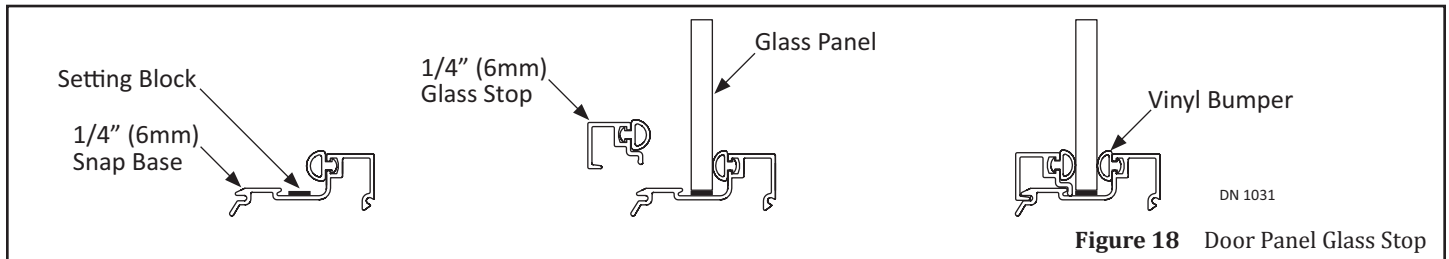

## CHAPTER 13: GLAZING (HEAVY/WIDE DOORS)

In accordance with standard glazing practices, Nabco recommends Cross-Blocking for maintaining square with heavy glass or wide Door Panels (Fixed and Full Open). Cross-Blocking helps direct glass weight away from the strike edge of the door, to prevent sagging and possibly dragging on the floor or threshold. If the Door Panel is not square and sags at the lead edge, increase the thickness of the Glazing Block (not provided by NABCO).

*Note: Only place Glazing Blocks in the designated marked spots.*

1. Go to the STRIKE side of door panel at the TOP.
  1. Measure (6) inches from the Bottom edge of Top Rail, towards the Pivot side of Door Panel. Mark that spot.
  2. Measure (6) inches from the Top Corner of the Strike Edge down to the bottom of the Door Panel. Mark that spot.
2. Go to the PIVOT side of door panel at the BOTTOM.
  1. Measure (6) inches from the Top edge of Bottom Rail, up to the top of Door Panel. Mark that spot.
  2. Measure (6) inches from the Center of Pivot, towards the Strike side of Door Panel. Mark that spot.
3. Place (1) Glazing Block (not provided by NABCO) between the Glass and Door Frame, at marked spots.
  - a. It may be necessary to use more than (1) Glazing Block.

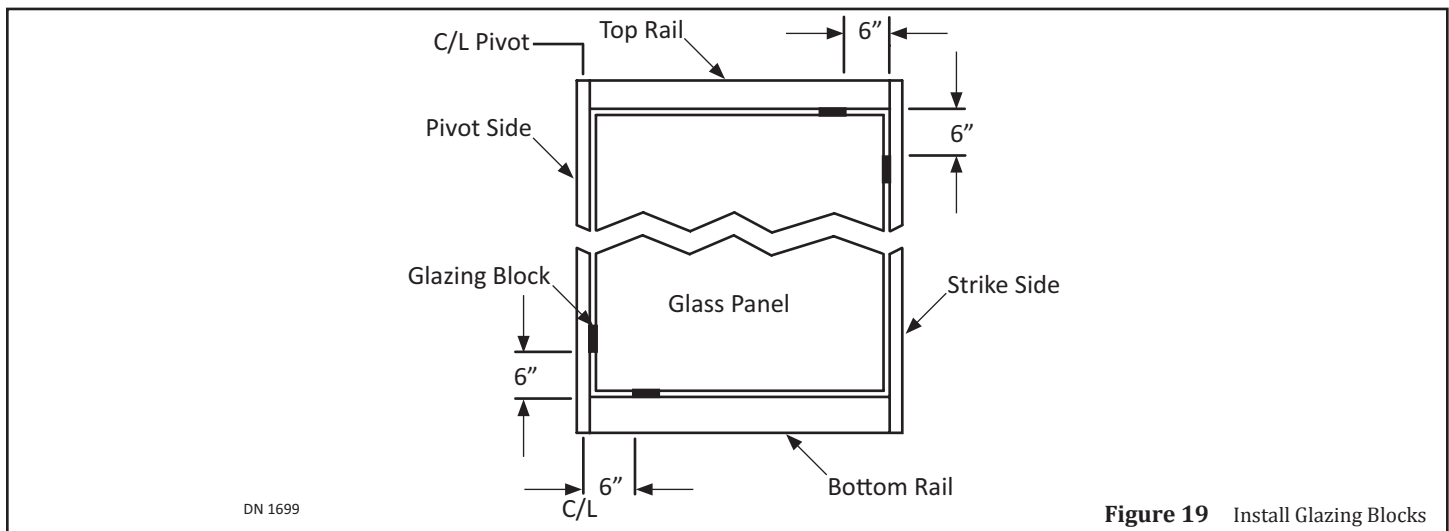
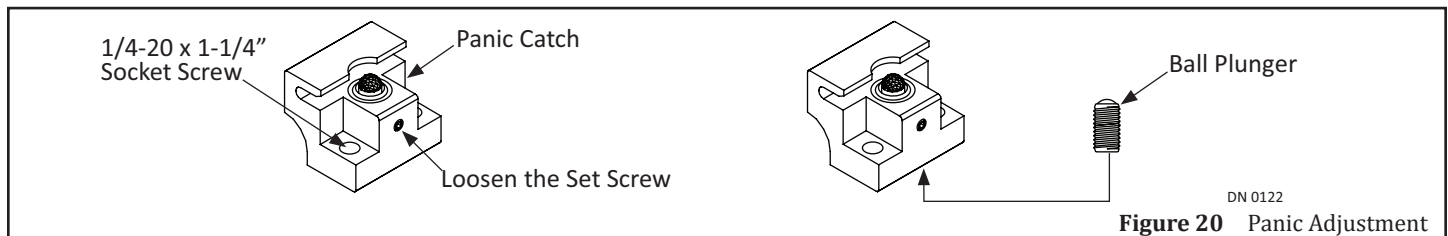

**Figure 19** Install Glazing Blocks

## CHAPTER 14: ADJUSTMENTS

### SECTION 14.1: Adjust the Ball Plunger

1. Breakout the Slide door. Go inside the Top Rail (closest to the Strike Stile). Remove the Panic Catch Assembly.



2. Loosen the Set screw that is located in front of the Panic Catch.
3. Go underneath the Panic Catch. Raise or lower the Ball Plunger to adjust the engagement.
  - a. The Ball Plunger must be adjusted for proper breakout resistance to meet ANSI A156.10 code and/or local code.
  - b. Use minimal engagement if Panic Hardware is used.
4. Tighten the Set screw. Secure the Panic Catch Assembly inside the Top Rail with (2) 1/4-20 x 1-1/4 inch Socket Head screws.

### SECTION 14.2: Adjust Preload

1. Support the weight of Slide Door, then Breakout Slide door approximately 5 degrees (just enough to expose the Preload Adjustment Screw located on back edge of door). Do not let Slide door push up against any other Door Panel.
2. Check for door sag. The Slide door should latch without having to be manually lifted.

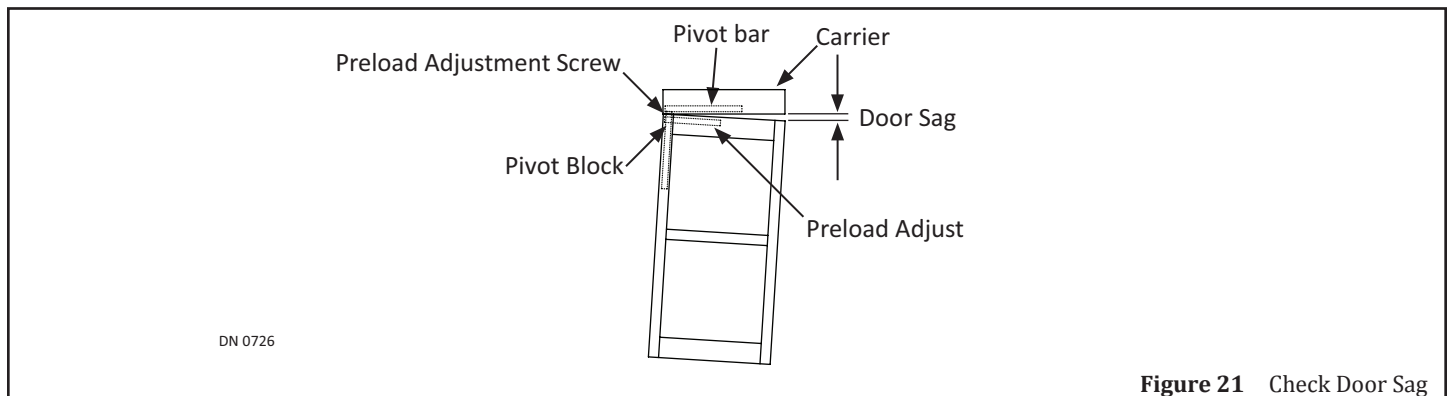

3. Go to the Preload Block located inside Top Rail. Loosen (2) Locking Bolts.
4. Go to the back edge of Pivot Stile. Reduce Door sag by tightening the 5/8 inch Set Screw with an 7/32 inch Allen Wrench. Do Not allow the Adjustment Set Screw to protrude more than 7/32 inch past the end of stile.
  - a. If deemed necessary, substitute the 5/8 inch Set Screw with the optional 1/2 inch Set Screw supplied by NABCO.

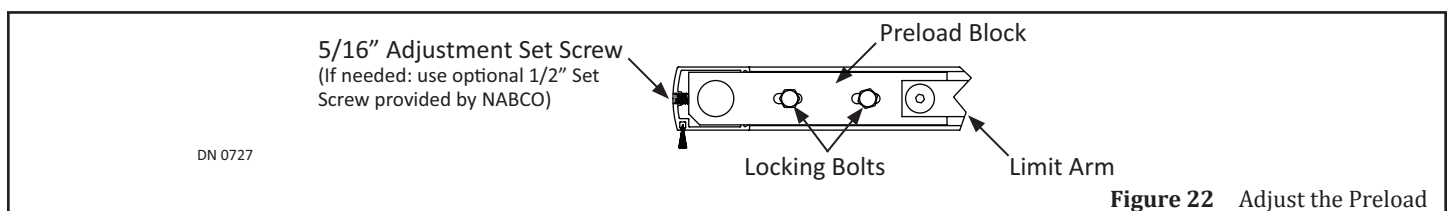

### SECTION 14.3: Correct Preload Misalignment

1. Break Open the Slide Door. Locate the Carrier Pivot Assembly inside the Top Door Web.
2. Loosen the 5/16-24 x 1/2 Set Screw located on the Pivot Stile at the Top.
3. Loosen (2) 1/4-20 x 1.75 Hex Screws used to secure the Carrier Pivot Assembly to the Top Door Web.
4. Slide the Carrier Bar to the left or right, until the Slide Door is aligned to the Carrier. Tighten all screws.

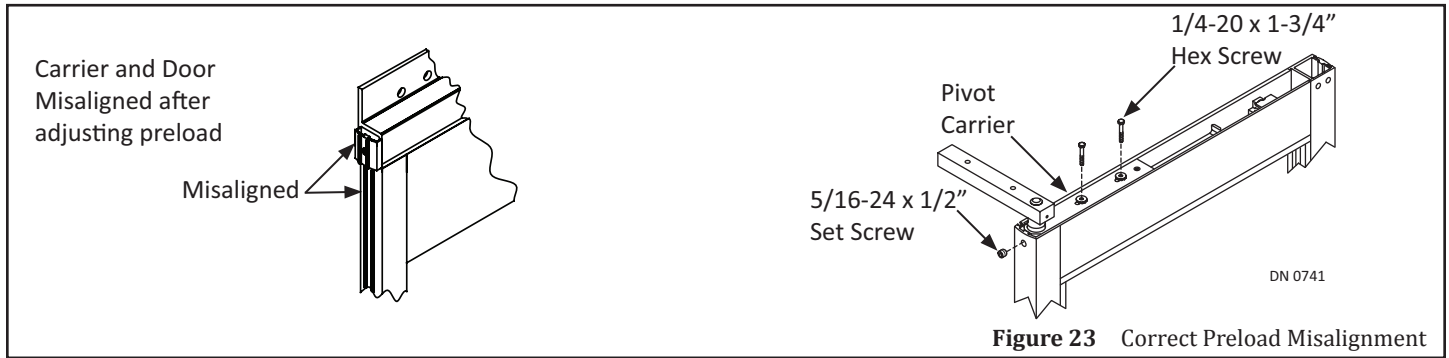

**Figure 23** Correct Preload Misalignment

5. Verify that the Lower Panic Catch inside the Door Web is still aligned to the Upper Panic Catch inside the Carrier. If an adjustment is necessary:
  1. Go to the Lower Panic Catch. Loosen (2) 1/4-20 X 1-1/4 inch Socket Screws used to to secure the Lower Panic Catch to the Door Web.
  2. Slide the Lower Panic Catch to the right or to the left until it is aligned to the Upper Panic Catch. Tighten Socket Screws.

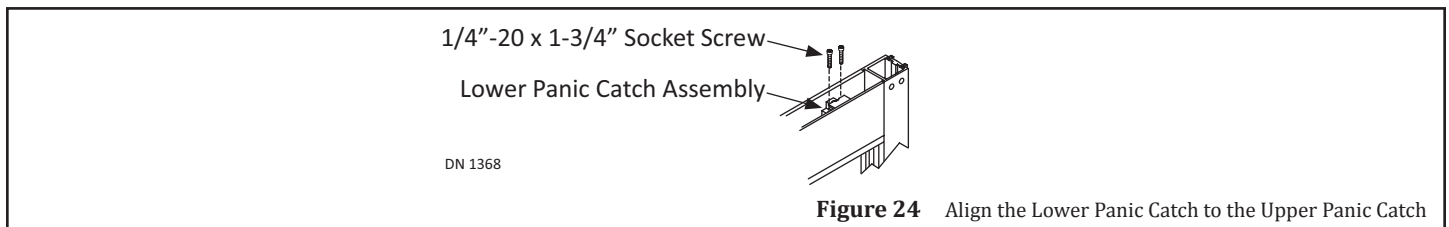

**Figure 24** Align the Lower Panic Catch to the Upper Panic Catch

**SECTION 14.4: Adjust the Breakout Magnet**

1. The Magnet is secured to the Limit Arm Bracket that can slide to the Left and Right. Slide the Breakout Magnet to the Left or to the Right until it is aligned with the Magnetic Reed Switch.
  - a. The Magnetic Reed Switch is a 3/8 inch diameter black circle located on the Bottom Lip of Header.

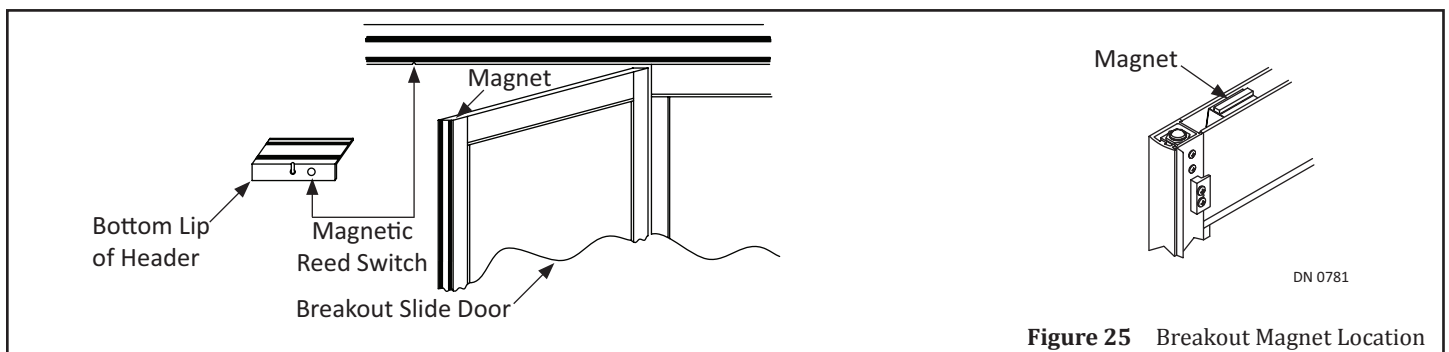

**Figure 25** Breakout Magnet Location

**SECTION 14.5: Units 54 Inches Wide (or greater) and/or over 200 Pounds**

1. Break Open the Slide door. Locate the Nose Caster that was pre-installed within the Strike Stile (Bottom Rail).
2. Loosen the #8-32 Set Screw. Position the Wheel so it is perpendicular to the Bottom Rail. Retighten the #8-32 Set Screw.
3. Fully close the Slide door. Ensure the Nose Caster does not hit or scrape the floor.

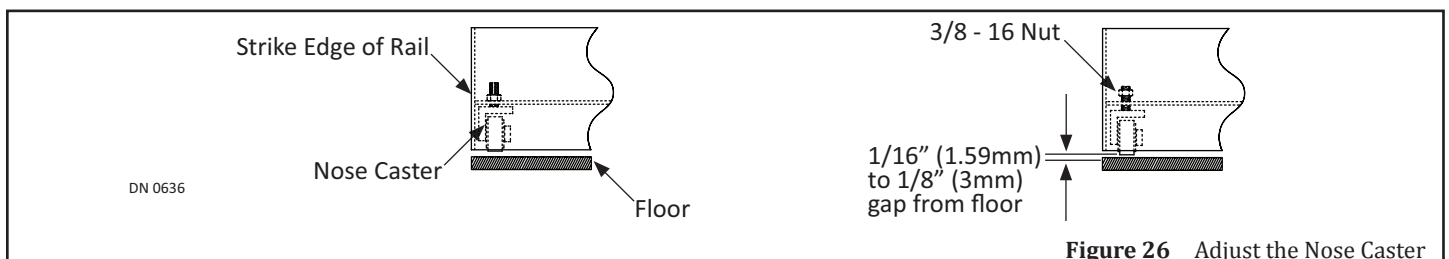

**Figure 26** Adjust the Nose Caster

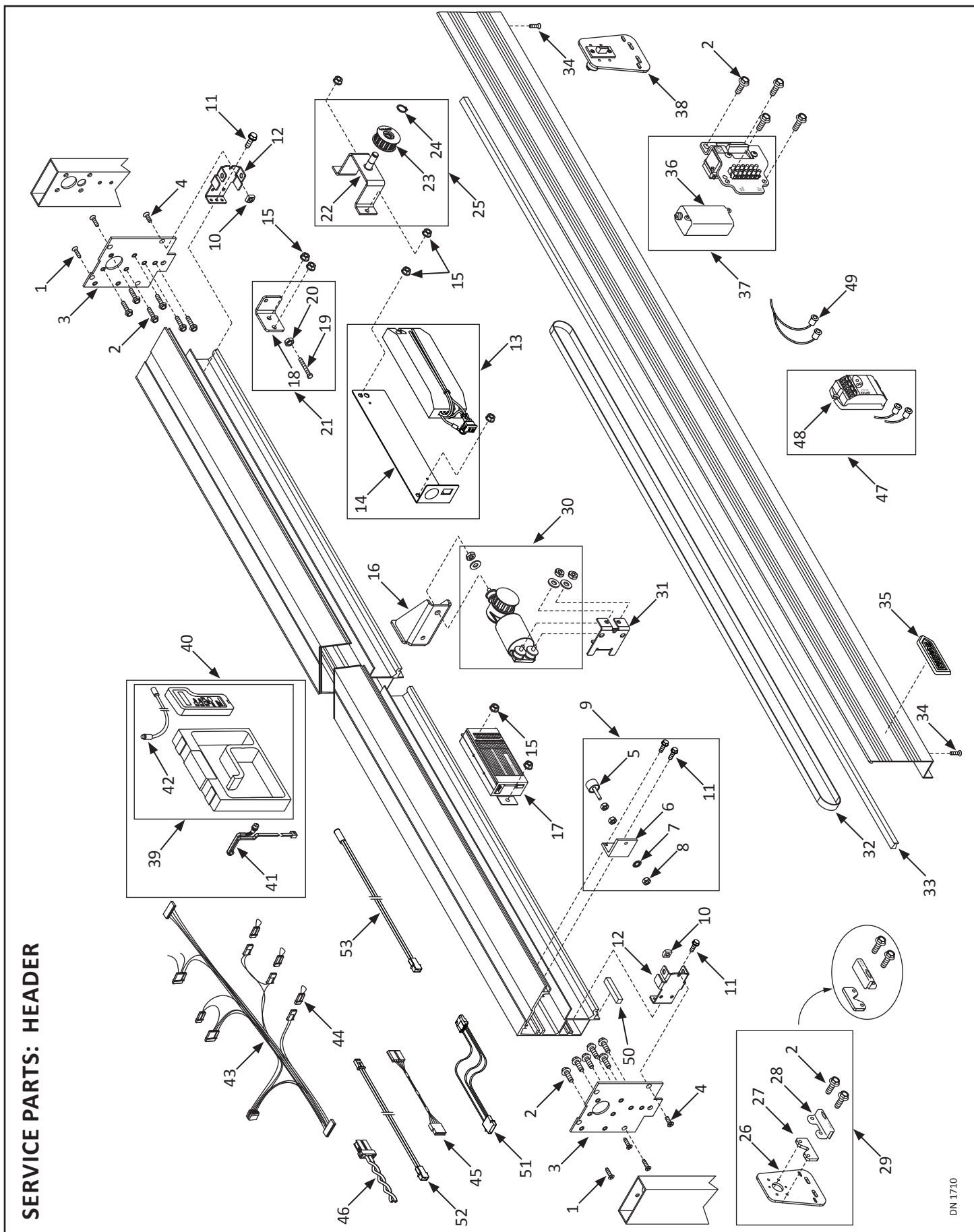

**SERVICE PARTS: HEADER**

DN 1710

Item	Part	Finish/Sizes/Notes	Description
1	T-00061		FHMS,1/4-20x1.000L.,PHIL,TRI-LOBE,ZINC
2	T-00010		HHCS,1/4-20x0.750L.,WHIZLOCK,ZINC
3	M-60582	Clear	END CAP,ONE PIECE HEADER,RH,204
	M-70582	Dark Bronze	END CAP,ONE PIECE HEADER,RH,313
	M-60574	Clear	END CAP,ONE PIECE HEADER,LH,204
	M-70574	Dark Bronze	END CAP,ONE PIECE HEADER,LH,313
4	T-00015	Zinc	FHMS,1/4-20x0.750L.,PHIL,ZINC
	T-00017	Black Zinc	FHMS,1/4-20x0.750L.,PHIL,BLK ZN
5	A-00087		BUMPER,DOOR STOP
6	M-00502		BRACKET, IDLER/STOP
7	T-00096		"WASHER,INT,1/4;ZINC"
8	T-00002		NUT,HEX,1/4-20,ZINC
9	A-00128		DOOR STOP,ASM.
10	T-00058		NUT,SQ.,1/4-20,ZINC
11	T-00023		HHSMS,14X0.750L,TEKS,ZINC
12	M-00411		BRACKET,END CAP,HEADER
13	A-00717		POWER SUPPLY,27 VDC,100 WATT
14	M-01624		"BRACKET,POWER SUPPLY,1175"
15	T-00025		NUT,WHIZLOCK,3/8-16,ZINC
16	M-00396		BRACKET, MOUNTING, FRONT, DS150
17	V-00020		CONTROLLER, U30
18	M-00502		BRACKET, IDLER/STOP
19	T-00075		HHCS,3/8-16x2.750L.,FULL THREAD,ZINC
20	T-00067		NUT,HEX,JAM,3/8-16,ZINC
21	A-00078		BELT,DRIVE,IDLER SPROCKET,TENSIONER
22	M-00402		BRACKET,PULLEY SHAFT WELDMENT
23	M-00405		IDLER PULLEY ASSEMBLY
24	T-00049		RING,RETAINING,EXT,15mm SHAFT,HD
25	A-00042		ASM, IDLER PULLEY
26	M-00394		BRACKET,BELT CLIP MOUNTING
27	M-00392		SPACER,BELT CLIP
28	M-00391		BELT,CLIP
29	A-00759		BELT CLIP KIT
30	M-00395		OPERATOR,DS150
31	M-00397		BRACKET,MOUNTING , REAR, DS150
32	M-01491		BELT: .500 PITCH: "H" PROFILE
33	M-00499		WEATHERING:PILE:.27W X .25H:W/ ADH & FIN
34	T-00024		FHMS,8-32x0.625L.,PHIL,F-POINT,ZINC
	T-00179		"FHMS,8-32x0.625L.,PHIL,BK.ZC.TYPE F"
35	C-00067		NAMEPLATE,NABCO LOGO
36	V-00022		POWER SUPPLY, 24VDC, 0.5A

Item	Part	Finish/Sizes/Notes	Description
37	A-00342	Fail Safe	LOCK, ELECTRIC,FAIL SECURE,1175
	A-00341	Fail Secure	LOCK, ELECTRIC,FAIL SAFE,1175
38	A-00343		BRKT,BELT,ELECTRIC LOCK,RHFS,LHFO,BP
	A-00344		BRKT,BELT,ELECTRIC LOCK,LHFS,RHFO
39	A-00711		"KIT,HANDY TERMINAL"
40	V-00356		HANDY TERMINAL
41	M-01517	78.75 inches	"HARNESS,HANDY TERMINAL"
42	M-01410		CABLE,HANDY TERMINAL
43	M-00413		HARNESS,U30,CONTROL
44	A-00385		BREAKOUT JUMPER
45	A-00967	36 inches	HARNESS;EXTENSION;ROCKER SWITCH;36IN.
	A-00968	72 inches	HARNESS;EXTENSION;ROCKER SWITCH;72IN.
	A-00969	180 inches	HARNESS;EXTENSION;ROCKER SWITCH;180IN.
46	M-00412		HARNESS,U30,POWER
47	A-00709	Control Box and Cable	HOLDING BEAM SYSTEM
48	A-00129	Control Box	AMPLIFIER, PHOTOEYE, OPTEX ASSY
49	V-00073	(1) Emit and (1) Detect w/ExtCbl	HOLDING BEAM,PHOTO ELECTRIC,W/ EXT CABLE
50	M-00281		FOAM WEATHERSTRIPPING ADHESIVE BACKED
51	M-01156	48 inches	HARNESS,ACCUSENSOR EXTEN.48" INTERIOR
	M-01168	24 inches	HARNESS,ACCUSENSOR EXTEN.24" INTERIOR
52	M-01073	90 inches	HARNESS,BREAK OUT SWITCH,90IN EXTENTION
	M-01136	35 inches	HARNESS,BREAK OUT SWITCH,35IN EXTENSION
53	A-00758	Full Open Sidelite only	SWITCHBREAKOUT



### SERVICE PARTS: WALL TRACK

Viewed from Break Out Side



DN 0591

# SERVICE PARTS: LEFT HAND WALL TRACK FRAME

Viewed from Break Out Side

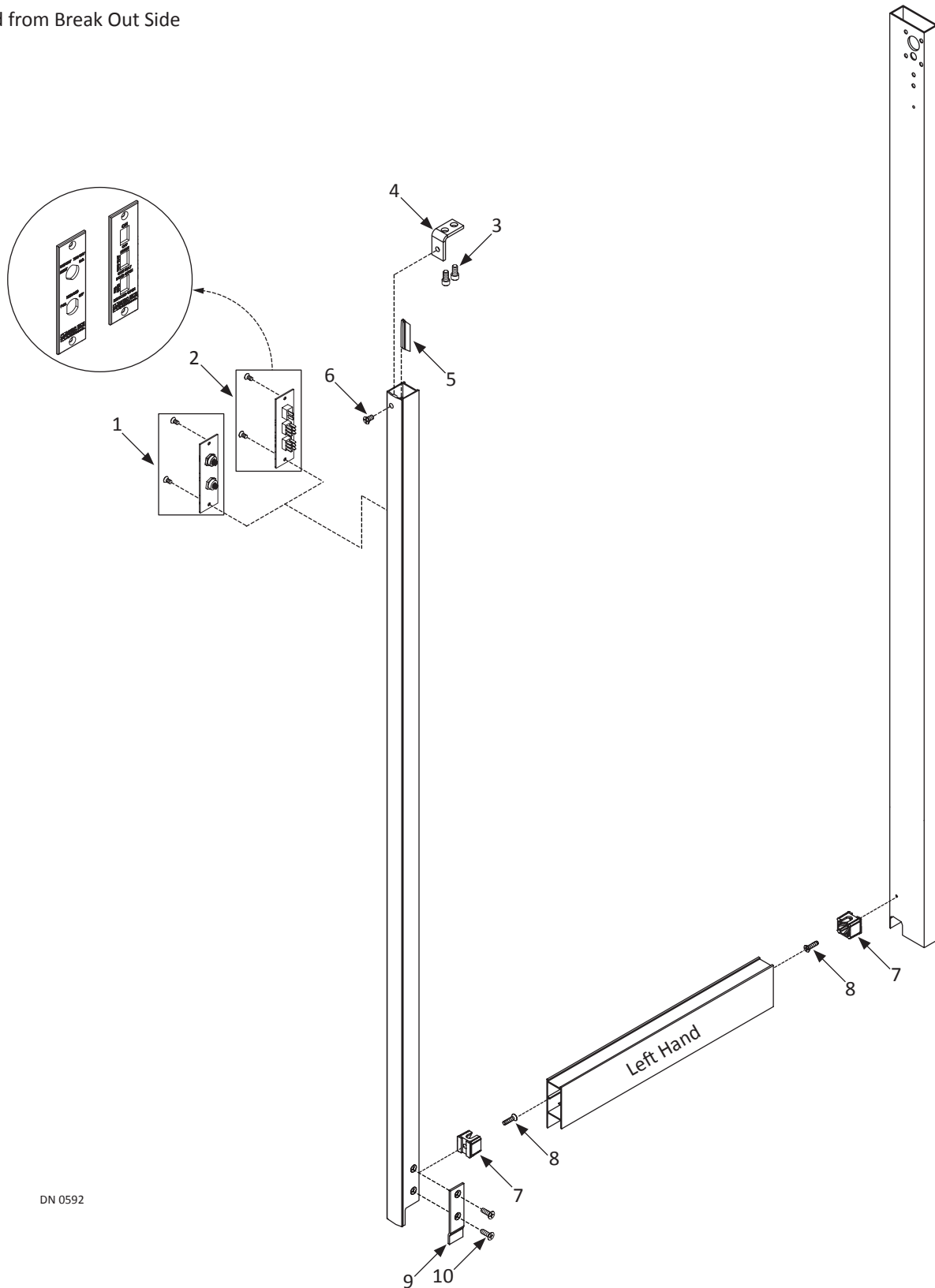

DN 0592

# SERVICE PARTS: RIGHT HAND WALL TRACK FRAME

Viewed from Break Out Side

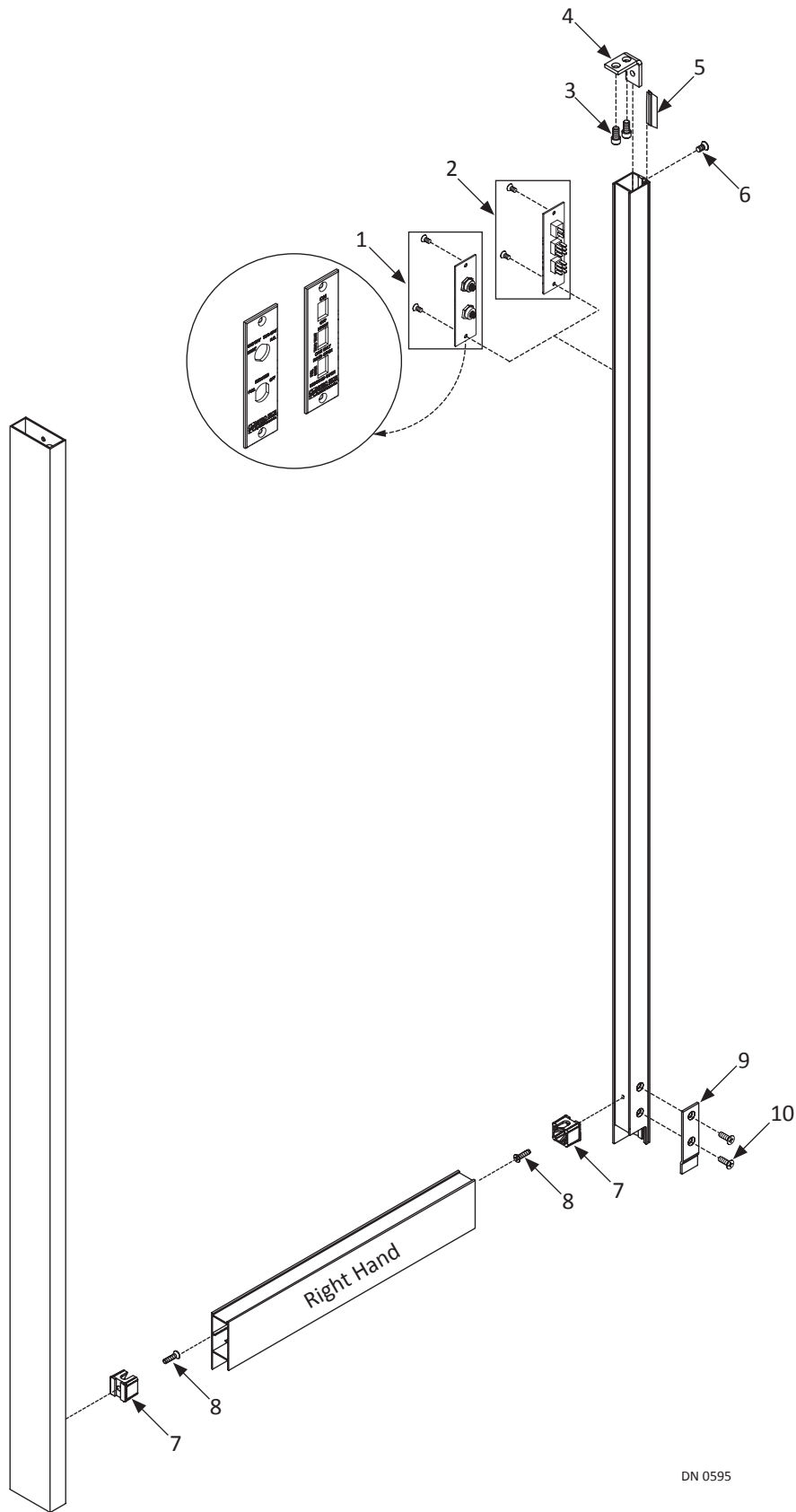

Wall Track			
Item	Part	Finish/Sizes/Notes	Description
1	M-01144		SWITCH, KEY - NABCO
	M-01145		SWITCH, KEY - PORTA SERVICE
2	M-00428		SWITCH MODULE,3 ROCKER,NABCO
	M-00429		SWITCH MODULE,3 ROCKER,PORTA
3	T-00053		SHCS,1/4-20x0.500L.,ZINC
4	M-00706		BRACKET,MOUNTING ,FIXED SIDELITE
5	M-01241	Gray/9/16"	WEATHERING, VINYL, 9/16IN GRAY FIN
	M-71241	Black/9/16"	WEATHERING,VINYL,9/16IN,BLK
	M-01239	Gray/1"	WEATHERING, VINYL, 1IN GRAY FIN
	M-71239	Black/1"	WEATHERING:VINYL:1.00:BLK
6	T-00055	Zinc	FHMS,1/4-20x0.500L.,PHIL,ZINC
	T-00057	Black Oxide	FHMS,1/4-20x0.500L.,PHIL,BLK ZN
7	M-00462		CLIP,MUNTIN,.261 HOLE
8	T-00061		FHMS,1/4-20x1.000L.,PHIL,TRI-LOBE,ZINC
9	M-00709	Zinc	COVER, PLATE, BOTTOM GUIDE, FS
10	T-00015	Zinc	FHMS,1/4-20x0.750L.,PHIL,ZINC

### SERVICE PARTS: SLIDE DOOR

Viewed from Break Out Side

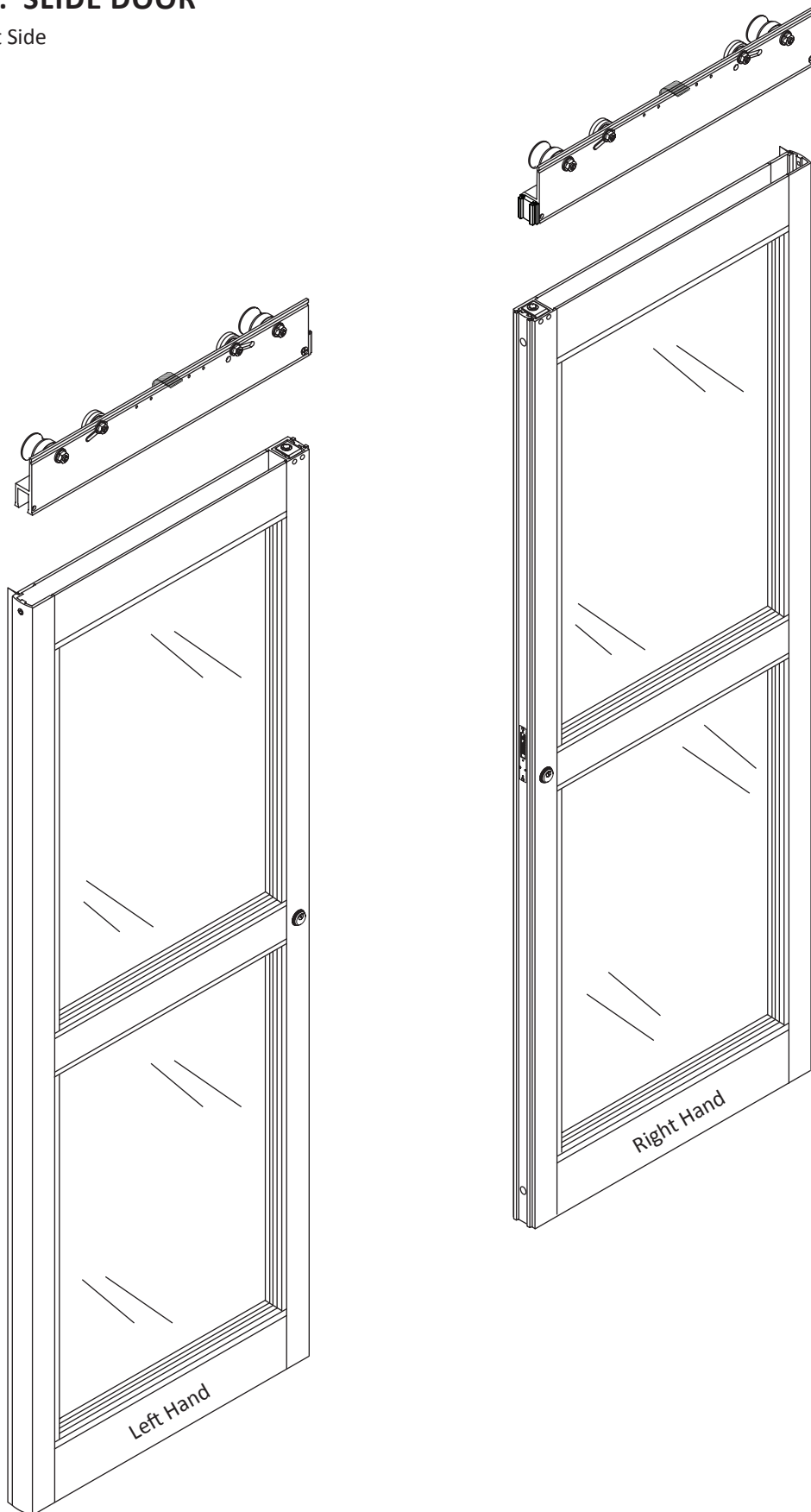

DN 0584

# SERVICE PARTS: LEFT HAND SLIDE DOOR

Viewed from Break Out Side

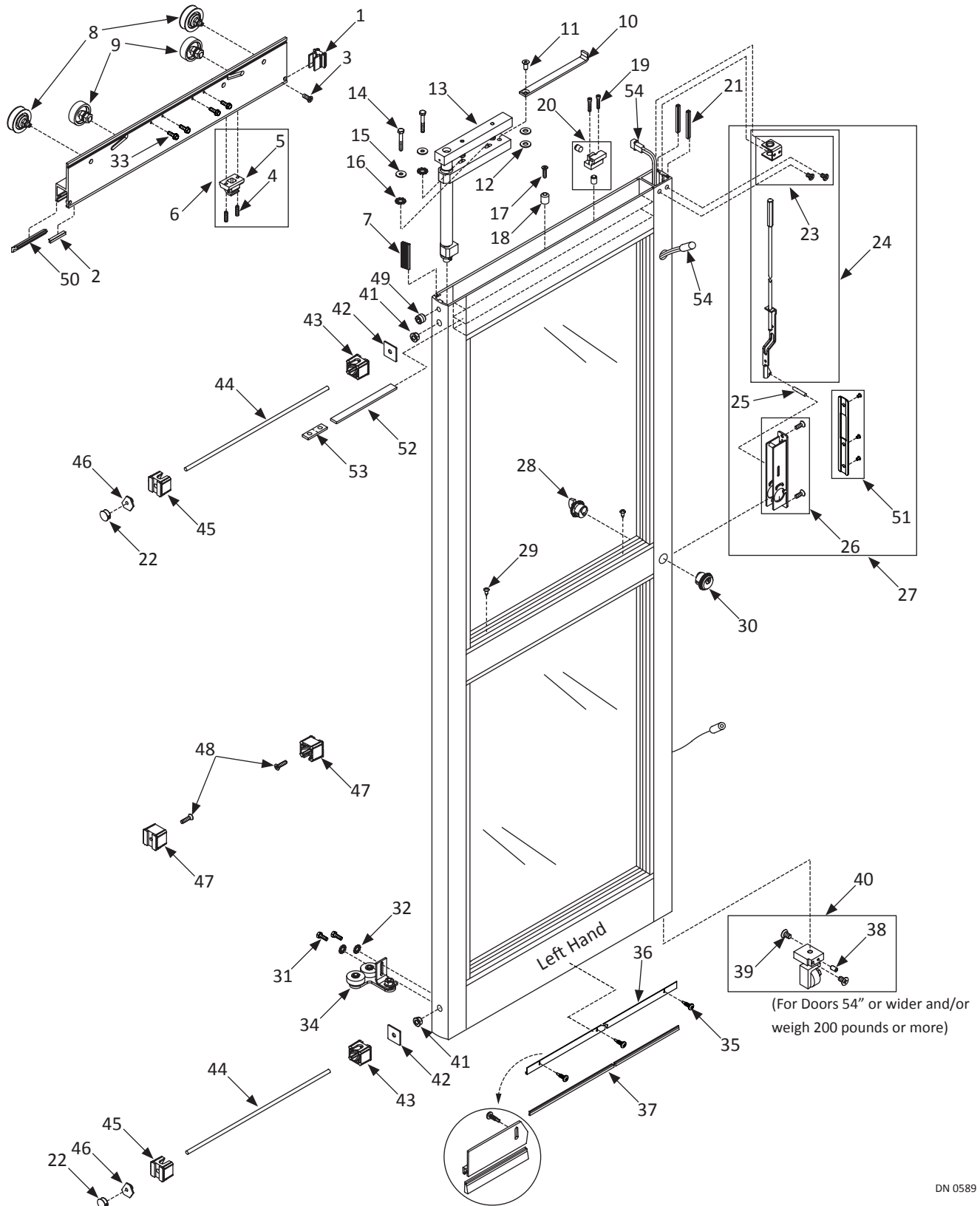

DN 0589

# SERVICE PARTS: RIGHT HAND SLIDE DOOR

Viewed from Break Out Side

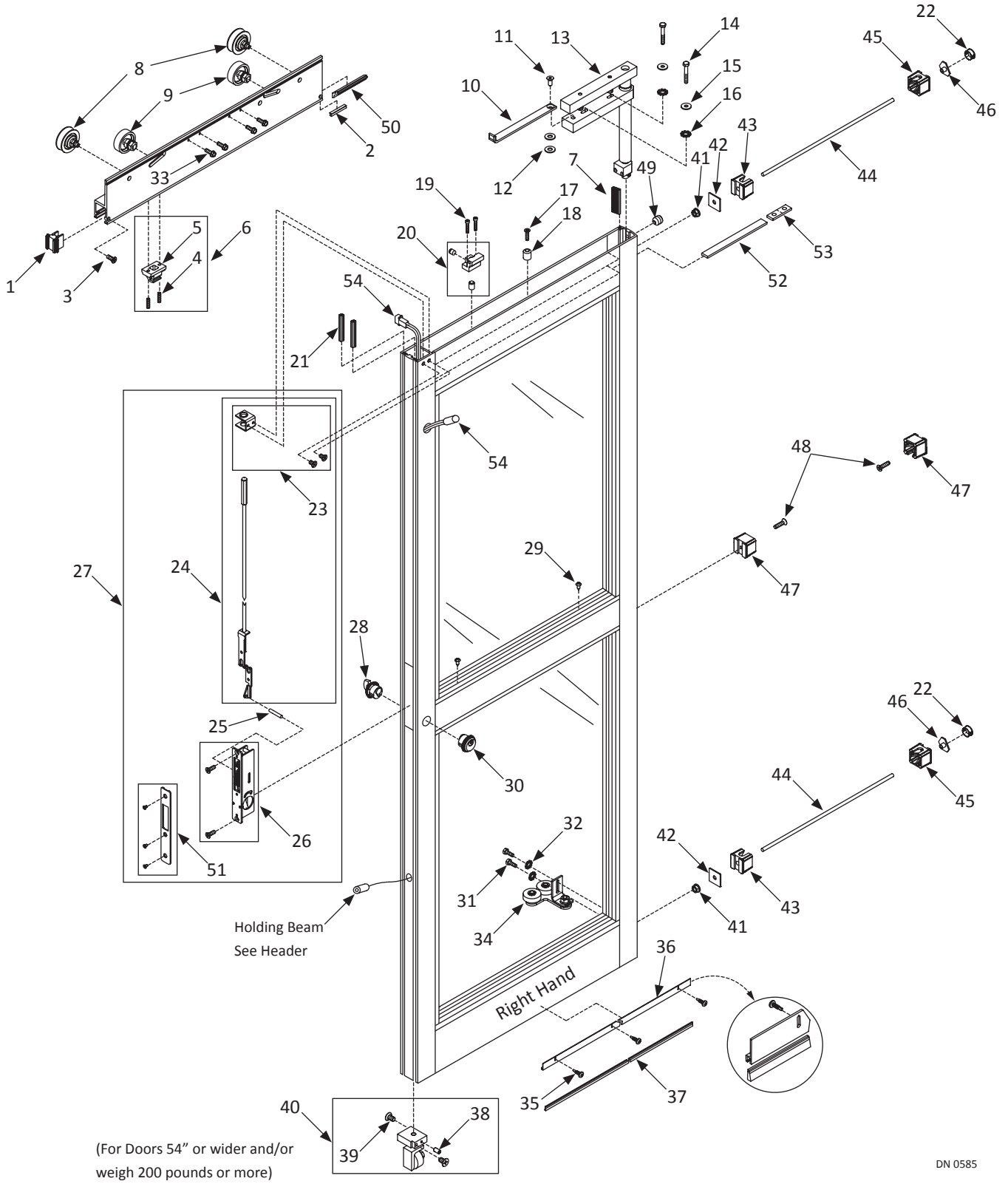

DN 0585

Slide Door			
Item	Part	Finish/Sizes/Notes	Description
1	A-60133	Clear	"CARRIER END CAP,204"
	A-70133	Dark Bronze	CARRIER END CAP,313
2	M-00690		WEATHER, PILE .2
3	T-00006		FHSMS,10x0.750L.,PHIL,ZINC
	T-00005		FHSMS,10x0.750L.,PHIL,BLK ZN
4	T-00091		SHSS,5/16-18x1.250L.,CUP PT.
5	M-00483		PANIC CATCH RELEASE ASSEMBLY
6	A-00071		PANIC CATCH, UPPER,ASM.
7	A-00951		"BRUSH, NYLON, .56 LX1.875L."
8	A-00162		ROLLER, HANGER, ASSEMBLY, 1175
9	A-00163		AXLE ASSEMBLY-ANTI RISE ROLLER
10	M-00379	Standard	LIMIT ARM, STANDARD STILES
	M-00704	Medium Stile	ARM, LIMIT, MEDIUM STILE
11	T-00018		FHCS,7/16-14x1.000L.,ZINC
12	T-00069		WASHER,.255 ID,.900 OD,.125 THK,NYLON
13	A-00092		CARRIER,PIVOT,NARROW STILE
	A-00165		CARRIER, PIVOT ASSY, MED STILE
	A-00168		CARRIER PIVOT ASM. NRW PANEL & STILE
	A-00172		CARRIER,PIVOT,ASM.,NRW.PNL - MED.STILE
14	T-00028		HHCS,1/4-20x1.750L.,GR5,ZINC
15	T-00029		WASHER,.250 ID,.563 OD,.049 THK,ZINC
16	T-00087		WASHER, LOCK, EXT, 1/4 ID, ZINC
17	T-00061		FHMS,1/4-20x1.000L.,PHIL,TRI-LOBE,ZINC
18	M-00653		BRACKET, LIMIT ARM SUPPORT
19	T-00037		SHCS,1/4-20x1.250L.,ZINC
20	A-00069		PANIC CATCH, BOTTOM
21	M-00688		PILE WEATHERING .45 TALL W/ ADHESIVE
22	V-00720		"PLUG,HOLE,13/16 DOME"""
23	M-01634		LOCK GUIDE (SUB COMPONENT OF LOCK ROD)
24	V-00094		LOCKROD, ADAMS-RITE #4015
25	T-00132		"PIN,ROLL,5/32D X 0.875L."
26	V-00005		LOCK, ADAMS-RITE #MS1853
27	A-00802		"LOCK,W/ ROD,CRL"
	A-00803		"LOCK,W/ ROD,ADAMS RITE"
28	V-00116	Clear	CYLINDER,LOCK,THUMBTURN,204
	V-70116	Dark Bronze	CYLINDER,LOCK,THUMBTURN,313
29	T-00098		PHSMS,10x0.563L.,PHIL,TYPE A
30	V-00123	Clear	CYLINDER,LOCK,KEYED,204
	V-70123	Dark Bronze	CYLINDER,LOCK,KEYED,313
31	T-00064		HHCS,1/4-20x0.750L.,ZINC
32	T-00087		WASHER, LOCK, EXT, 1/4 ID, ZINC



Slide Door			
Item	Part	Finish/Sizes/Notes	Description
33	T-00119		HHCS,1/4-20x0.750L.,WASH HD.TRILOBE,ZINC
34	A-00181	RH	BTM GUIDE DOUBLE ROLLER ASM, RH
	A-00183	LH	BTM GUIDE DOUBLE ROLLER ASM, LH
35	T-00222	Smoke Seal Only/Zinc	PHSMS,6x0.500L.,PHIL,TEKS,ZINC
	T-00260	Smoke Seal Only/Black Zinc	PHSMS,6x0.500L. PHIL,TEKS BLK ZN
36	M-60278	Clear	HOLDER,WEATHERING BRUSH,204,EXTRU
	M-70278	Dark Bronze	HOLDER,WEATHERING BRUSH,313,EXTRU
	M-90278	Bone White	HOLDER:WEATHERING BRUSH:BW:EXTRU
37	M-00274		BRUSH, NYLON, 1" STEPPED
	M-00698		BRUSH, NYLON, 1.5"
38	T-00105		SHSS,8-32x0.313L.,CUP PT.
39	T-00016	Zinc	FHMS,1/4-20x0.438L.,PHIL,UNDERCUT,ZINC
	T-00108	Black Oxide	FHMS,1/4-20x0.438L.,PHIL,UNDERCUT,BLK ZN
40	A-00198	.090 Narrow Stile	NOSE CASTER ASSY, NAR
	A-00207	.125 Medium Stile	NOSE CASTER ASSY, MED
41	T-00025	Zinc	NUT,WHIZLOCK,3/8-16,ZINC
42	M-00422		PLATE,TIE ROD
43	M-00461		CLIP,MUNTIN,.386 HOLE
44	M-00272		3/8-16 THREADED ROD
45	M-00460		CLIP,MUNTIN,.500 HOLE
46	M-00416		T-NUT, 3/8"-16, TIE ROD
47	M-00462		CLIP,MUNTIN,.261 HOLE
48	T-00061		FHMS,1/4-20x1.000L.,PHIL,TRI-LOBE,ZINC
49	T-00261		SHSS,5/16-24x0.500L.,CUP PT.
50	M-60288	Clear	INTERFACE LEG,204,EXTRU
	M-70288	Dark Bronze	INTERFACE LEG,313,EXTRU
51	V-00014	Clear	COVER,MS LOCK,W/ CUTOUT,204
	V-70014	Dark Bronze	COVER,MS LOCK,W/ CUTOUT,313
52	M-01189	Secures magnetic strip inside Rail	MAGNET, WEDGING STRIP
53	M-00282	Cut to full length of Top Door Rail Located inside Top Door Rail	FLEXIBLE MAGNETIC STRIP
54	A-00387	For Fixed Sidelite only	BREAK OUT SWITCH, WIDE GAP - F/S

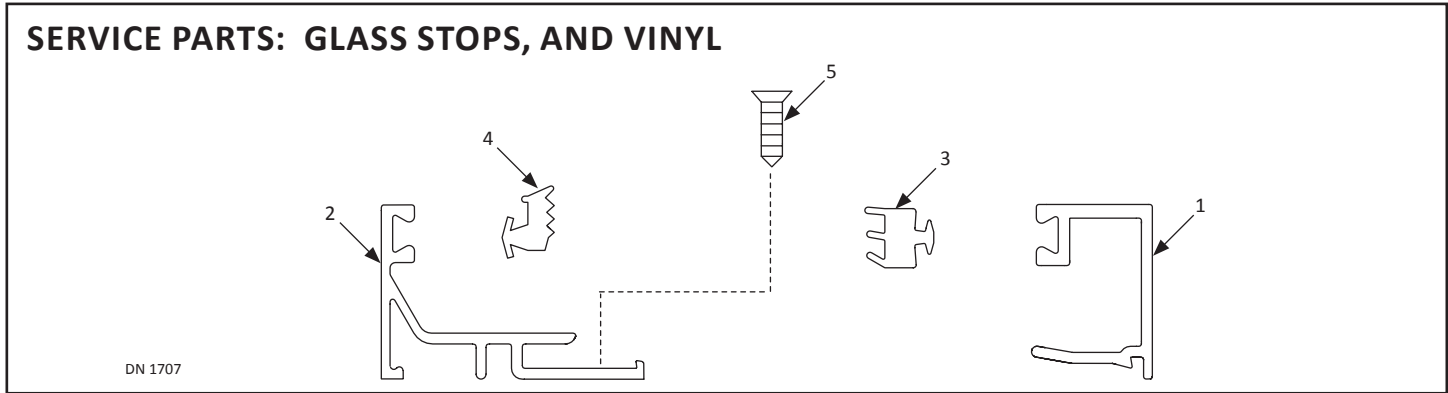

Glass Stops and Vinyl				
Item	Part	Finish/Sizes/Notes	Description	
1	M-60333	Clear	GLASS STOP,TOP, 1" TALL, 204 ,EXTRU	
	M-70333	Dark Bronze	GLASS STOP,TOP, 1" TALL, 313 ,EXTRU	
2	M-60266	Clear	GLASS STOP, SCREW DOWN, BASE,204,EXTRU	
	M-70266		GLASS STOP,SCREW DOWN,BASE,313,EXTRU	
3	M-00263		VINYL GLASS STOP THREE PRONG	
4	M-00284		VINYL GLASS STOP TEAR DROP	
5	T-00137		"FHSMS,8x0.625L.,PHIL,TYPE A"	