



GT2150 Full Open w/Track Manual Slide Door
Quick Set-Up Parts Guide
P/N C-00101 Rev 8-18-16

Nabco Entrances Inc. S82 W18717 Gemini Drive Muskego, Wisconsin 53150
Phone: (877) 622-2694 Fax: (888) 679-3319 www.nabcoentrances.com

Associated Manuals Part Numbers: GT 2150 Manual Slider Installation Manual (P/N 15-12941)
Manual Slide Door Owner’s Manual (P/N C-00189) for Decal Installation
NABCO Price Book” for Sensors, Switches, and Accessories (P/N 16-9244-30)

Table of Contents

SECTION 1: INSTALL FRAME 2

SECTION 2: POSITION THE FLOOR TRACK 2

SECTION 3: INSTALL THE SWING SIDELITE 2

SECTION 4: ADJUST THE BALL DETENTS 4

SECTION 5: INSTALL THE SLIDE DOOR 4

SECTION 6: SECURE THE FLOOR TRACK..... 5

SECTION 7: ADJUSTMENTS..... 5

SERVICE PARTS: HEADER 7

SERVICE PARTS: FULL OPEN SIDELITE 9

SERVICE PARTS: RIGHT HAND FULL OPEN SIDELITE 10

SERVICE PARTS: LEFT HAND FULL OPEN SIDELITE..... 11

SERVICE PARTS: SLIDE DOOR 13

SERVICE PARTS: RIGHT HAND SLIDE DOOR 14

SERVICE PARTS: LEFT HAND SLIDE DOOR..... 15

SECTION 1: Install Frame

1. Go to the non-breakout side of rough opening. Place Header on a flat surface with the removable cover facing up.
2. Refer to the instruction sticker located on each Jamb Tube to properly orientate Jamb Tubes.
3. Remove Cover from Header. Remove Parts boxes and/or Parts bags from inside Header. Set aside.
4. Secure Frame to Rough Opening with 1/4 inch diameter anchors or 3/8 inch threaded rods, with a maximum 48 inches on center for the Header and Jamb Tubes (First anchor maximum is 36 inches from each end of the Header).

SECTION 2: Position the Floor Track

Note: Do Not Secure Floor Track until both the Sidelite and Slide Door have been installed. Failure to do so may cause misalignment.

1. Obtain Floor Track that was cut to specification at the NABCO Factory.
2. If not installed, obtain Filler Inserts and Threshold Bumpers that were provided by NABCO (cut to specifications).

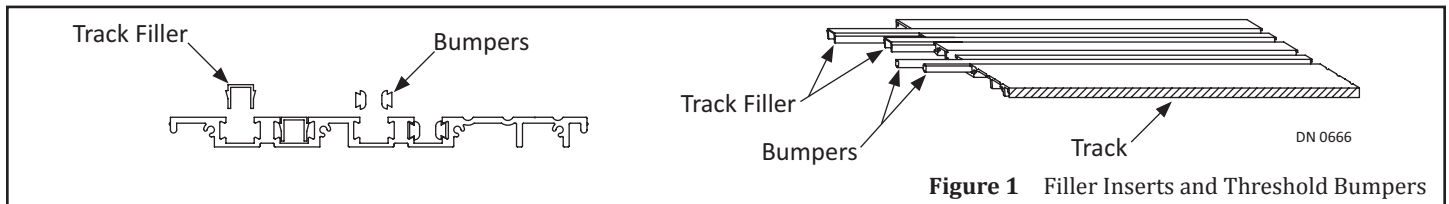

Figure 1 Filler Inserts and Threshold Bumpers

3. Install Filler Inserts within areas that has a door opening. Please see Figure 2.
4. Install Threshold Bumpers within areas that does not have a door opening.

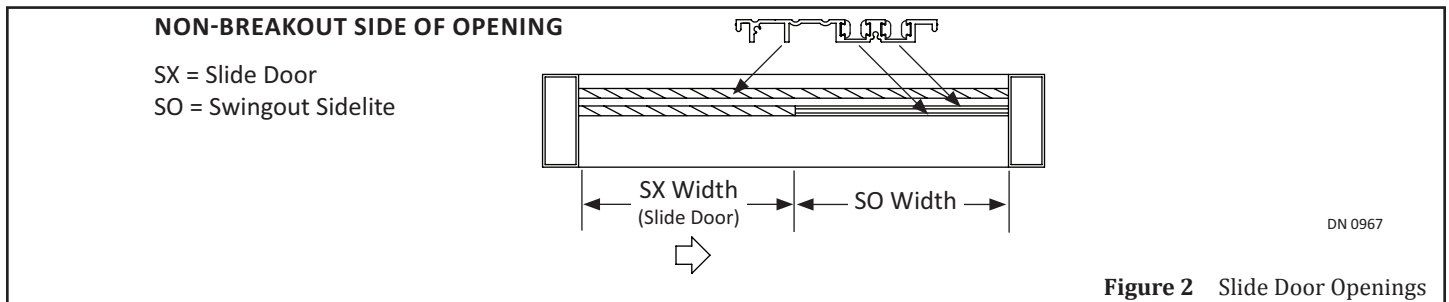

Figure 2 Slide Door Openings

5. On the **Non-Breakout side of opening**, snap a chalk line on the floor from Jamb to Jamb.
6. Position the Floor Track between Jamb tubes until the full length is flush with the chalk line.
 - a. The Floor Track (not including the Ramps) is the same width as the Jamb Tube for both types of Units.

2.1 Recessed Floor Track (Only)

1. Remove the Floor Track. Set aside.
2. Create a channel that is 1/2 inch deep x full width of Jamb Tube x full length of the Floor Track.
 - a. Full length of Floor Track and width of Jamb Tube will vary according to specifications.

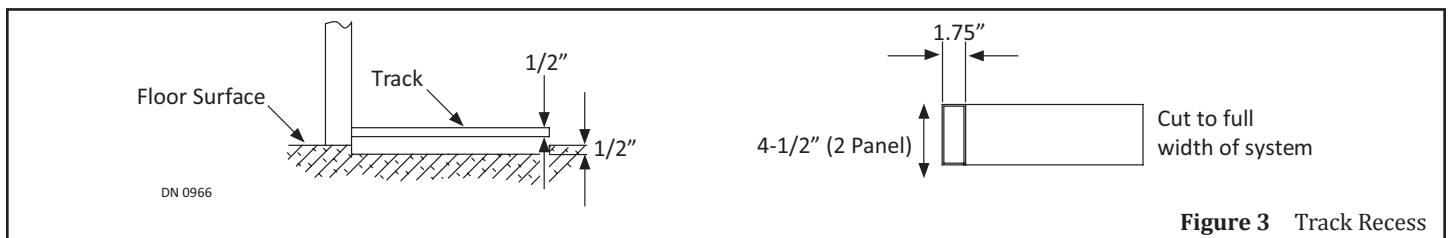
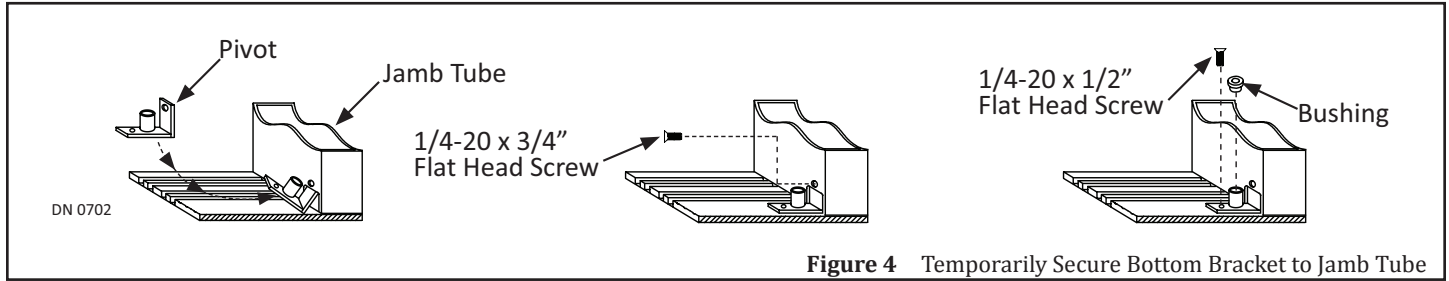

Figure 3 Track Recess

SECTION 3: Install the Swing Sidelite

1. Obtain the Bottom Pivot assembly provided by NABCO.
2. Insert the Bottom Pivot into a Notch located at the bottom of Jamb tube.
3. Secure Bottom Pivot to Jamb tube with (1) 1/4-20 x 3/4 inch Self Tapping screw.
4. Secure the Bottom Pivot to the Floor with (1) 1/4-20 x 1/2 inch Phillips Screw.
5. Cap the barrel of Pivot with a Bushing provided by NABCO.



6. Obtain (1) Limit Arm Assembly provided by NABCO.
7. Slide (1) Spacer onto the Red Coated 1/4-20 x 1 Flat Head screw. Insert the Red Coated 1/4-20 x 1 Flat Head screw through the Limit Arm screw hole.
8. Slide (1) small Washer and (1 - 2) large Washers (as required) on top of the Red Coated Screw.
9. Secure the Limit Arm to the bottom lip of Header Cover by inserting the Screw assembly into the Factory Drilled Hole.
10. Tighten the Red Coated Screw so the Limit Arm Assembly does not fall out of hole. Do not fully tighten screw at this time.

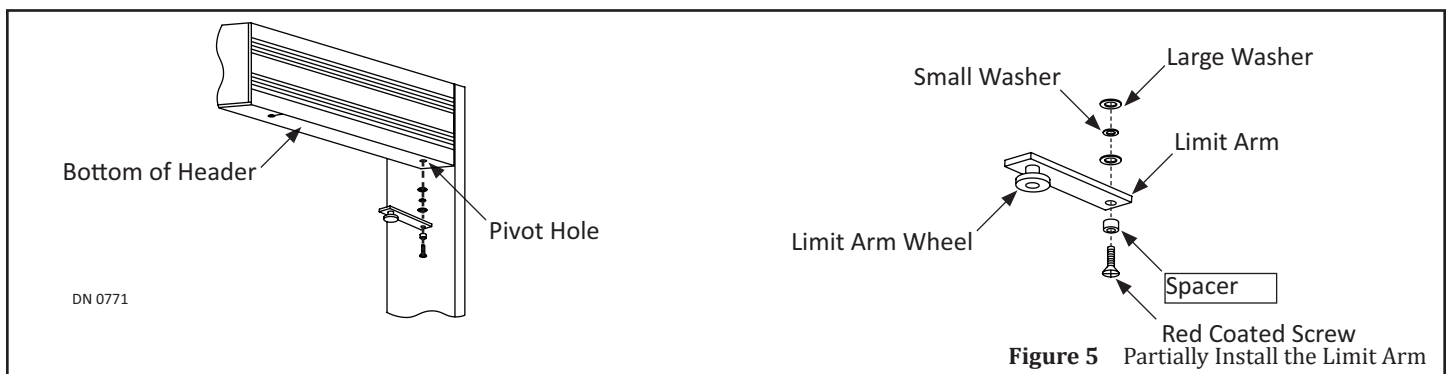

11. Carefully position the Swing Sidelite Panel over the Bottom Pivot. Ensure the Breakout side of the Swing Sidelite Panel is on the breakout side of the opening.

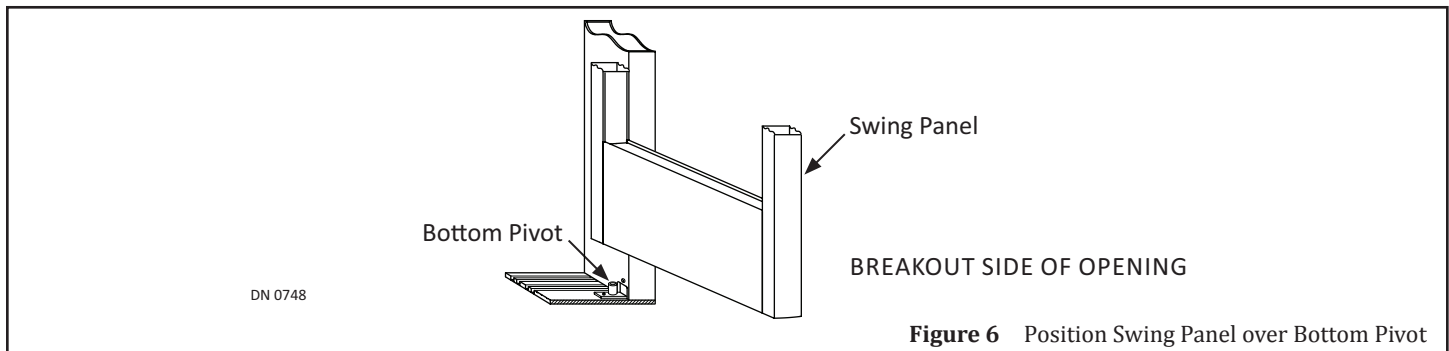

12. Go to the Retracting Pin located inside the Pivot Stile at the very top.
13. Push the Retracting Pin down. At the same time, align the Pivot Pin with the Top Pivot Bracket hole located on bottom of Header. Allow the Pivot Pin to snap into the hole located on the Top Pivot Bracket.
 - a. Ensure Pivot Pin fully engages the hole. If necessary, lift up on the retracting pin with a screwdriver.

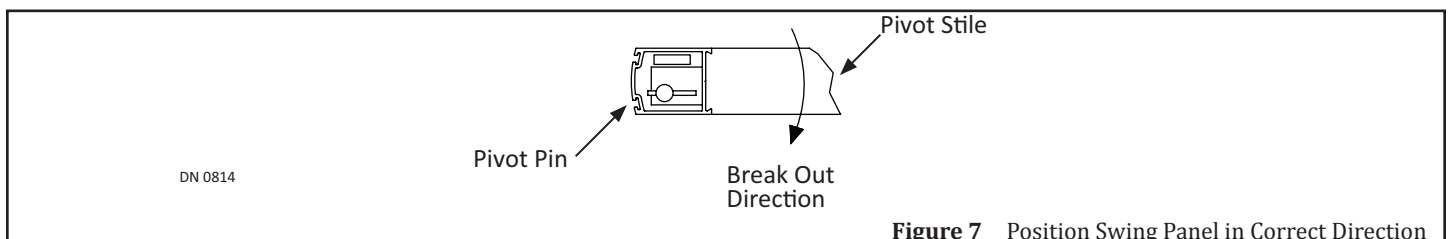

14. Open the Swing Sidelite Panel out to 90 degrees. Align the Limit Arm with the Top Rail.
15. Rest the Wheel of the Limit Arm inside the Top Rail.

16. Open the Swing Sidelite Panel all the way.
17. Tighten the Red Coated 1/4-20 x 1 Flat Head screw. Do not overtighten.
18. Test the Swing Sidelite Panel to ensure it opens and closes properly. Tighten and/or untighten Red Coated 1/4-20 x 1 Flat Head screw as deemed necessary.

SECTION 4: Adjust the Ball Detents

Note: Breakout resistance for Ball Detents must meet ANSI Standard A156.10 or Local Codes.

1. With a 15/16" Open End wrench, loosen the Nut to raise or lower the Ball Detent at Top of Strike Stile so it has light contact with the Bottom of Header.
2. Open and close the Swing Door several times to score the surface on the Bottom of Header. Locate and mark where the Score intersects the center groove.
3. With a 1/4 inch diameter drill bit, drill a screw hole through the Bottom of Header. Countersink the screw hole to be 3/8 inch x 82°.

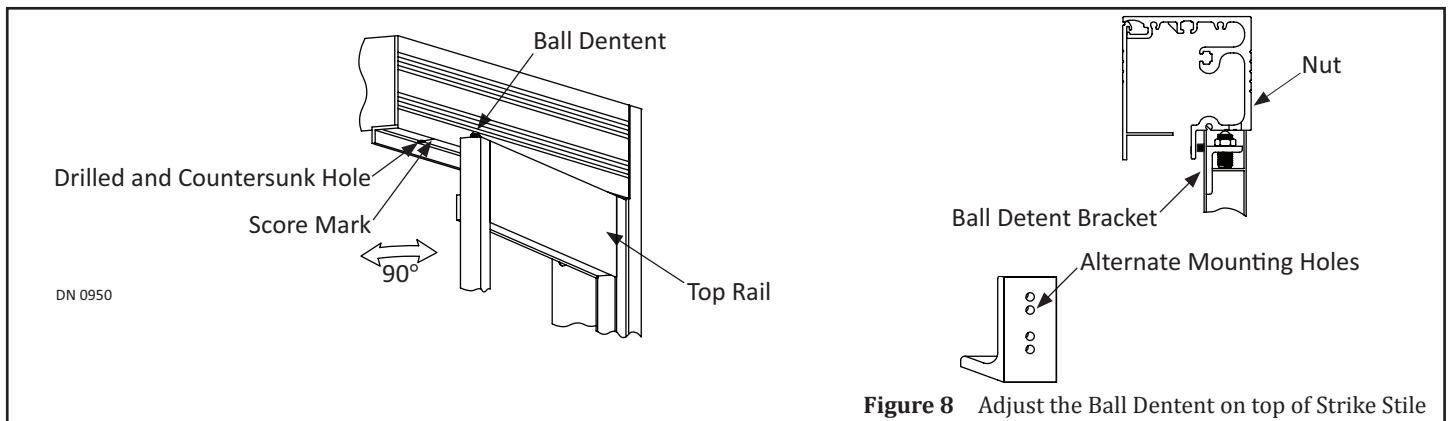

4. With a 15/16" Open End wrench, loosen the Nut to raise or lower the Ball Detent at Bottom of Strike Stile so it has light contact with the Floor Track.
5. Open and close the Swing Door several times to score the surface on the Floor Track.
6. Locate and mark where the Score intersects the center groove.
7. With a 1/4 inch diameter drill bit, drill a hole through the Floor Track (Just deep enough for the Ball Detent to fit within). Countersink the screw hole to be 1/4 inch x 82°.

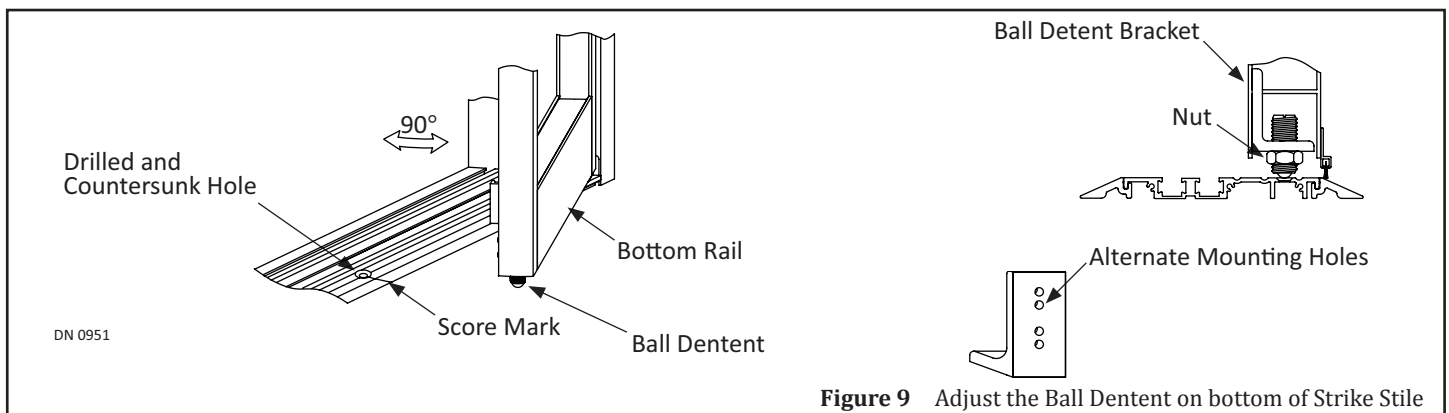

8. Close and then break open the Swing door to test fit both Ball Detents.
 - a. Increase hole size and countersink size until a satisfactory fit is obtained.
 - b. Do Not over-drill the hole. If hole is overdrilled the Floor Track will need to be replaced.
 - c. For additional travel remove the ball Detent Bracket to lower or raise the Ball Detent.

SECTION 5: Install the Slide Door

1. Cover the Sidelite Panel with cardboard on the non-breakout side.
2. Remove each Roller located at the front of Carrier. Refer to the instruction sticker to reinstall each Roller to the back of Carrier. Ensure each Roller is horizontally aligned to each other. Please see Figure 10.

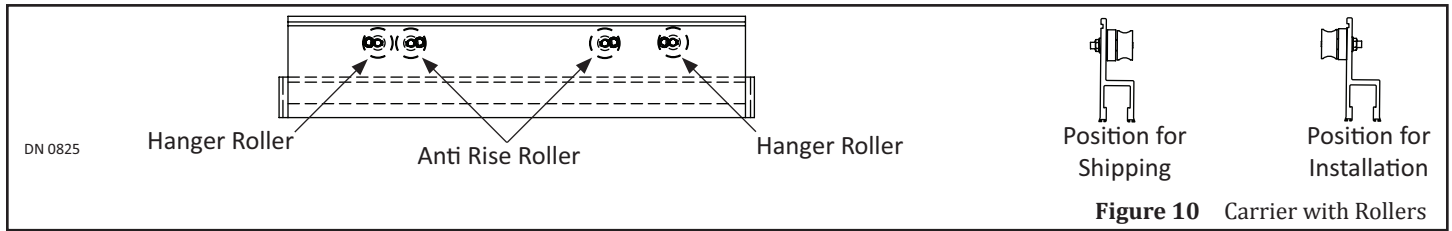

Figure 10 Carrier with Rollers

3. Slightly tilt the Slide door to make it easier for the (4) Rollers to 'catch' onto the track.
4. Pry up on the pre-installed Full Open Bottom Guide so the prongs can enter the Floor Track in the appropriate slots.

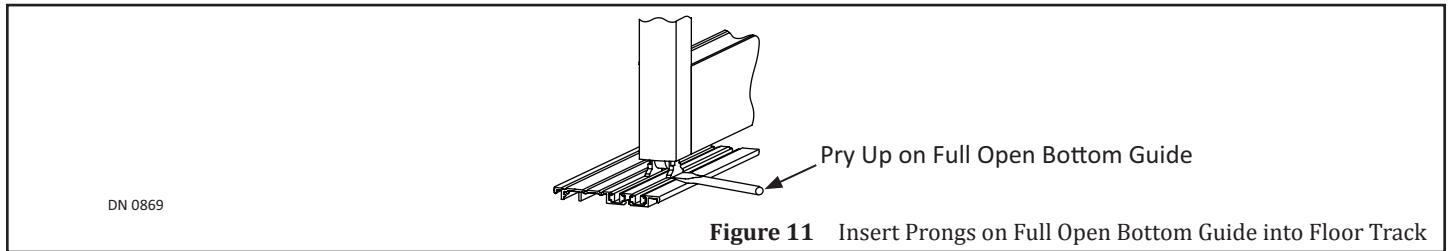

Figure 11 Insert Prongs on Full Open Bottom Guide into Floor Track

5. Adjust the Slide Door in Section "7 Adjustments".

SECTION 6: Secure the Floor Track

1. Obtain #10 x 1-1/2 inch sheet metal screws and #6 Green Anchors provided by NABCO.
 - a. The number of provided screws and anchors depends upon length of Floor Track.
2. Go to a metal strip that is used to divide the Filler Inserts.
3. Go to each end of Floor Track. Mark (1) drill hole approximately 4" from each edge.
4. With a 1/4 inch masonry drill bit, drill through the Floor Track and into the floor no less than 1-1/2 inch deep.
5. Insert plastic anchors into the drilled holes.
6. Secure the Floor Track with #10 x 1-1/2 inch sheet metal screws.

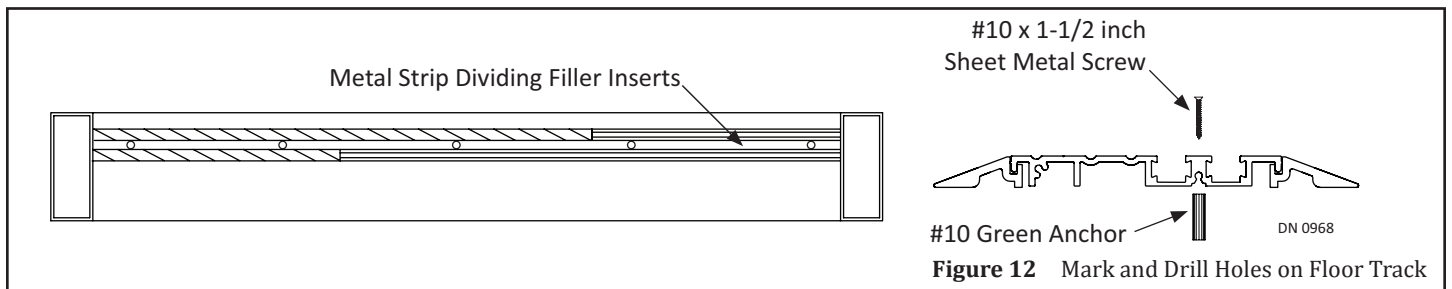

Figure 12 Mark and Drill Holes on Floor Track

SECTION 7: Adjustments

7.1 Adjust Height on Slide Door

CAUTION Do Not rotate the stud counter-clockwise. Doing so will unthread the Axle from the Hanger Roller assembly.

1. Measure the gap between the door and the floor. The gap must be between 3/16" to 7/16" (3/8" nominal).
2. Loosen each Hanger Roller Nut. It is recommended to adjust the (2) Hanger Rollers located at each end of door first.
3. Turn each axle clockwise to raise or lower the Sliding door. Retighten each Hanger Roller nut. Do not overtighten.
4. Loosen each Anti-Rise Roller nut. Turn each axle clockwise until each Anti-Rise Roller almost makes contact with the top of Roller Track. Gap should be about the same thickness of a credit card. Retighten each Anti-Rise Roller nut. Do not overtighten.

7.2 Adjust Preload on Slide Door

CAUTION Glass must be installed first before adjusting Preload on Slide Door.

CAUTION When a Preload Block is shifted, it will be necessary to gently tap on one end of the Interface Leg (located inside the Carrier) until it is properly recentered.

1. Support the weight of sliding door. Breakout sliding door approximately 75 degrees. Check for door sag.
2. Go to the Preload Block located inside the Top Rail. Loosen (2) Locking Bolts.
3. Go to the back edge of Pivot Stile. Reduce door sag by tightening the 5/16 inch Adjustment Set Screw with a 5/32 inch Allen Wrench.
 - a. The door should lift without having to be manually lifted.
 - b. Do not allow the Adjusting Set Screw to protrude more than 5/32 inch past the end of stile.
 - c. If an optional 1/2 inch Adjustment Set Screw provided by NABCO is deemed necessary, it could mean the Preload is misaligned. Go to Section 7.3 before replacing the 5/32 inch Adjustment screw.

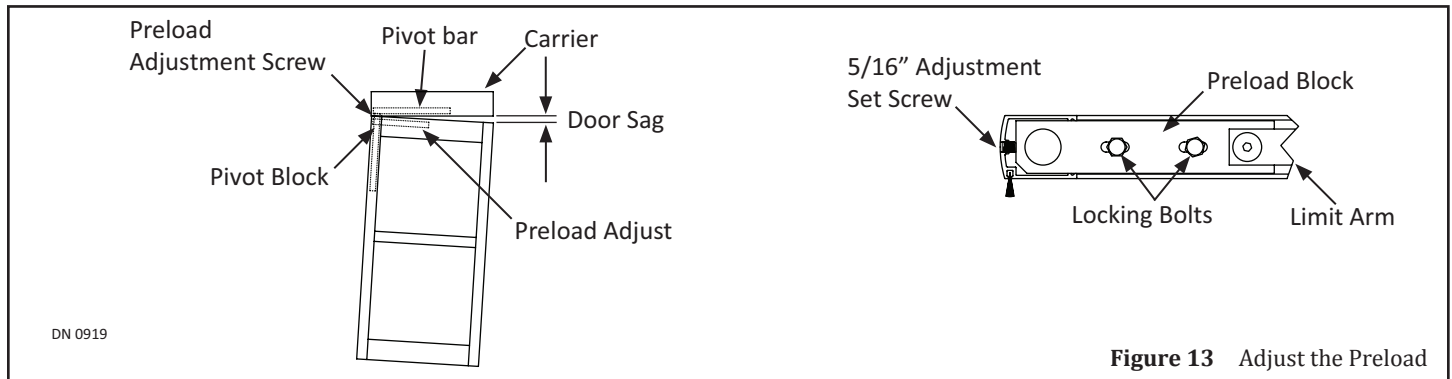

Figure 13 Adjust the Preload

7.3 Correct Preload Misalignment

1. Check to see if misalignment exists on the Strike end of the Door and Carrier.
2. Loosen the Allen head fasteners on the Pivot bar that is located inside the Carrier. Slide the Pivot bar until the door and Carrier are properly aligned.
3. Verify that the Panic Catch inside the Top Rail and the Carrier are still aligned. If not, loosen the 5/16 inch set screw to align the Carrier Panic Catch with the Top Rail Panic Catch.

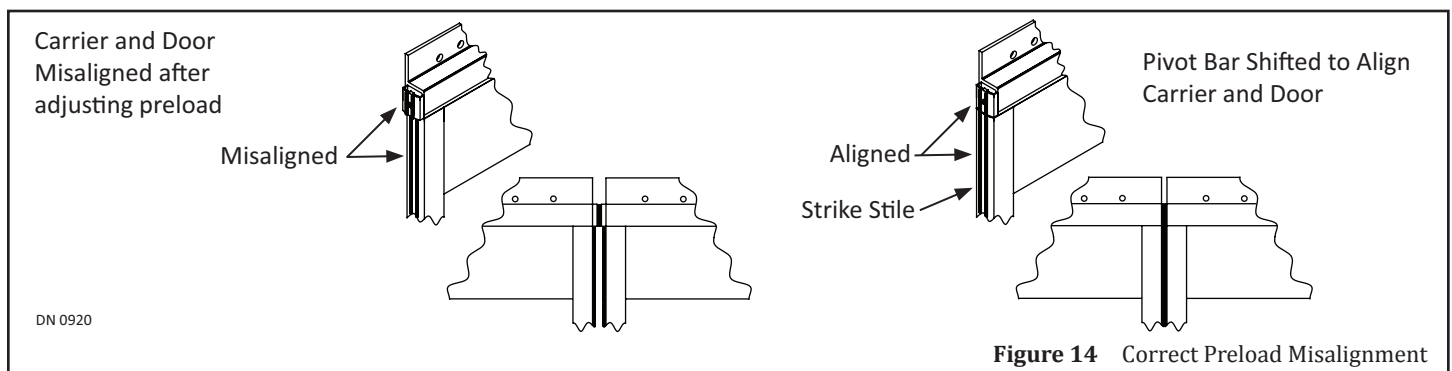

Figure 14 Correct Preload Misalignment

7.4 Adjust the Nose Caster

Note: Nose Casters are pre-installed for Sliding Doors that are 54 inches Wide (or greater) and/or over 200 pounds.

1. Loosen the #8-32 Set Screw. Position the Wheel so it is perpendicular to the Bottom Rail.
2. Retighten the #8-32 Set Screw.
3. Break open the Slide door. Ensure the Slide door does not scrape the floor. If it does lower the Nose Caster further.

SERVICE PARTS: HEADER

Viewed from *Break Out Side*

* Sold in Parts Bag; P/N 21-9251

** Sold in Parts Bag; P/N 12-11019

*** Bi-Part Feature Only

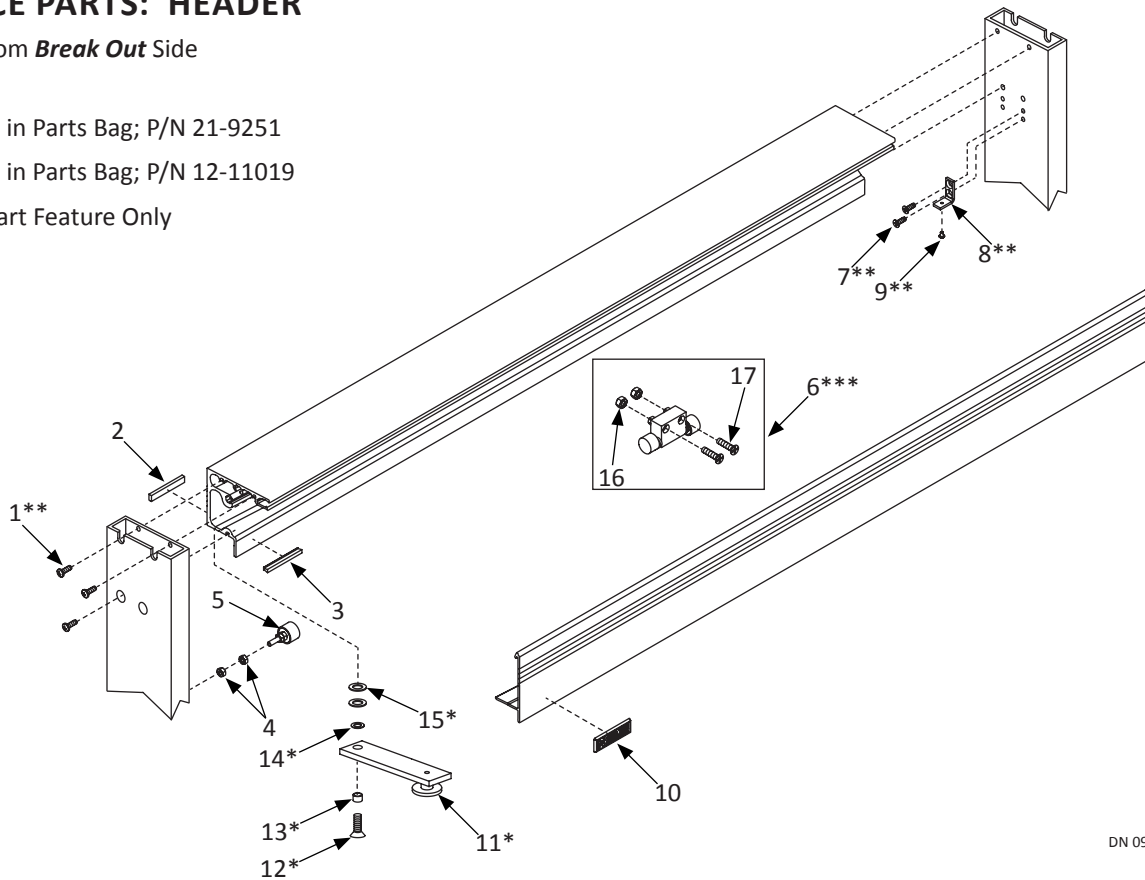

DN 0954

Header				
Item	Part	Finish/Sizes/Notes	Description	
1	24-0015-61	Zinc	RHMS,1/4-20 X 3/4" PHIL, TYPE F, ZN	
2	14-8161-01	Smoke Seal only	TAPE, .25 X .50 FOAM	
3	14-2279-05	Smoke Seal only/Black	PILE WEATHERING, BLK, .45 TALL, W/ ADHES	
4	24-0021-14	Zinc	HEX NUT, 1/4-20, ZN	
5	12-8233		DOOR STOP ASSY JAMB MOUNTD-SPECIAL	
6	12-11107		DOOR STOP ASSEMBLY CENTER -BIPART	
7	24-0011-70	Zinc	FHMS, 1/4-20 X 7/16", PHIL, UND, ZN	
8	14-10727		CLIP, COVER	
9	24-0015-22	Zinc	RHMS,#8-32 X 1/4", PHIL, ZN	
10	14-9199		NAMEPLATE, ADHESIVE BACKED	
11	21-8160		LIMIT ARM ASSY, SWING PANEL	
12	22-3590-06		SCREW - PHILLPS FL HD W/VIBR 1/4-20 X 1	
13	14-8658		SPACER, LIMIT ARM	
14	24-0017-04		WASHER, 1/4 ID X 9/16 OD X .049 THK, STL	
15	24-0017-14		WASHER, 5/16 ID X 3/4 OD X .062 THK	
16	24-0021-14		HEX NUT, 1/4-20, ZN	
17	24-0011-19		FHMS,10-24 X 3/4", PHIL, BLK ZN	

SERVICE PARTS: FULL OPEN SIDELITE

Viewed from *Non-Break Out* Side

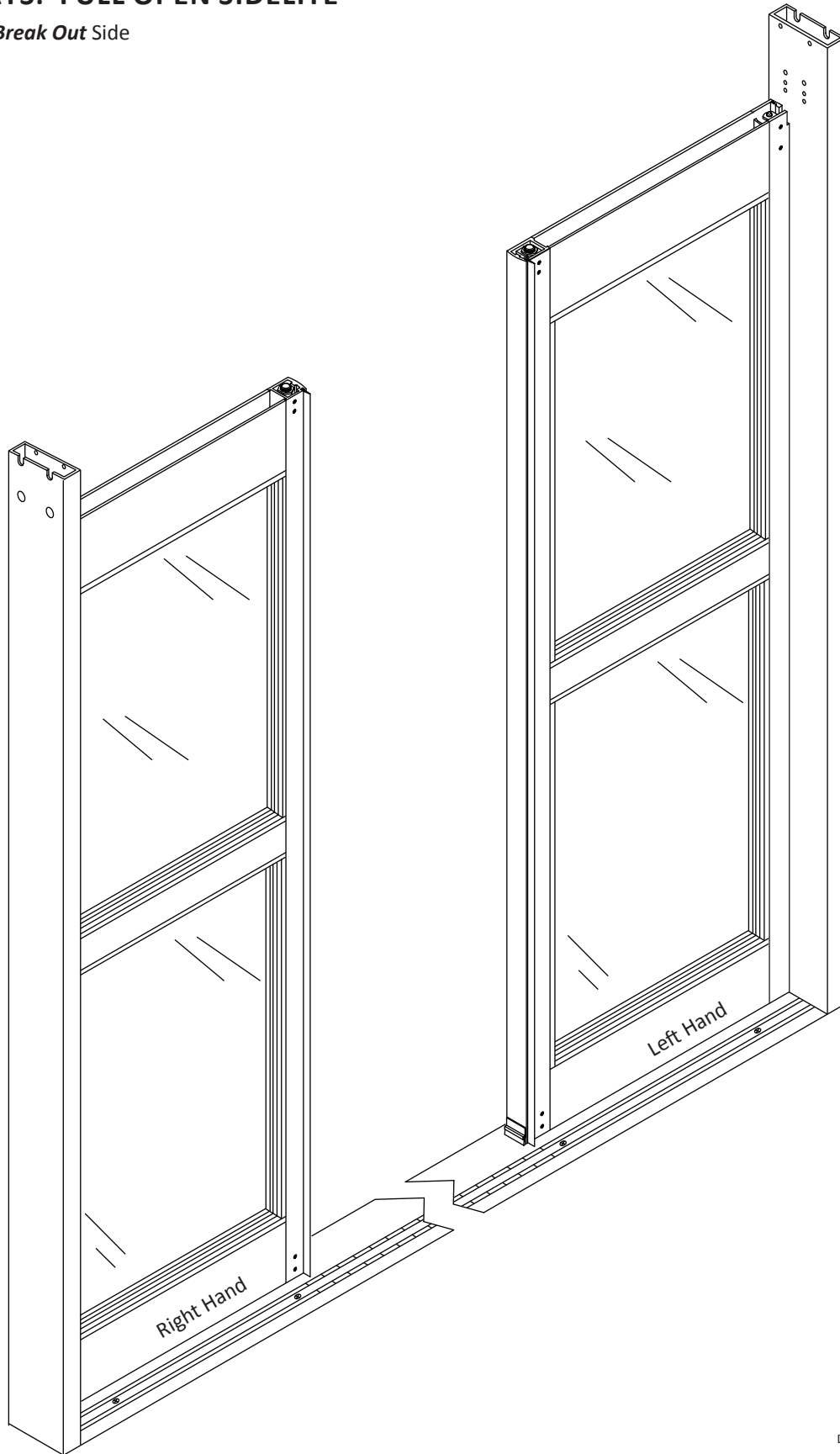

DN 0943

SERVICE PARTS: RIGHT HAND FULL OPEN SIDELITE

Viewed from *Non-Break Out* Side

* Sold in Parts Bag; P/N 21-9251

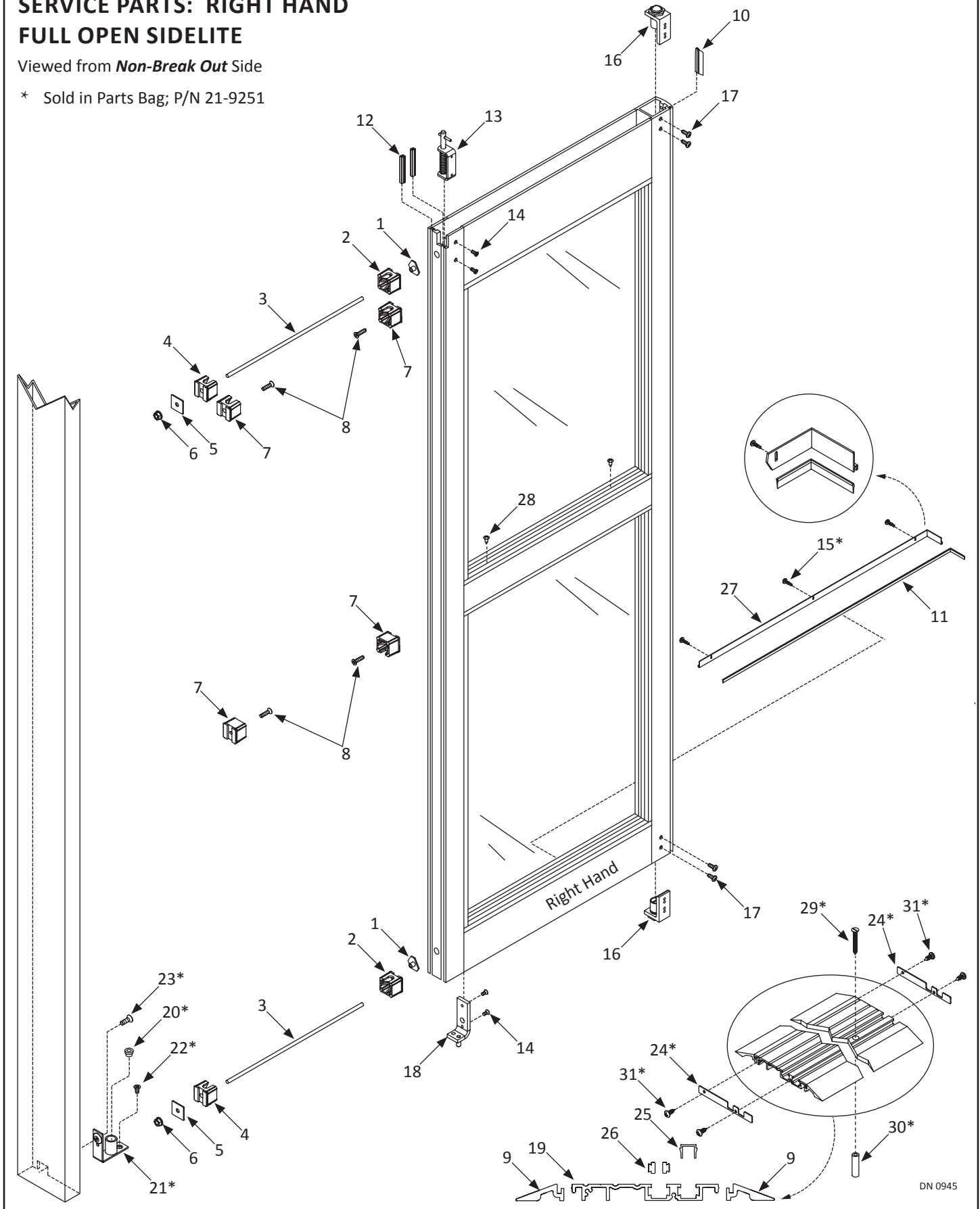

DN 0945

SERVICE PARTS: LEFT HAND FULL OPEN SIDELITE

Viewed from *Non-Break Out Side*

* Sold in Parts Bag; P/N 21-9251

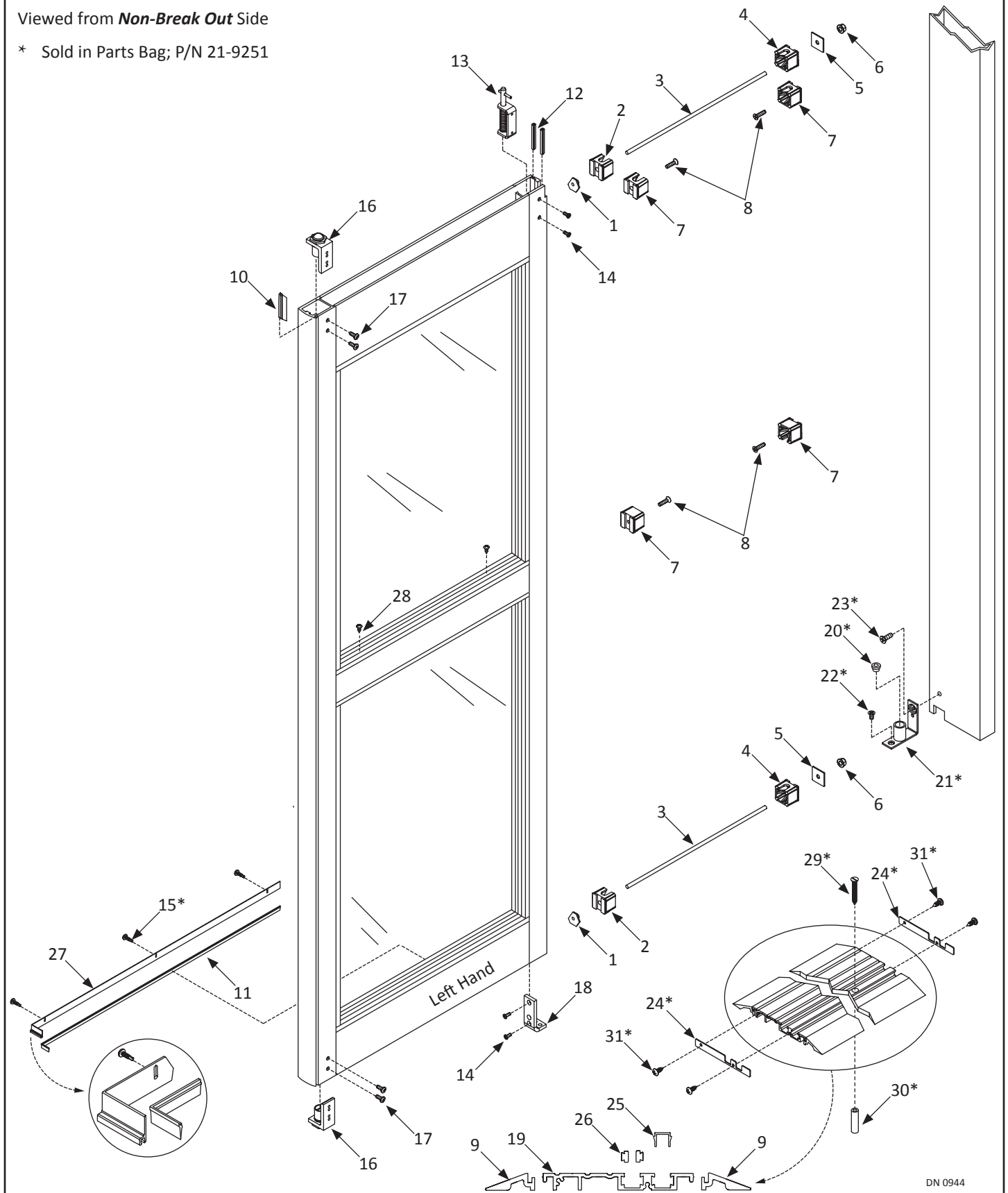

Full Open Sidelite			
Item	Part	Finish/Sizes/Notes	Description
1	14-9279		OFFSET TEE NUT, 3/8"-16
2	24-9503		CLIP, MUNTIN BAR - RAIL .500 HOLE
3	14-3624	Zinc	THREADED ROD, 3/8"-16 - ZINC PLATED
4	24-9504		CLIP, MUNTIN BAR - RAIL .386 HOLE
5	14-9225		BACKING PLATE, TIE ROD - DOOR ASSEMBLY
6	24-0021-21	Zinc	NUT, WHIZLOCK, 3/8-16, ZN
7	24-9502		CLIP, MUNTIN BAR - RAIL .261 HOLE
8	24-4941-02	Zinc	FHMS, 1/4-20 X 1", PHIL, TRILOBE, ZN
9	14-9017-01		EXTRUSION, ALUM - RAMP, FLOORTRACK
10	14-5592-01	Smoke Seal Only/Gray	WEATHER STRIP - 9/16 IN VINYL FIN, GRAY
	14-5592-02	Smoke Seal Only/Black	WEATHER STRIP - 9/16 IN VINYL FIN, BLACK
11	14-3933-01	Smoke Seal Only/1 inch/Gray	WEATHERING GRAY VINYL 1 IN FIN
	14-3933-02	Smoke Seal Only/1 inch/Black	WEATHERING BLACK VINYL 1 IN FIN
12	14-8632	Black	WEATHERING TRI POLY BLACK BULB
13	21-9507		ASM, TOP PIVOT, 1175 SWING PANEL
14	24-0011-105		FHMS, 10-32 X 1/2", PHIL, UND, ZN
15	24-0013-03	Smoke Seal Only/Zinc	PHSMS, 6 X 1/2", PHIL, TEKS, ZN
	24-0013-04	Smoke Seal Only/Black Zinc	PHSMS, 6 X 1/2", PHIL, TEKS, BLK ZN
16	12-9082		BALL DETENT PANIC, SWING PANEL
17	24-0012-14		PHMS, #10-32 X .50 LG, PHL, ZINC
18	11-9509-01	LH	BOTTOM PIVOT SWING PANEL ASSY - LH
	11-9509-02	RH	BOTTOM PIVOT SWING PANEL ASSY - RH
19	14-9016-01		EXTRUSION, ALUM - THRESHOLD, FLOOR TRACK
20	24-2458		BOTTOM PIVOT BUSHING, SWING PANEL
21	22-4750		FLOOR PIVOT SUB-ASSY - GT1100 & 1175
22	24-4941-01		FHMS, 1/4-20 X 1/2", TYP F, UND, PHL, ZN
23	24-0011-13		FHMS, 1/4-20 X 3/4", PHIL, ZN
24	24-9857-10		END CAP, THRESHOLD - NORMAL FULL OPEN
25	14-9168		EXTRUSION, RPVC - FILLER, TRACK
26	14-9019		BUMPER, THRESHOLD
27	14-10659-01	Smoke Seal Only/LH/Clear	WEATHERING HOLDER
	14-10659-02	Smoke Seal Only/LH/Dark Bronze	WEATHERING HOLDER
	14-10660-01	Smoke Seal Only/RH/Clear	WEATHERING HOLDER
	14-10660-02	Smoke Seal Only/RH/Dark Bronze	WEATHERING HOLDER
28	24-0031-23		FHSMS, 10 X 3/4", TYPE A, PHIL, ZN
29	24-0031-17		FHSMS, 8 X 1 1/2", TYPE A, PHIL
30	14-6394		ANCHOR, STRT PLSTC 10-12" X 1"
31	24-0094-12		PHSMS, 6 X 3/8", TYPE AB, PHIL

SERVICE PARTS: SLIDE DOOR

Viewed from *Non-Break Out* Side

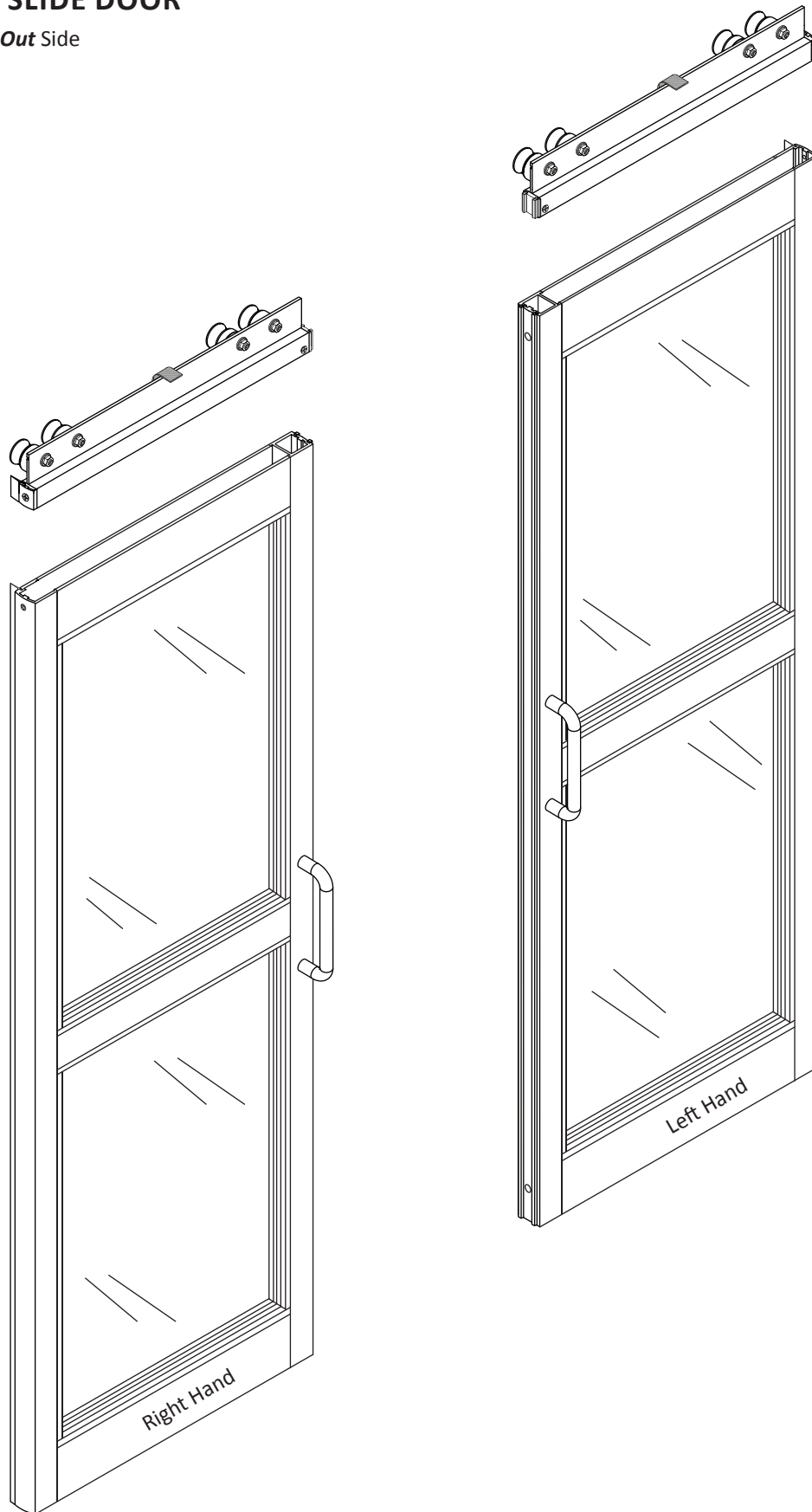

DN 0924

SERVICE PARTS: RIGHT HAND SLIDE DOOR

Viewed from *Non-Break Out* Side

* Sold in Parts Bag; P/N 21-9251

** For Doors 54" or wider and/or weigh 200 pounds or more

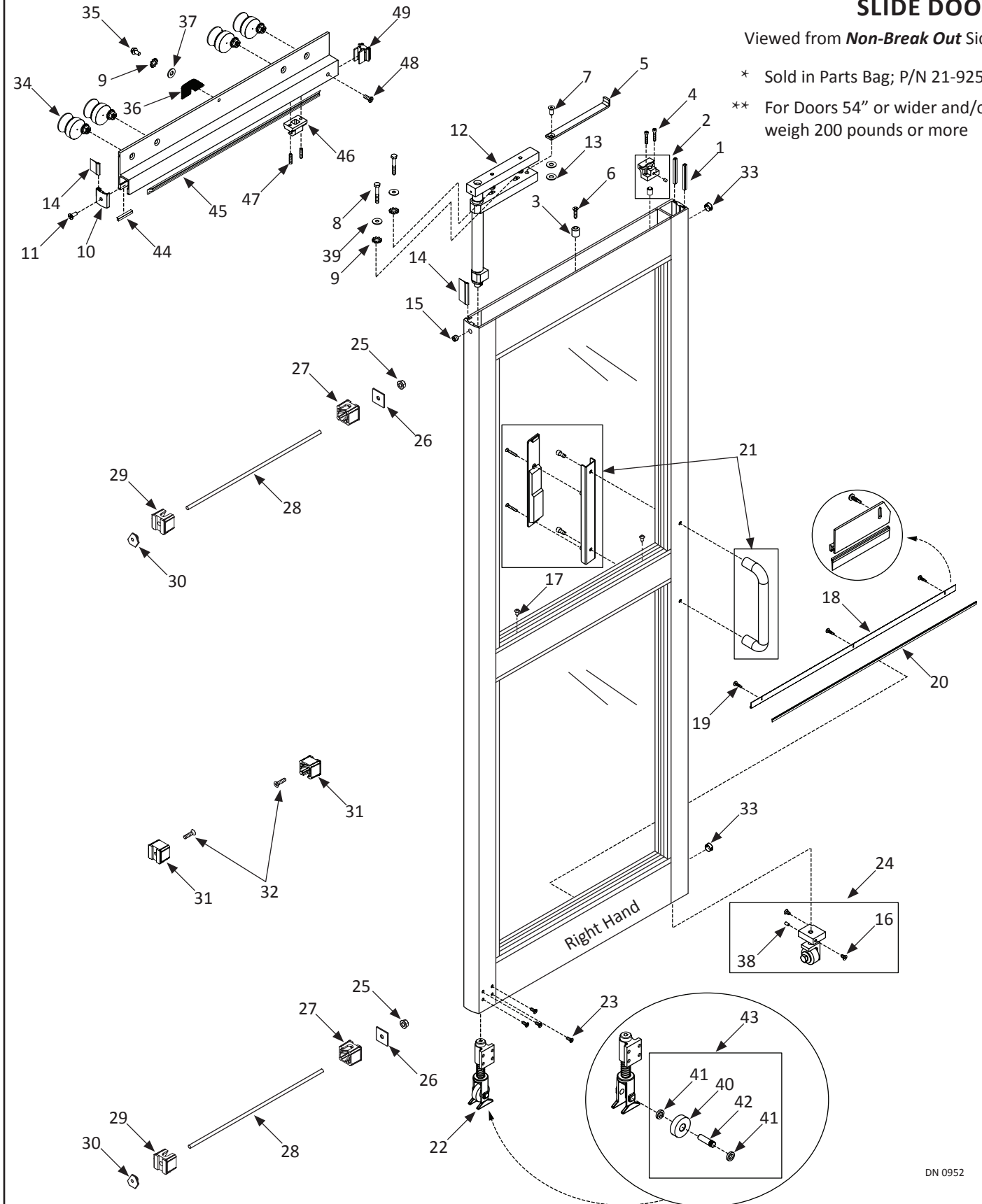

DN 0952

SERVICE PARTS: LEFT HAND SLIDE DOOR

Viewed from *Non-Break Out Side*

* Sold in Parts Bag; P/N 21-9251

** For Doors 54" or wider and/or weigh 200 pounds or more

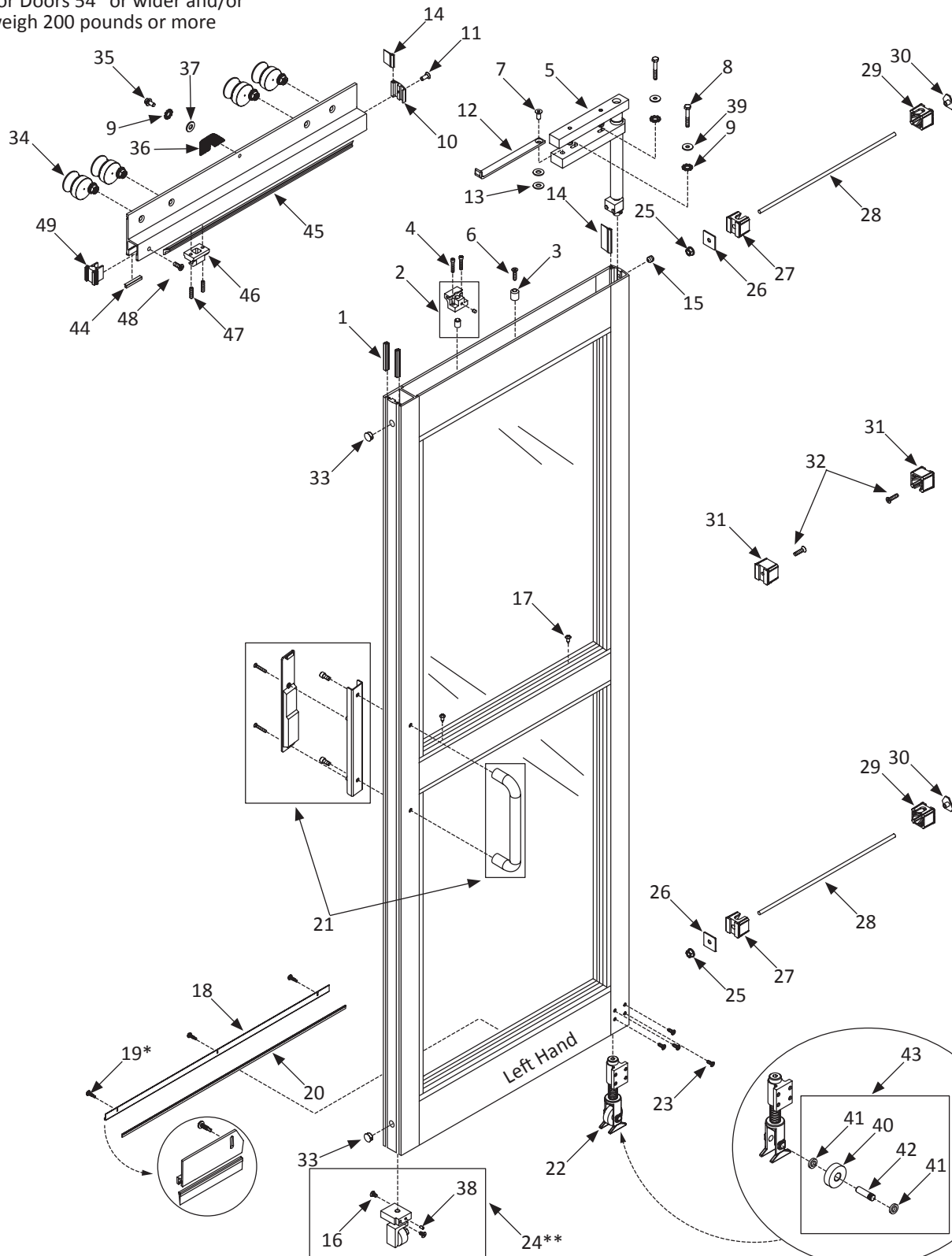

DN 0953

Slide Door			
Item	Part	Finish/Sizes/Notes	Description
1	14-8632		WEATHERING TRI POLY BLACK BULB
2	21-3468-99		PANIC CATCH RELEASE ASSY, MODEL 1100
3	14-8447		LIMIT ARM SUPPORT
4	24-0010-16		SHCS, 1/4-20 X 1 1/4"
5	21-8396		LIMIT ARM, STD STILES
6	24-4941-02	Zinc	FHMS, 1/4-20 X 1", PHIL, TRILOBE, ZN
7	24-0011-77	Zinc	FHCS, 7/16-14 X 1", ZN
8	24-0014-12		HHCS, 1/4-20 X 1 3/4"
9	24-0019-05		1/4" EXTERNAL STAR WASHER
10	14-10561-01	Clear	END CAP, PIVOT - TRAIL DOOR MILLED 204
	14-10561-02	Dark Bronze	END CAP, PIVOT - TRAIL DOOR 313
11	24-0011-130	Black Zinc	FHMS 10-32X1/2" PHIL TYP 23, UND, BLK ZN
	24-0011-131	Zinc	FHMS, 10-32X1/2", PHIL, TYP 23, UND, ZN
12	24-12002-10		CARRIER PVT ASSY NARROW STILE-UL PART
	24-12002-20		CARRIER PVT ASSY MED STILE-UL PART
	24-12002-30		CARRIER.PVT ASY - NRW STL-PNL <22.75-UL
	24-12002-40		CARRIER.PVT ASY - MD STL- PNL < 22.75"UL
13	24-0017-02		WASHER, 7/16 ID X 1 OD X .083 THK
14	14-5592-01	Smoke Seal Only/Gray	WEATHER STRIP - 9/16 IN VINYL FIN, GRAY
	14-5592-02	Smoke Seal Only/Black	WEATHER STRIP - 9/16 IN VINYL FIN, BLACK
15	24-0016-51	Black Oxide	SHSS, 5/16-24 X 5/16" CUP PT, BLK OX
16	24-0011-70	Zinc	FHMS, 1/4-20 X 7/16", PHIL, UND, ZN
	24-0011-73	Black Oxide	FHMS, 1/4-20 X 7/16", PHIL, UND, BLK OX
17	24-0094-01		PHSMS, 10 X 1/2", PHIL, TYPE A
18	24-9125-01	Smoke Seal Only/Clear	WEATHERING EXT, 204
	24-9125-02	Smoke Seal Only/Dark Bronze	WEATHERING EXT, 313
19	24-0013-03	Smoke Seal Only/Zinc	PHSMS, 6 X 1/2", PHIL, TEKS, ZN
	24-0013-04	Smoke Seal Only/Black Zinc	PHSMS, 6 X 1/2", PHIL, TEKS, BLK ZN
20	14-3933-01	Smoke Seal Only/Gray	WEATHERING GRAY VINYL 1 IN FIN
	14-3933-02	Smoke Seal Only/Black	WEATHERING BLACK VINYL 1 IN FIN
21	12-12958-01	Clear	KIT, ICU D/RECESSED HANDLE
	12-12958-02	Dark Bronze	KIT, ICU D/RECESSED HANDLE
22	21-9053-01		BTM GUIDE ASSY - CAST NRW STILE-UL PART
23	24-0011-53		FHMS, 10-32 X 1/2, PHIL, UL PART
24	14-5543-11	Clear	NOSE CASTER ASSY NARROW STILE
	14-5543-12	Dark Bronze	NOSE CASTER ASSY
	14-5543-21	Clear	NOSE CASTER ASSY MED. STILE
	14-5543-22	Dark Bronze	NOSE CASTER ASSY
25	24-0021-21	Zinc	NUT, WHIZLOCK, 3/8-16, ZN
26	14-9225		BACKING PLATE, TIE ROD - DOOR ASSEMBLY

Slide Door			
Item	Part	Finish/Sizes/Notes	Description
27	24-9504		CLIP, MUNTIN BAR - RAIL .386 HOLE
28	14-3624	Zinc	THREADED ROD, 3/8"-16 - ZINC PLATED
29	24-9503		CLIP, MUNTIN BAR - RAIL .500 HOLE
30	14-9279		OFFSET TEE NUT, 3/8"-16
31	24-9502		CLIP, MUNTIN BAR - RAIL .261 HOLE
32	24-4941-02	Zinc	FHMS, 1/4-20 X 1", PHIL, TRILOBE, ZN
33	14-9511-04		PLUG, HOLE, .813 DIAMETER, BLK
34	12-10027		30mm HANGER ROLLER & HUB SUBASSY
35	24-0014-39	Green	HWHMS, 1/4-20 X 3/8", SLOT, GREEN
36	14-10907-01		STATIC ARRESTOR STRIP 4"
37	24-0017-46		WASHER, FLAT 1/4X5/8X.051/.080
38	24-0016-05		SHSS, 8-32 X 5/16, CUP PT
39	24-0017-04		WASHER, 1/4 ID X 9/16 OD X .049 THK, STL
40	14-9045-01		BTM ROLLER DOOR URETHANE-ULPART
	14-9045-02		BTM RLR DOOR URETH MED STILE-UL PART
41	24-0667-01		SPACER, MOUNTING - END CAP-UL PART
42	14-7061		SHAFT, ROLLER-UL PART
43	14-11320-10		KIT, ASSY, REPAIR, GT1175, NARROW STILES
	14-11320-20		KIT, ASSY, REPAIR, GT1175, MEDIUM STILES
44	14-2279-04	Smoke Seal Only	PILE WEATHERING, BLK, .20 TALL, CARRIER
45	24-9094-01	Clear	INTERFACE LEG - 204
	24-9094-02	Dark Bronze	INTERFACE LEG - 313
46	24-9483		PANIC CATCH, UPPER PART
47	24-0016-30		SHSS, 5/16-18 X 1.25", CUP
48	24-0011-105	Zinc	FHMS, 10-32 X 1/2", PHIL, UND, ZN
49	12-10882-01	Clear	CAP, END STRIKE SIDE ASSY. BULB
	12-10882-02	Dark Bronze	CAP, END CARRIER STRIKE SIDE ASSB 313