



GT2100 Full Open, no Track Self Close Slide Door
Quick Set-Up Parts Guide
P/N C-00094 Rev 8-18-14

Nabco Entrances Inc. S82 W18717 Gemini Drive Muskego, Wisconsin 53150
Phone: (877) 622-2694 Fax: (888) 679-3319 www.nabcoentrances.com

*Associated Manuals Part Numbers: "GT 2100 Manual Slider Installation Manual" (P/N 15-10791)
Manual Slide Door Owner's Manual (P/N C-00189) for Decal Installation
NABCO Price Book" for Sensors, Switches, and Accessories (P/N 16-9244-30)*

WARNING

Instruct the Owner to keep all power turned OFF until corrective action can be achieved by a NABCO trained technician. Failure to follow these practices may result in serious consequences

Table of Contents

1 INSTALL FRAME 2

2 INSTALL THE FULL OPEN SIDELITE PANEL 2

3 INSTALL THE SLIDE DOOR 2

4 ADJUSTMENTS 2

5 SELF CLOSE HEADER 3

SERVICE PARTS: HEADER 6

SERVICE PARTS: CARRIER 8

SERVICE PARTS: FULL OPEN SIDELITE 9

SERVICE PARTS: RIGHT HAND FULL OPEN SIDELITE 10

SERVICE PARTS: LEFT HAND FULL OPEN SIDELITE 11

SERVICE PARTS: SLIDE DOOR 14

SERVICE PARTS: RIGHT HAND SLIDE DOOR 15

SERVICE PARTS: LEFT HAND SLIDE DOOR 16

1 Install Frame

1. Go to the non-breakout side of rough opening. Place Header on a flat surface with the removable cover facing up.
2. Refer to the instruction sticker located on each Jamb Tube to properly orientate Jamb Tubes.
3. Remove Cover from Header. Remove Parts boxes and/or Parts bags from inside Header. Set aside.
4. Secure Frame to Rough Opening with 1/4 inch diameter anchors or 3/8 inch threaded rods, with a maximum 48 inches on center for the Header and Jamb Tubes (First anchor maximum is 36 inches from each end of the Header).

2 Install the Full Open Sidelite Panel

1. Center and butt the Bottom Pivot Assembly up against the inside, side of the Pivot Jamb Tube so the Bottom Bushing is on the Breakout side of opening.
2. With a 1/4 inch Masonry drill bit, drill through each screw hole at least 1-1/2 inches deep. Remove the Bottom Pivot.
3. Insert (1) #16 Hi-Red Anchor into each drilled hole. Replace the Bottom Pivot.
4. Permanently secure the Bottom Pivot to the Floor by screwing (1) #14 x 1-1/2 inch Phillips Head Screws into the #16 Hi-Red Anchors. Cap the Bottom Pivot Barrel with Bushing.
5. Insert the Pivot Pin (located at the bottom of the Pivot Stile within the Sidelite Panel) into the Bottom Pivot Bushing.
6. Push the Retracting Pin (located at the top of the Pivot Stile within the Sidelite Panel) down until it is aligned with the Retracting Pivot Pin hole (located at the bottom of Header). Let go of the Retracting Pin so it can snap into hole. It may be necessary to lift up the Retracting Pin with a screwdriver so it can fully engage the hole.
7. Fully open and close the Sidelite Panel to check for obstructions. If deemed necessary, adjust the Sidelite Panel by adding or removing (1-3) Washers from the Bottom Pivot.
8. Drill (1) hole at the bottom of Header for the Flush Bolt (located at the top of Strike Stile) to lock into.
9. Secure the Bottom Guide to the bottom of Strike Stile with (2) 1/4" Star Washers and (2) 1/4 - 20 x 3/4" Hex Cap Screws.

3 Install the Slide Door

1. Cover the Sidelite Panel with cardboard on the non-breakout side.
2. Remove each Roller located at the front of Carrier. Refer to the instruction sticker to reinstall each Roller to the back of Carrier.
 - a. Ensure each Roller is horizontally aligned to each other. Please see Figure 1.

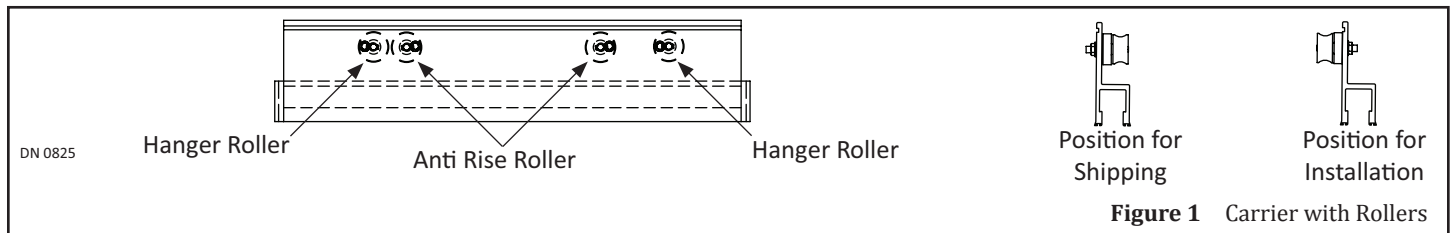

Figure 1 Carrier with Rollers

3. Slightly tilt the Slide door to make it easier for the (4) Rollers to 'catch' onto the track.
4. With the Slide Door tilted install the Carrier onto the Track and on top of the Bottom Guide.
5. Adjust the Slide Door in Section "4 Adjustments".

4 Adjustments

4.1 Adjust Height on Slide Door

CAUTION

Do Not rotate the stud counter-clockwise. Doing so will unthread the Axle from the Hanger Roller assembly.

1. Measure the gap between the door and the floor. The gap must be between 3/16" to 7/16" (3/8" nominal).
2. Loosen each Hanger Roller Nut. It is recommended to adjust the (2) Hanger Rollers located at each end of door first.
3. Turn each axle clockwise to raise or lower the Sliding door. Retighten each Hanger Roller nut. Do not overtighten.
4. Loosen each Anti-Rise Roller nut. Turn each axle clockwise until each Anti-Rise Roller almost makes contact with the top of Roller Track. Gap should be about the same thickness of a credit card. Retighten each Anti-Rise Roller nut. Do not overtighten.

4.2 Adjust Preload on Slide Door

CAUTION

Glass must be installed first before adjusting Preload on Slide Door.

CAUTION

When a Preload Block is shifted, it will be necessary to gently tap on one end of the Interface Leg (located inside the Carrier) until it is properly recentered.

1. Support the weight of sliding door. Breakout sliding door approximately 75 degrees. Check for door sag.
2. Go to the Preload Block located inside the Top Rail. Loosen (2) Locking Bolts.
3. Go to the back edge of Pivot Stile. Reduce door sag by tightening the 5/16 inch Adjustment Set Screw with a 5/32 inch Allen Wrench.
 - a. The door should lift without having to be manually lifted.
 - b. Do not allow the Adjusting Set Screw to protrude more than 5/32 inch past the end of stile.
 - c. If an optional 1/2 inch Adjustment Set Screw provided by NABCO is deemed necessary, it could mean the Preload is misaligned. Go to Section 4.3 before replacing the 5/32 inch Adjustment screw.

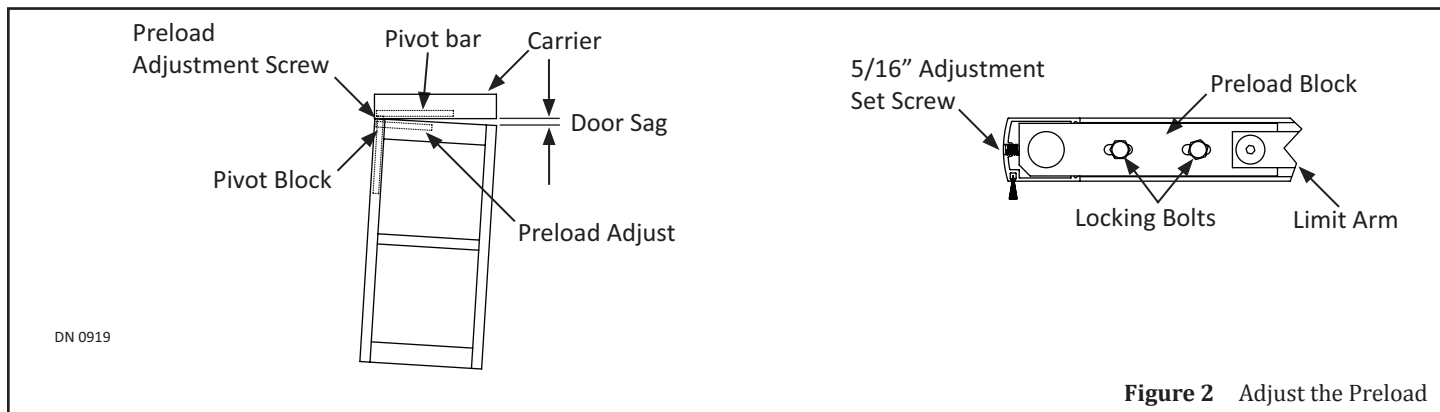

Figure 2 Adjust the Preload

4.3 Correct Preload Misalignment

1. Check to see if misalignment exists on the Strike end of the Door and Carrier.
2. Loosen the Allen head fasteners on the Pivot bar that is located inside the Carrier. Slide the Pivot bar until the door and Carrier are properly aligned.
3. Verify that the Panic Catch inside the Top Rail and the Carrier are still aligned. If not, loosen the 5/16 inch set screw to align the Carrier Panic Catch with the Top Rail Panic Catch.

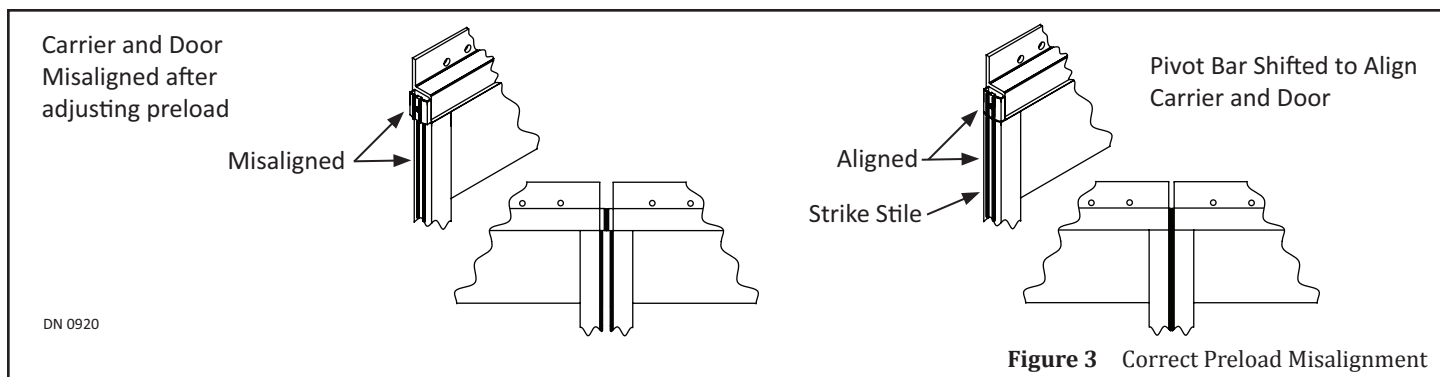

Figure 3 Correct Preload Misalignment

4.4 Adjust the Nose Caster

Note: Nose Casters are pre-installed for Sliding Doors that are 54 inches Wide (or greater) and/or over 200 pounds.

1. Loosen the #8-32 Set Screw.
2. Position the Wheel so it is perpendicular to the Bottom Rail.
3. Retighten the #8-32 Set Screw.
4. Break open the Slide door. Ensure the Slide door does not scrape the floor. If it does lower the Nose Caster further.

5 Self Close Header

5.1 Wire Components within Header

1. Ensure all power is disconnected at the Junction box and Slide door unit. Inspect the location and grade of all Incoming 120 VAC power cables.
2. Wire the components according to illustration shown below.

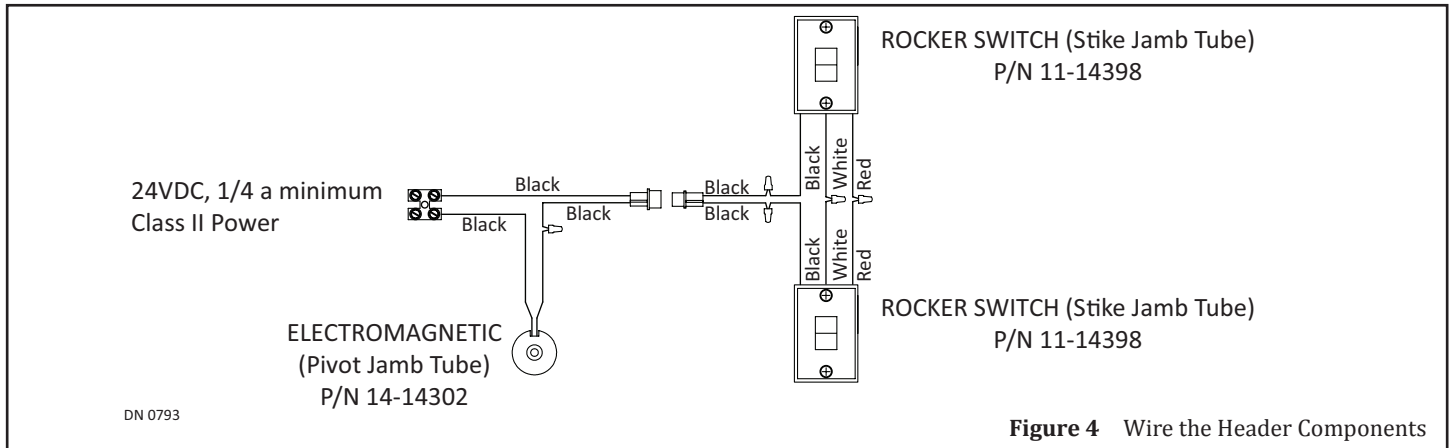

Figure 4 Wire the Header Components

5.2 Align the Rotary Damper to the Control Rack

- Loosen (2) #10 Hex nuts that are used to secure the Rotary Damper to the Header. Slide open the door until the Rotary Damper is directly underneath the Control Rack. Slide the Rotary Damper up the slot until the teeth can fit inside the Control Rack teeth. Slide door back and forth to check for binding or chatter.

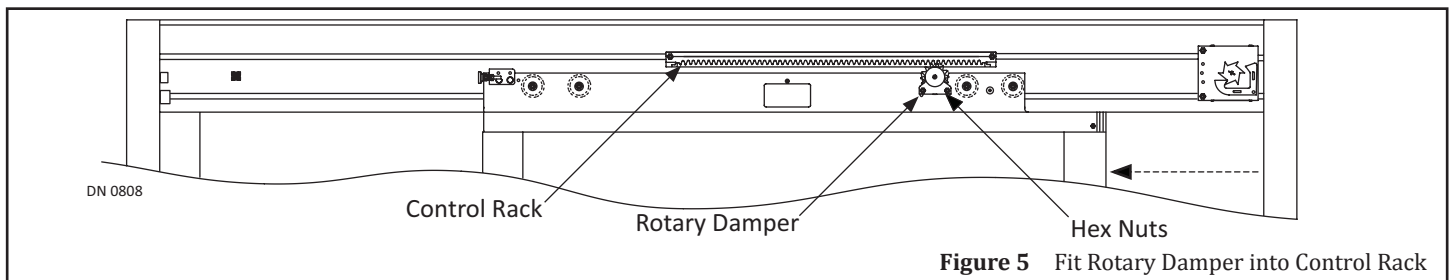

Figure 5 Fit Rotary Damper into Control Rack

5.3 Attach the Pull Spring to the Carrier

- Close the Slide door. Go to the Shoulder Bolt located between (2) Hanger Rollers closest to the Strike Jamb. Remove the Shoulder Bolt with a 3/16 inch Allen Wrench.
- Attach the Pull Spring to the Shoulder Bolt. Reinstall the Shoulder Bolt with the Pull Spring attached.

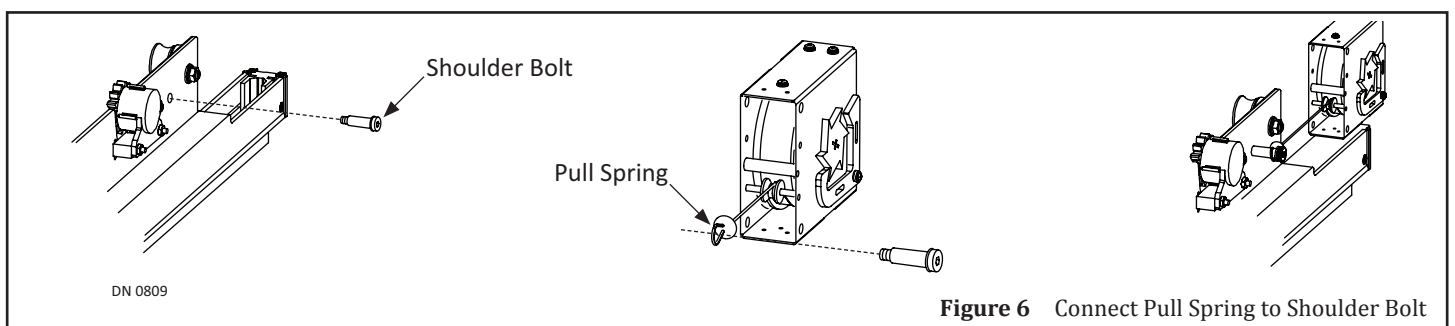
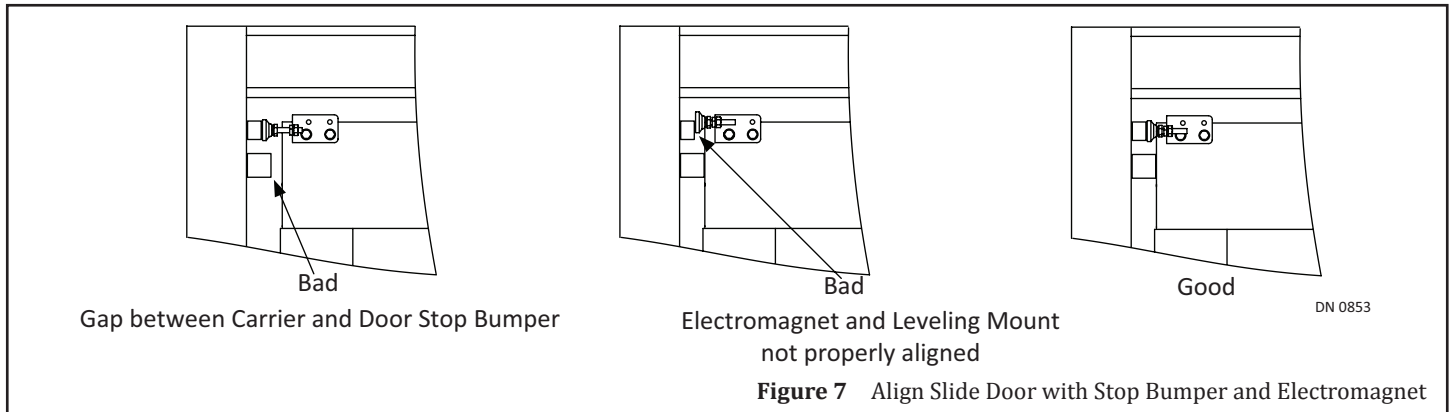

Figure 6 Connect Pull Spring to Shoulder Bolt

5.4 Align Slide Door with Electromagnet and Door Stop Bumper

- Loosen (2) Hex nuts on the Magnetic Strike. Slide the Carrier until it is against the Slide door Bumper.
- While holding the Carrier to the Slide door Bumper, adjust the Magnetic Strike to contact and align with the Magnet on the Jamb Tube. Tighten Hex Nuts.



5.5 Adjust Closing Speed if Slide door does not Fully Close (Self Close Units)

1. Open the Slide door. Allow Slide door to fully close. It should close slowly. If Slide door does not close slowly, go to the Pull Spring. With a Flathead screwdriver turn the Tension plate counterclockwise to increase tension.

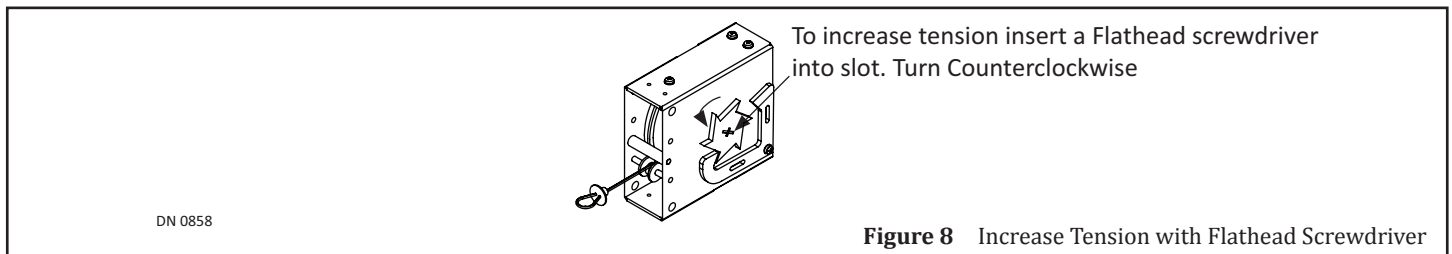

5.6 Adjust Closing Speed if Slide door closes Too Fast (Self Close Units)

1. Go to the Pull Spring.
2. With both index fingers carefully push the Tension Bracket forward so the Tension Plate clicks clockwise. This will decrease tension on the Pull Spring.
3. With both thumbs push the Tension Bracket back to starting position. Do not pinch fingers while setting the tension.
4. For more speed control, adjust the Rotary Damper (turn the dial clockwise to increase damping, counterclockwise to decrease damping).

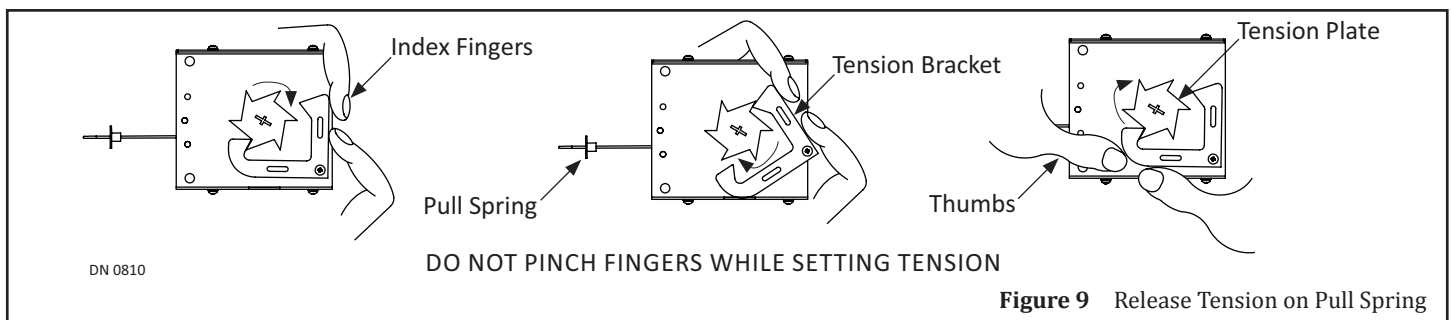

5.7 Fine Tune the Latching Speed

- ▶ To increase Latching speed:
 1. Move the Control Rack farther away from the Strike Jamb Tube.
 2. Adjust the Pull Spring and Rotary Damper after moving the control rack.
- ▶ To decrease Latching speed:
 1. Move the control rack closer to the Strike Jamb Tube. Slide door will move faster before hitting the Control Rack.
 2. Adjust the Pull Spring and Rotary Damper after moving the Control Rack.

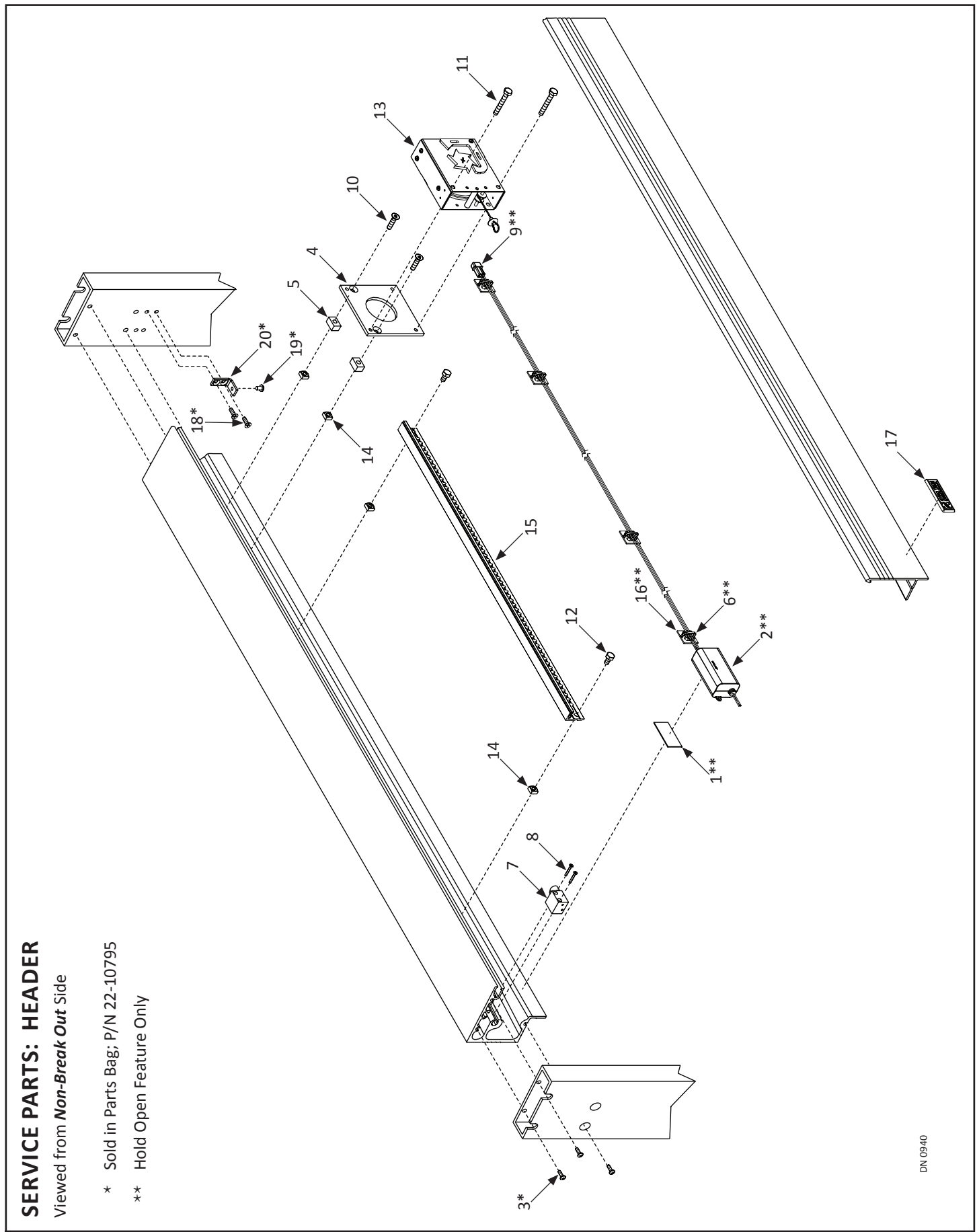

SERVICE PARTS: HEADER

Viewed from *Non-Break Out* Side

* Sold in Parts Bag; P/N 22-10795

** Hold Open Feature Only

DN 0940

Header			
Item	Part	Finish/Sizes/Notes	Description
1	14-13769	Hold Open Feature Only	TAPE, DBL. SIDE, FOAM 1" X 2" .045THK
2	14-14299	Hold Open Feature Only	POWER SUPPLY, 24VDC
3	24-0015-61	Zinc	RHMS,1/4-20 X 3/4" PHIL, TYPE F, ZN
4	14-14326		PULL SPRING MOUNTING BRACKET
5	14-14327		PULL SPRING SPACER
6	14-1473-10	Hold Open Feature Only	CABLE TIE, 4"
7	11-14344-10	RH/Hold Open Feature Only	ASSY,SELF CLSG ICU STOP, RH
	11-14344-20	LH/Hold Open Feature Only	ASSY, SELF CLS.ICU DR STP,LH
	12-10714	RH/No Hold Open Feature	END STOP ASSEMBLY - RH
	12-10829	LH/No Hold Open Feature	END STOP ASSEMBLY - LH
8	24-0011-52	For Hold Open Feature	FHMS,1/4-20 X 1 3/4,SKT
	24-0011-09	For No Hold Open Feature	FHMS,1/4-20 X 1,PHILLIPS
9	11-14352	Hold Open Feature Only	SELF-CLOSER HOLD OPEN HEADER HARNESS
10	24-0011-21	Zinc	FHCS, 1/4-20 X 1", ZN
11	24-0014-12		HHCS,1/4-20 X 1 3/4"
12	24-0014-23		HHCS,1/4-20 X 1/2"
13	14-14316		MACHINED PULL SPRING
14	24-0021-27		SQUARE NUT, 1/4-20
15	24-14304		MACHINED CONTROL RACK
16	24-9442	Hold Open Feature Only	TIE MOUNT ADHESIVE BACKED
17	14-9199		NAMEPLATE, ADHESIVE BACKED
18	24-0011-70	Zinc	FHMS, 1/4-20 X 7/16", PHIL, UND, ZN
19	24-0015-22	Zinc	RHMS,#8-32 X 1/4", PHIL, ZN
20	14-10727		CLIP, COVER

SERVICE PARTS: CARRIER

Viewed from *Non-Break Out Side*

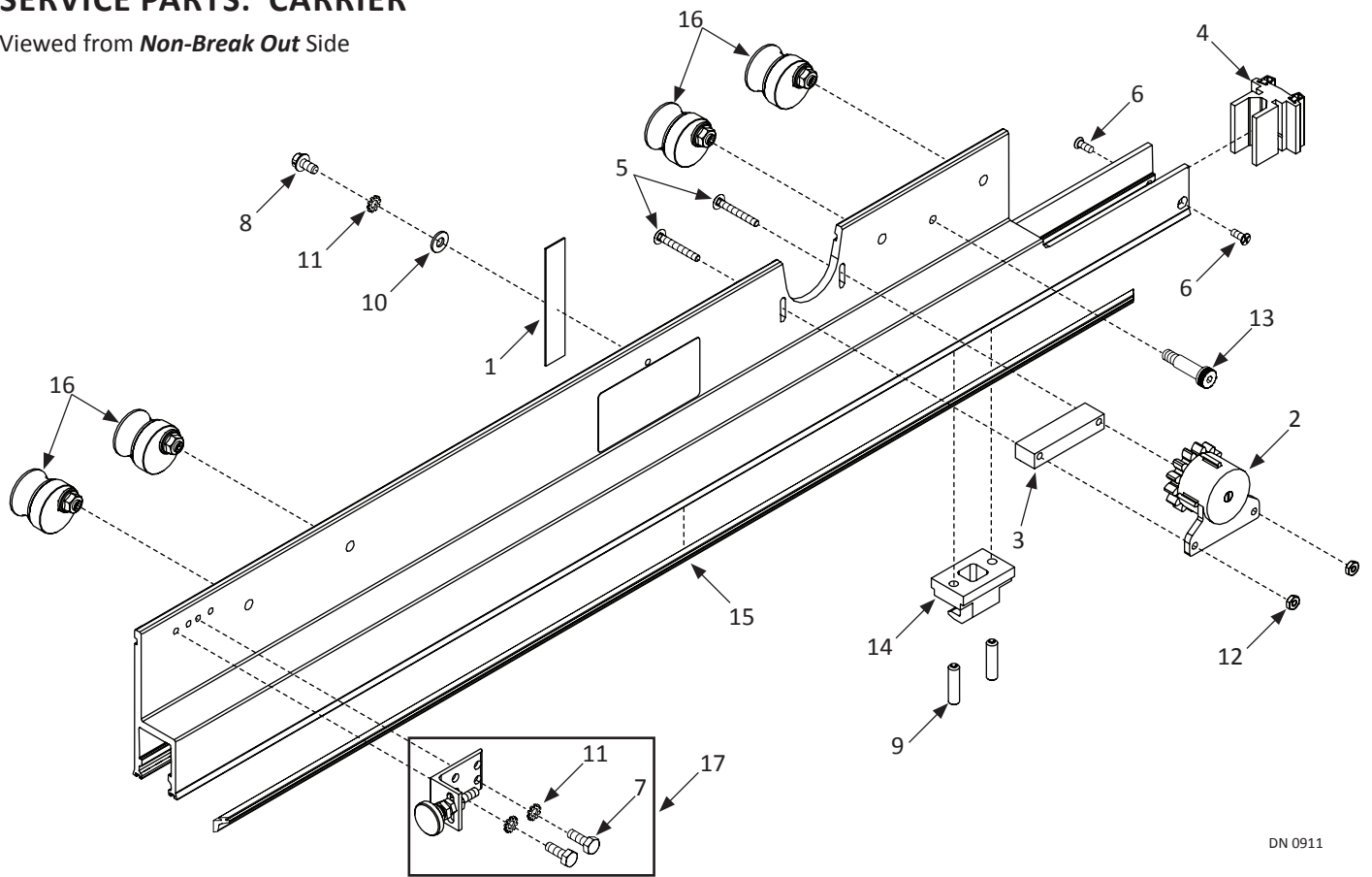

DN 0911

Carrier

Item	Part	Finish/Sizes/Notes	Description
1	14-10907-01		STATIC ARRESTOR STRIP 4"
2	14-13959-10		ROTARY DAMPER, RIGHT HAND, SC-C08
	14-13959-20		ROTARY DAMPER, LEFT HAND, SC-C08
3	14-14313		ROTARY DAMPER SPACER
4	14-14321		END CAP, MACHINED SELF-CLOSER CARRIER
5	14-14329	Zinc	CARRIAGE SCREW,10-24 X 1.5", ZN
6	24-0011-105	Zinc	FHMS, 10-32 X 1/2", PHIL, UND, ZN
7	24-0014-02	Zinc	HHCS, 1/4-20 X 3/4", ZN
8	24-0014-39	Green	HWHMS, 1/4-20 X 3/8", SLOT, GREEN
9	24-0016-30		SHSS, 5/16-18 X 1.25", CUP
10	24-0017-46		WASHER, FLAT 1/4X5/8X.051/.080
11	24-0019-05		1/4" EXTERNAL STAR WASHER
12	24-0021-04		HEX NUT #10-24
13	24-1247-07		BOLT, SHOULDER 3/8" DIA X 1"
14	24-9483		PANIC CATCH, UPPER PART
15	24-9094		DOOR CARRIER INTERFACE LEG
16	12-10027		30mm HANGER ROLLER & HUB SUBASSY
17	11-14325-10		ASSY, RH HOLD OPEN BRKT

SERVICE PARTS: FULL OPEN SIDELITE

Viewed from *Non-Break Out* Side

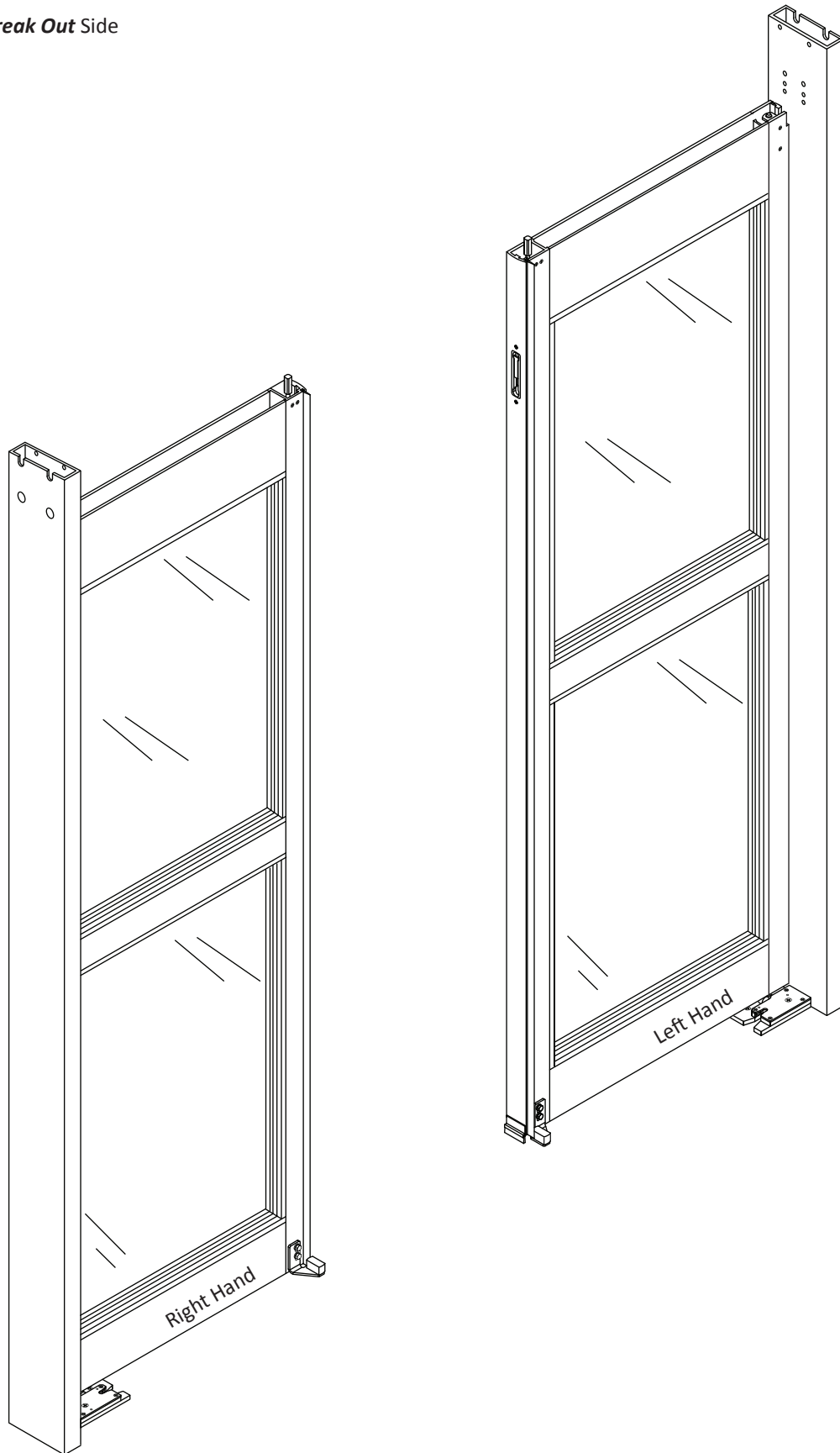

DN 0921

SERVICE PARTS: RIGHT HAND FULL OPEN SIDELITE

Viewed from *Non-Break Out* Side

* Sold in Parts Bag; P/N 22-10795

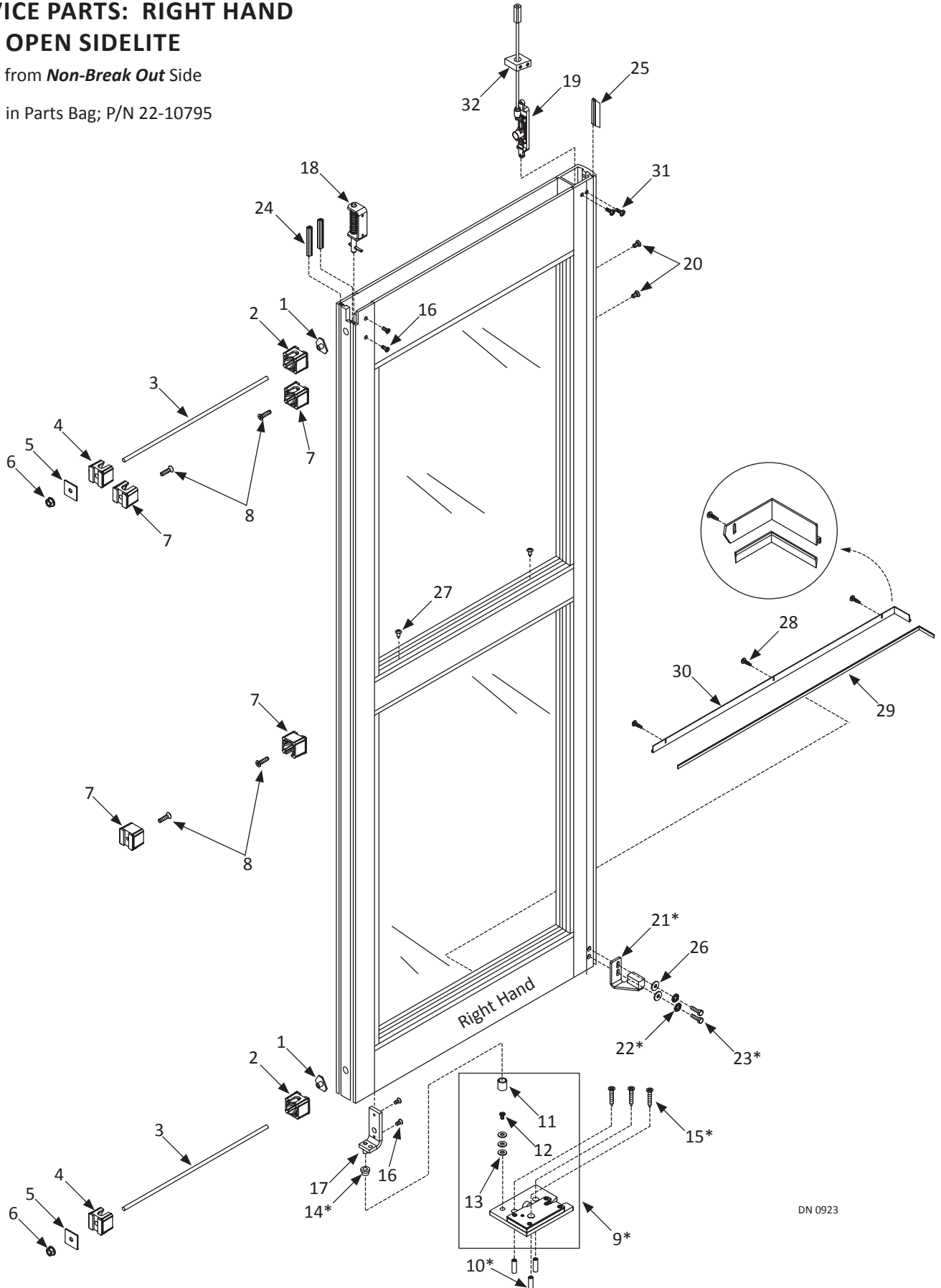

DN 0923

SERVICE PARTS: LEFT HAND FULL OPEN SIDELITE

Viewed from *Non-Break Out* Side

* Sold in Parts Bag; P/N 22-10795

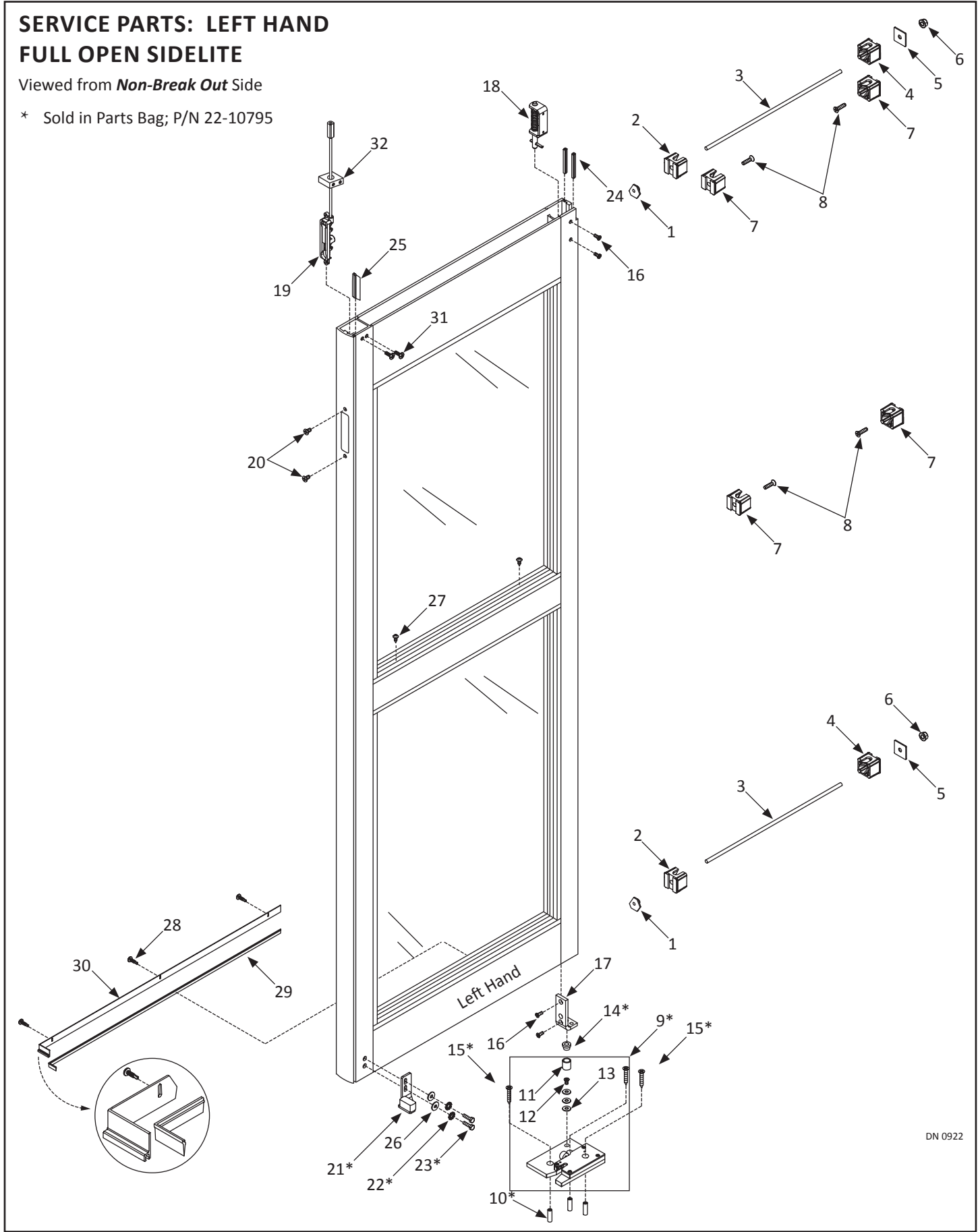

DN 0922

Sidelite			
Item	Part	Finish/Sizes/Notes	Description
1	14-9279		OFFSET TEE NUT, 3/8"-16
2	24-9503		CLIP, MUNTIN BAR - RAIL .500 HOLE
3	14-3624	Zinc	THREADED ROD, 3/8"-16 - ZINC PLATED
4	24-9504		CLIP, MUNTIN BAR - RAIL .386 HOLE
5	14-9225		BACKING PLATE, TIE ROD - DOOR ASSEMBLY
6	24-0021-21	Zinc	NUT, WHIZLOCK, 3/8-16, ZN
7	24-9502		CLIP, MUNTIN BAR - RAIL .261 HOLE
8	24-4941-02	Zinc	FHMS, 1/4-20 X 1", PHIL, TRILOBE, ZN
9	12-10796		PIVOT ASSY 2 PANEL RH
	12-10797		PIVOT ASSY 2 PANEL LH
10	14-1018		ANCHOR - PLASTIC #14 X 1 BLUE
11	14-10724		BOTTOM PIVOT - SWING PANEL
12	24-0011-13		FHMS, 1/4-20 X 3/4", PHIL, ZN
13	24-0017-14		WASHER, 5/16 ID X 3/4 OD X .062 THK
14	24-2458		BOTTOM PIVOT BUSHING, SWING PANEL
15	24-0031-21		FHSMS, 14 X 1 1/2", TYPE A, PHIL
16	24-0011-105		FHMS, 10-32 X 1/2", PHIL, UND, ZN
17	11-9509-02	RH	BOTTOM PIVOT SWING PANEL ASSY - RH
	11-9509-01	LH	BOTTOM PIVOT SWING PANEL ASSY - LH
18	21-9507		ASM, TOP PIVOT, 1175 SWING PANEL
19	24-5505-01	Clear	FLUSH BOLT MACHINED
	24-5505-02	Dark Bronze	FLUSH BOLT MACHINED
20	24-0011-72		FHMS, 10-24 X 3/8", PHIL, UND
21	12-12409	LH	GUIDE BLOCK SUB ASSY NARROW STILE - LH
	12-12410	RH	GUIDE BLOCK SUB ASSY NARROW STILE - RH
	12-12411	LH	GUIDE BLOCK SUB ASSY MEDIUM STILE - LH
	12-12412	RH	GUIDE BLOCK SUB ASSY MEDIUM STILE - RH
22	24-0019-05		1/4" EXTERNAL STAR WASHER
23	24-0014-01	Zinc	HHCS, 1/4-20 X 1", ZN
24	14-8632	Black	WEATHERING TRI POLY BLACK BULB
25	14-5592-01	Smoke Seal Only/Gray	WEATHER STRIP - 9/16 IN VINYL FIN, GRAY
26	14-5592-02	Smoke Seal Only/Black	WEATHER STRIP - 9/16 IN VINYL FIN, BLACK
27	24-0017-04		WASHER, 1/4 ID X 9/16 OD X .049 THK, STL
28	24-0094-01		PHSMS, 10 X 1/2", PHIL, TYPE A
	24-0013-03	Smoke Seal Only/Zinc	PHSMS, 6 X 1/2", PHIL, TEKS, ZN
29	24-0013-04	Smoke Seal Only/Black Oxide	PHSMS, 6 X 1/2", PHIL, TEKS, BLK ZN
	14-3933-01	Smoke Seal Only/Gray	WEATHERING GRAY VINYL 1 IN FIN

Sidelite			
Item	Part	Finish/Sizes/Notes	Description
30	14-3933-02	Smoke Seal Only/Black	WEATHERING BLACK VINYL 1 IN FIN
	14-10659-01	Smoke Seal Only/LH/Clear	WEATHERING HOLDER
	14-10659-02	Smoke Seal Only/LH/Dark Bronze	WEATHERING HOLDER
	14-10660-01	Smoke Seal Only/RH/Clear	WEATHERING HOLDER
31	14-10660-02	Smoke Seal Only/RH/Dark Bronze	WEATHERING HOLDER
32	24-4941-18		PHMS, 10-32 X 1/2", PHIL, TYPE F
	24-10774		LOCK ROD GUIDE - PLASTIC LOCK ROD END

SERVICE PARTS: SLIDE DOOR

Viewed from *Non-Break Out* Side

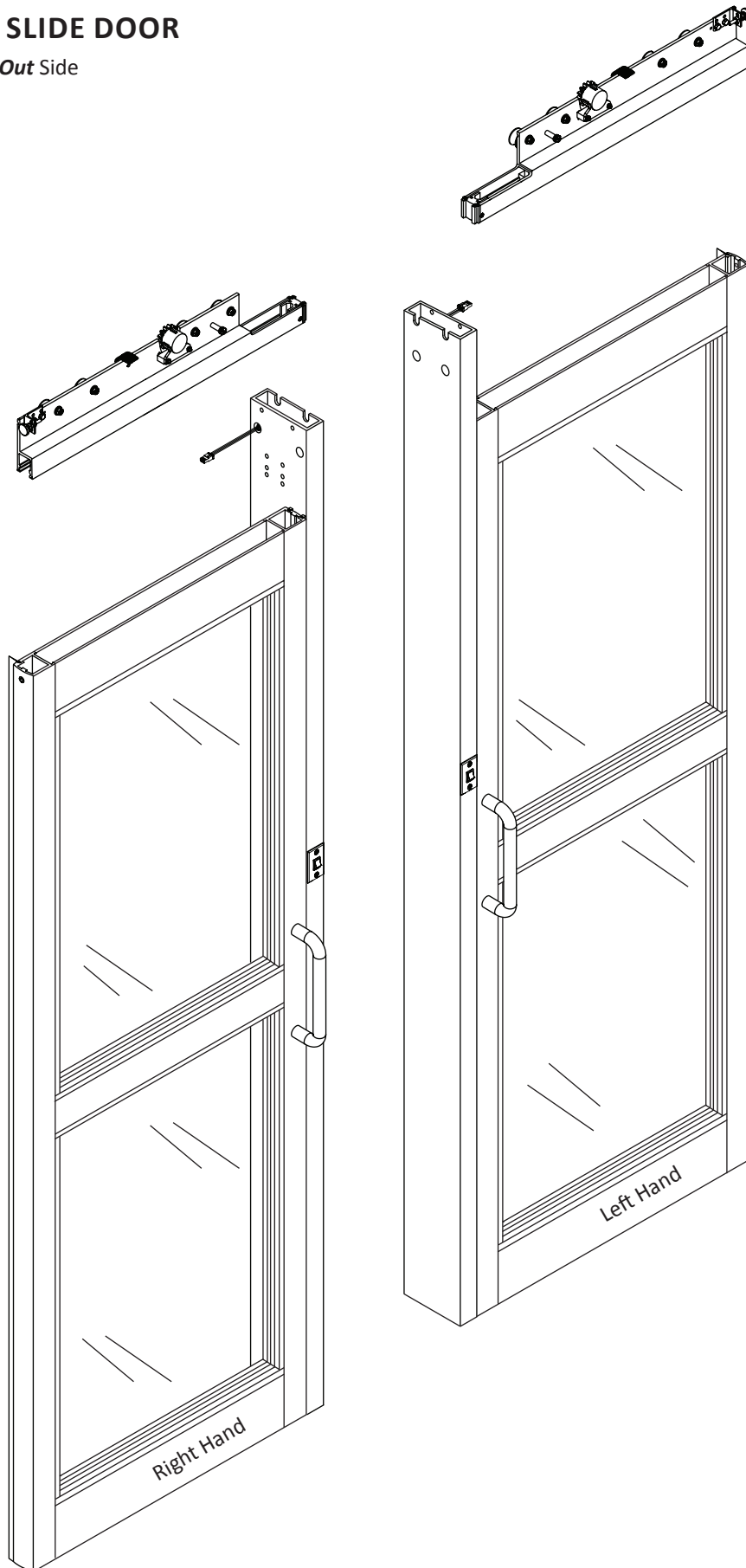

DN 0913

SERVICE PARTS: RIGHT HAND SLIDE DOOR

Viewed from *Non-Break Out Side*

* Sold in Parts Bag; P/N 22-10795

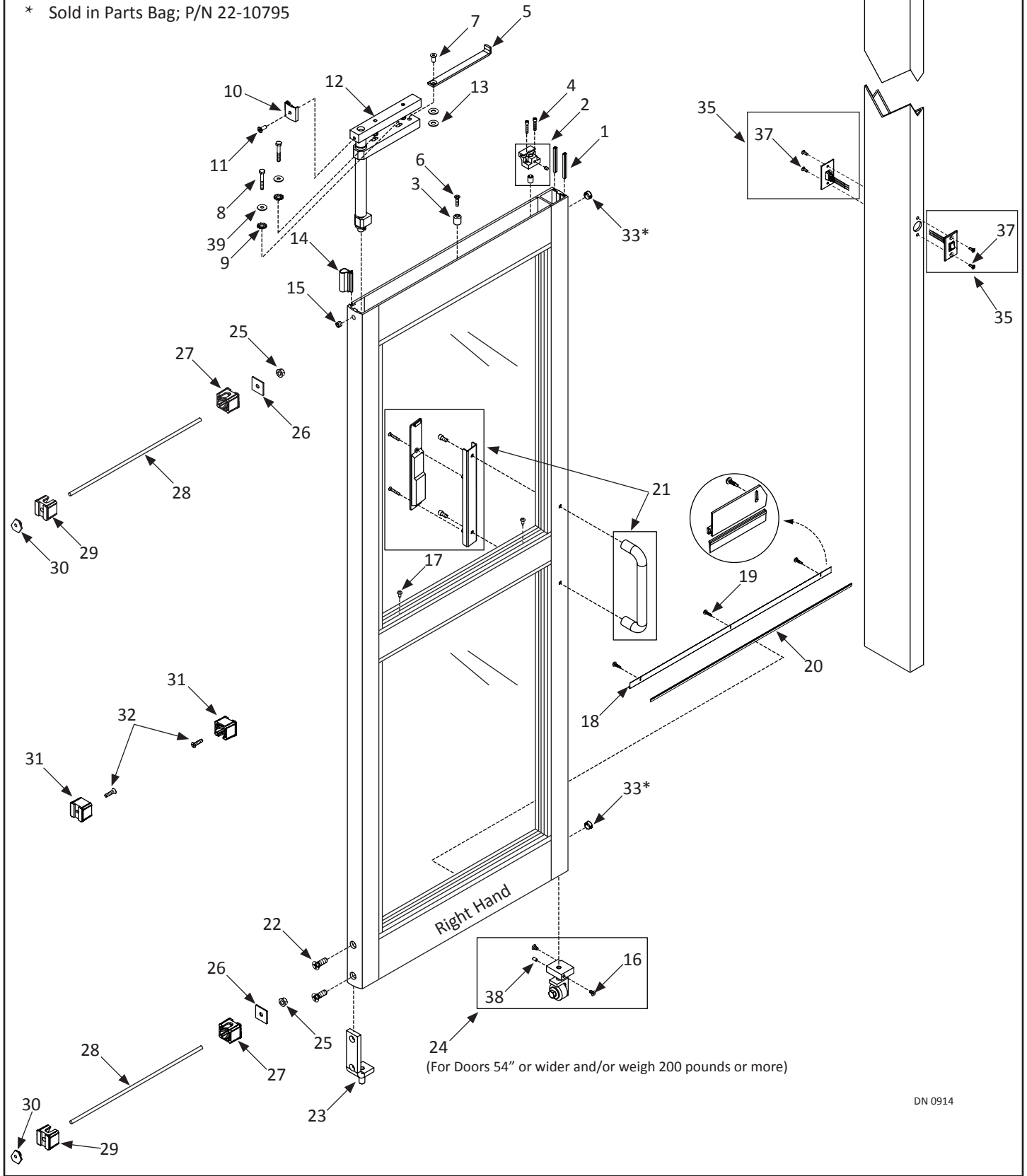

DN 0914

SERVICE PARTS: LEFT HAND SLIDE DOOR

Viewed from *Non-Break Out* Side

* Sold in Parts Bag; P/N 22-10795

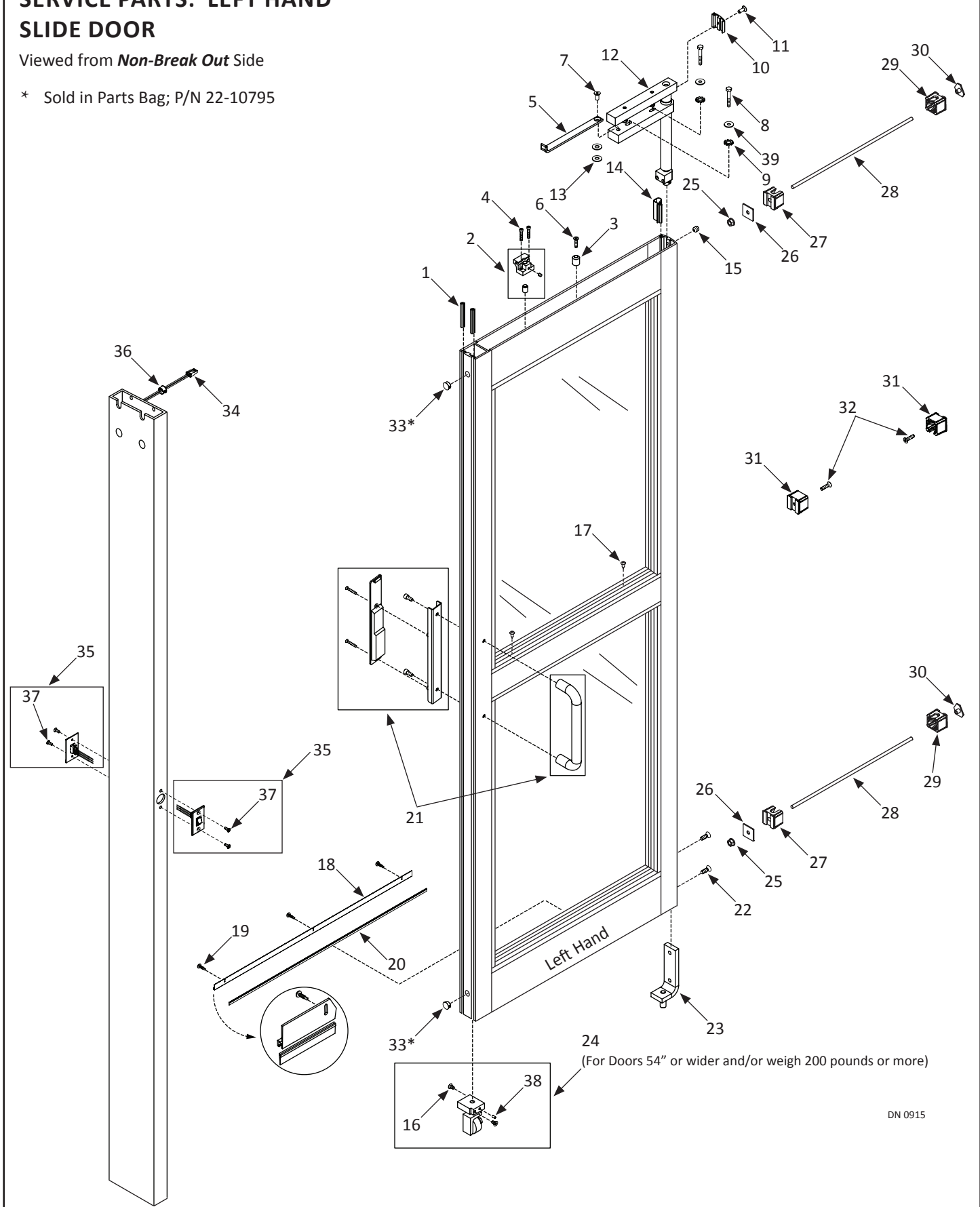

DN 0915

Slide Door			
Item	Part	Finish/Sizes/Notes	Description
1	14-8632		WEATHERING TRI POLY BLACK BULB
2	21-3468-99		PANIC CATCH RELEASE ASSY, MODEL 1100
3	14-8447		LIMIT ARM SUPPORT
4	24-0010-16		SHCS, 1/4-20 X 1 1/4"
5	21-8396		LIMIT ARM, STD STILES
6	24-4941-02	Zinc	FHMS, 1/4-20 X 1", PHIL, TRILOBE, ZN
7	24-0011-77	Zinc	FHCS, 7/16-14 X 1", ZN
8	24-0014-12		HHCS, 1/4-20 X 1 3/4"
9	24-0019-05		1/4" EXTERNAL STAR WASHER
10	14-10561-01	Clear	END CAP, PIVOT - TRAIL DOOR MILLED 204
	14-10561-02	Dark Bronze	END CAP, PIVOT - TRAIL DOOR 313
11	24-0011-130	Black Zinc	FHMS 10-32X1/2" PHIL TYP 23, UND, BLK ZN
	24-0011-131	Zinc	FHMS, 10-32X1/2", PHIL, TYP 23, UND, ZN
12	24-12002-10		CARRIER PVT ASSY NARROW STILE-UL PART
	24-12002-20		CARRIER PVT ASSY MED STILE-UL PART
	24-12002-30		CARRIER.PVT ASY - NRW STL-PNL <22.75"UL
	24-12002-40		CARRIER.PVT ASY - MD STL- PNL < 22.75"UL
13	24-0017-02		WASHER, 7/16 ID X 1 OD X .083 THK
14	14-5592-01	Smoke Seal Only/Gray	WEATHER STRIP - 9/16 IN VINYL FIN, GRAY
15	14-5592-02	Smoke Seal Only/Black	WEATHER STRIP - 9/16 IN VINYL FIN, BLACK
16	24-0016-51	Black Oxide	SHSS, 5/16-24 X 5/16" CUP PT, BLK OX
	24-0011-70	Zinc	FHMS, 1/4-20 X 7/16", PHIL, UND, ZN
17	24-0011-73	Black Oxide	FHMS, 1/4-20 X 7/16", PHIL, UND, BLK OX
18	24-0094-01		PHSMS, 10 X 1/2", PHIL, TYPE A
	24-9125-01	Smoke Seal Only/Clear	WEATHERING EXT, 204
19	24-9125-02	Smoke Seal Only/Dark Bronze	WEATHERING EXT, 313
	24-0013-03	Smoke Seal Only/Zinc	PHSMS, 6 X 1/2", PHIL, TEKS, ZN
20	24-0013-04	Smoke Seal Only/Black Zinc	PHSMS, 6 X 1/2", PHIL, TEKS, BLK ZN
	14-3933-01	Smoke Seal Only/Gray	WEATHERING GRAY VINYL 1 IN FIN
21	14-3933-02	Smoke Seal Only/Black	WEATHERING BLACK VINYL 1 IN FIN
	12-12958-01	Clear	KIT, ICU D/RECESSED HANDLE
22	12-12958-02	Dark Bronze	KIT, ICU D/RECESSED HANDLE
23	24-0011-96		FHMS, 1/4-20 X 3/4, PHIL
24	12-10722		BOTTOM PIVOT BRACKET ASSY
	14-5543-11	Clear	NOSE CASTER ASSY NARROW STILE
	14-5543-12	Dark Bronze	NOSE CASTER ASSY
	14-5543-21	Clear	NOSE CASTER ASSY MED. STILE
25	14-5543-22	Dark Bronze	NOSE CASTER ASSY
26	24-0021-21	Zinc	NUT, WHIZLOCK, 3/8-16, ZN
27	14-9225		BACKING PLATE, TIE ROD - DOOR ASSEMBLY

Slide Door			
Item	Part	Finish/Sizes/Notes	Description
28	24-9504		CLIP, MUNTIN BAR - RAIL .386 HOLE
29	14-3624	Zinc	THREADED ROD, 3/8"-16 - ZINC PLATED
30	24-9503		CLIP, MUNTIN BAR - RAIL .500 HOLE
31	14-9279		OFFSET TEE NUT, 3/8"-16
32	24-9502		CLIP, MUNTIN BAR - RAIL .261 HOLE
33	24-4941-02	Zinc	FHMS, 1/4-20 X 1", PHIL, TRILOBE, ZN
34	14-9511-04		PLUG, HOLE, .813 DIAMETER, BLK
35	11-14349		HOLD OPEN STRIKE JAMB HARNESS
36	11-14398		2-WAY SWITCH ASSEMBLY
37	14-12490		BUSHING, ELECTRICAL, .750 HOLE
38	24-0011-104	Black Oxide	FHMS, 10-32 X 1/2", UND, BLK OX
39	24-0016-05		SHSS, 8-32 X 5/16, CUP PT
	24-0017-04		WASHER, 1/4 ID X 9/16 OD X .049 THK, STL