



Automatic Entrance Systems

ELECTRICAL INSTALLATION MANUAL

SLIDERS

Typical Slider Wiring

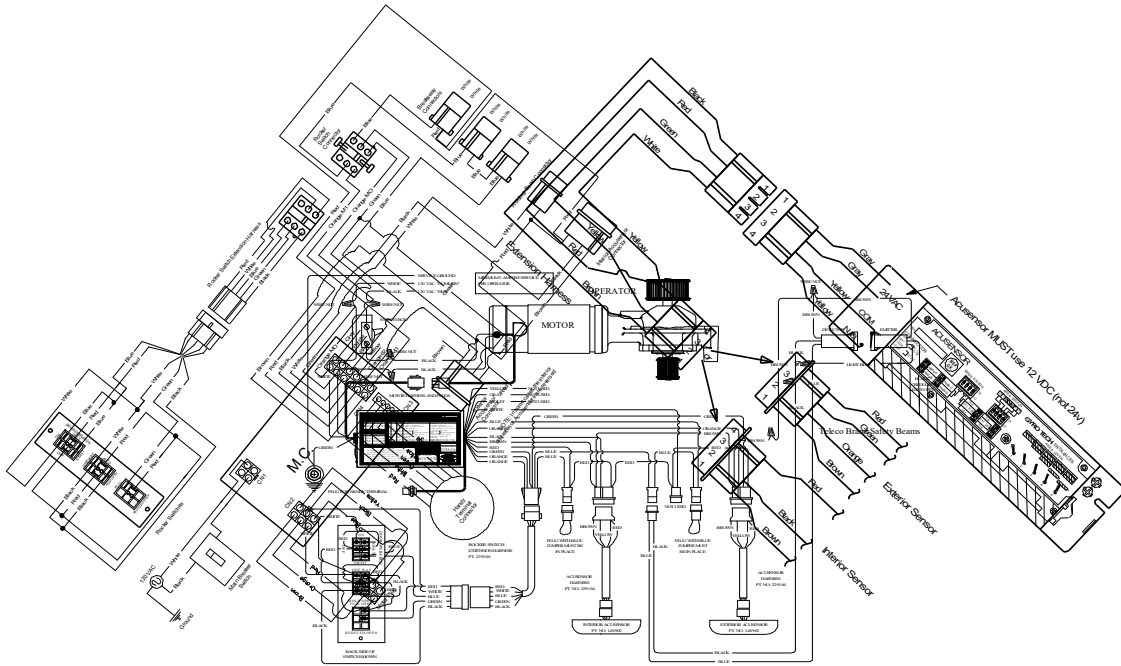

WARNING

Do not install, operate or service this product unless you have read and understand the Safety Practices, Warnings, Installation and Operating Instructions contained in this manual. Failure to do so may result in property damage, or bodily injury.

NABCO ENTRANCES INC.
 Phone: 877-622-2694 Fax: 888-679-3319
 Technical Assistance: 1-866-622-8325
<http://www.nabcoentrances.com>
 Email: CustomerService@NabcoEntrances.com

1510596 Revision 5-18-04

Table of Contents

Electrical Information	Page 3
Typical Slider Wiring	Page 4
Microprocessor Controller	Page 5-6
Dual Operator Wiring Diagrams	Page 7
Acusensor/Acumotion	Page 8
How Door Function Modes are Achieved via the Rocker Switches	Page 9
Holding Beams (Activation—Hold Open)	Page 10
Holding Beam (Breakout—Power Interrupt)	Page 11
Diagram for connecting push plates and or card readers for Night mode.	Page 12
Electric Locks—Fail Safe	Page 13
Electric Locks—Fail Secure	Page 14
Troubleshooting	Page 15-17

Electrical Information

WARNING

Disconnect all power to the junction box prior to making any electrical connections. Wiring must meet all local, state, federal or other governing agency codes. Failure to do so may result in serious personal or fatal injury.

Note: Since the Model 1175 Slider is predominantly wired at the factory the site installer/electrician has a relatively simple task.

1. Convenient electric service access holes have been provided in the slide header end caps and jamb tubes. An installer/electrician should route 120 VAC, single phase, 5 AMP (MINIMUM) power to the factory supplied and mounted junction box in the header.
2. The installer/electrician should connect one power hot lead (Black) to the power cut off switch mounted inside the junction box. Utilizing an appropriate wire nut, the installer/electrician should connect the common lead (White) to the loose common lead (White) found inside the junction box. The ground wire should be connected to the ground screw located in the back of the switch junction box.
3. Replace the junction box cover. The unit's power should now be activated through the building's electrical circuit breaker box. Proceed with performance set-up procedures outlined in the Microprocessor and Handy Terminal Manual p/n 159000

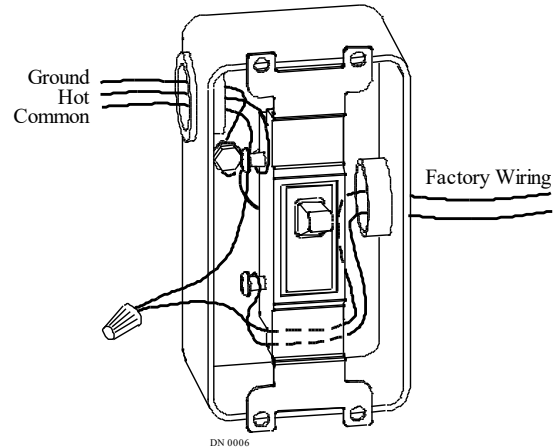

Wiring diagrams are included in the back of this manual, which reflect the typical primary and secondary circuits installed at the factory. The low voltage (12 VDC) Reed switch (panic break away) and Acusensor are easily connected on site using factory installed connector housings. The factory uses Underwriters Laboratories' (UL) recognized component wire, terminals and connector housings to manufacture the slider. Contact the Customer Service Department for assistance with special applications.

Microprocessor Controller

WARNING

Microprocessor controller contains HIGH VOLTAGE! Installation should be performed by qualified personnel only. Wiring must meet all local, state, federal or other governing agency codes. Failure to do so may result in serious personal or fatal injury.

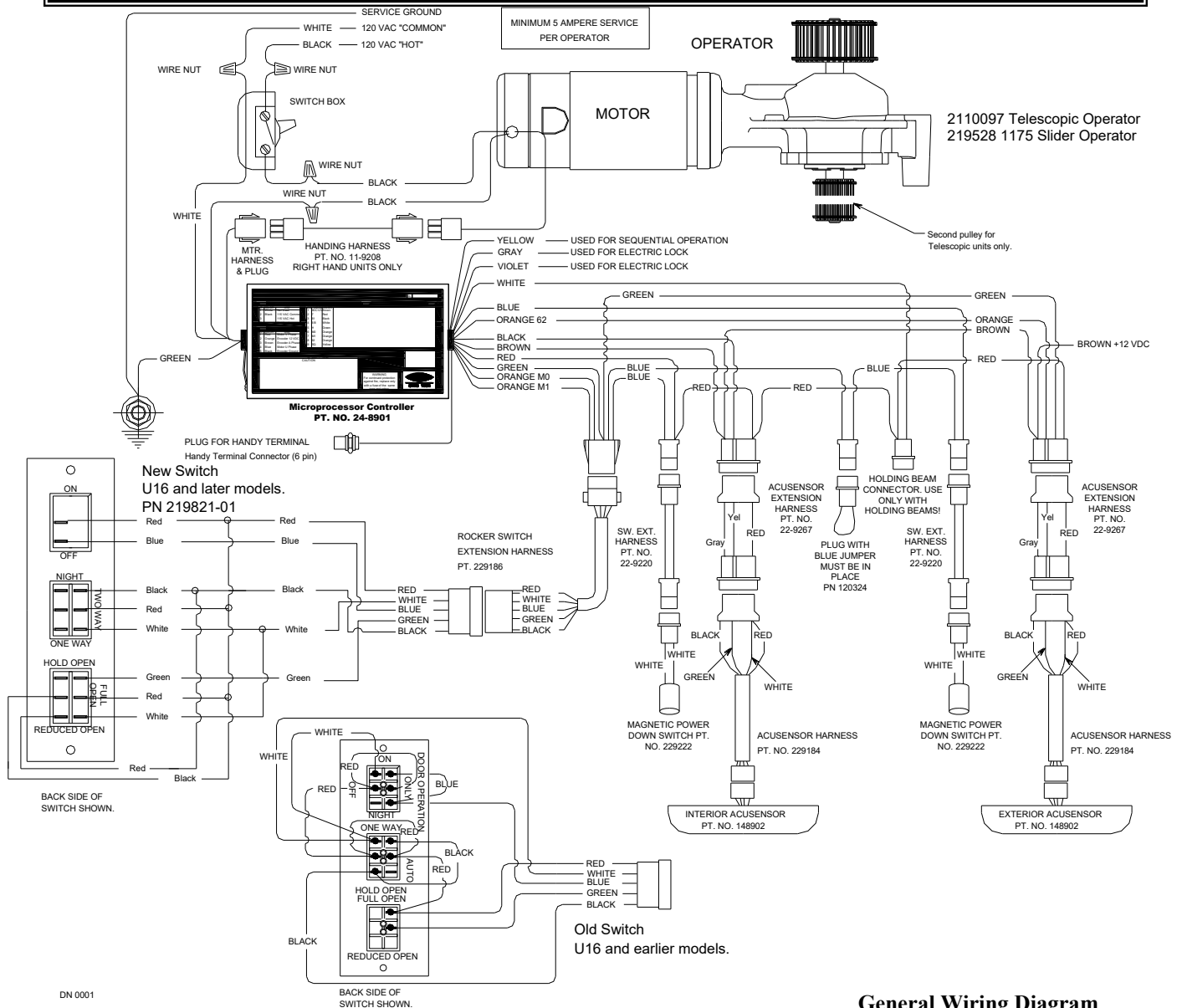

General Wiring Diagram

Microprocessor Controller

Slider Schematic Wiring Diagram - U04 and Higher Microprocessor

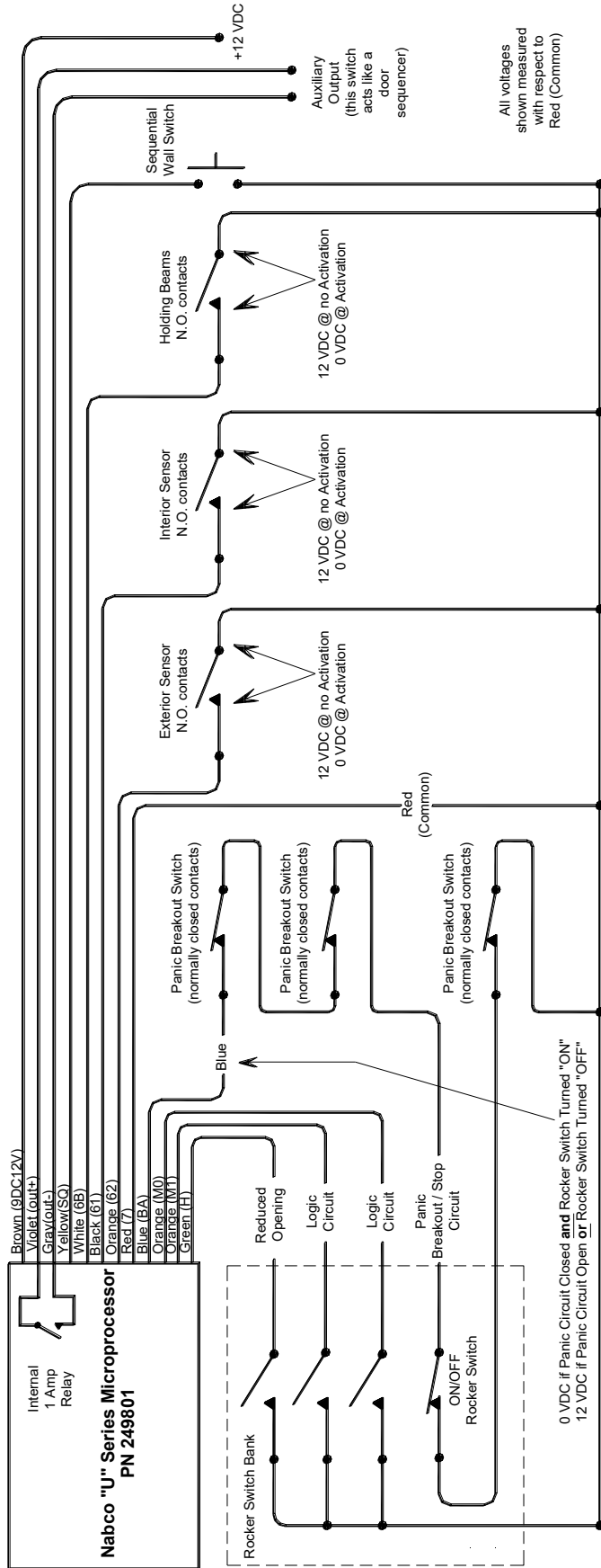

DWG#10

By alternately switching the two MO & MI (orange wires) on the microprocessor harness to RED (common) the various door modes such as HOLD OPEN mode, EXIT mode, NIGHT mode etc. are achieved. (Off = not switched to common On = switched to common)
Blue (BA) wire must remain tied to Red (Common) for door to function.

Refer to Page 9 for more information

The Microprocessor controller has been designed to control the numerous operating characteristics of the slide door system including speed, recycling and door opening width. It will need to be programmed after the installation is complete. (See the Microprocessor Manual p/n 159000 for more details).

CAUTION:
 Read and understand the Microprocessor Manual p/n 159000 before attempting to power-up the door. Failure to do so may result in damage to the door and/or injury to the installer and will nullify all warranties.

**Microprocessor Main
 Harness Diagram**

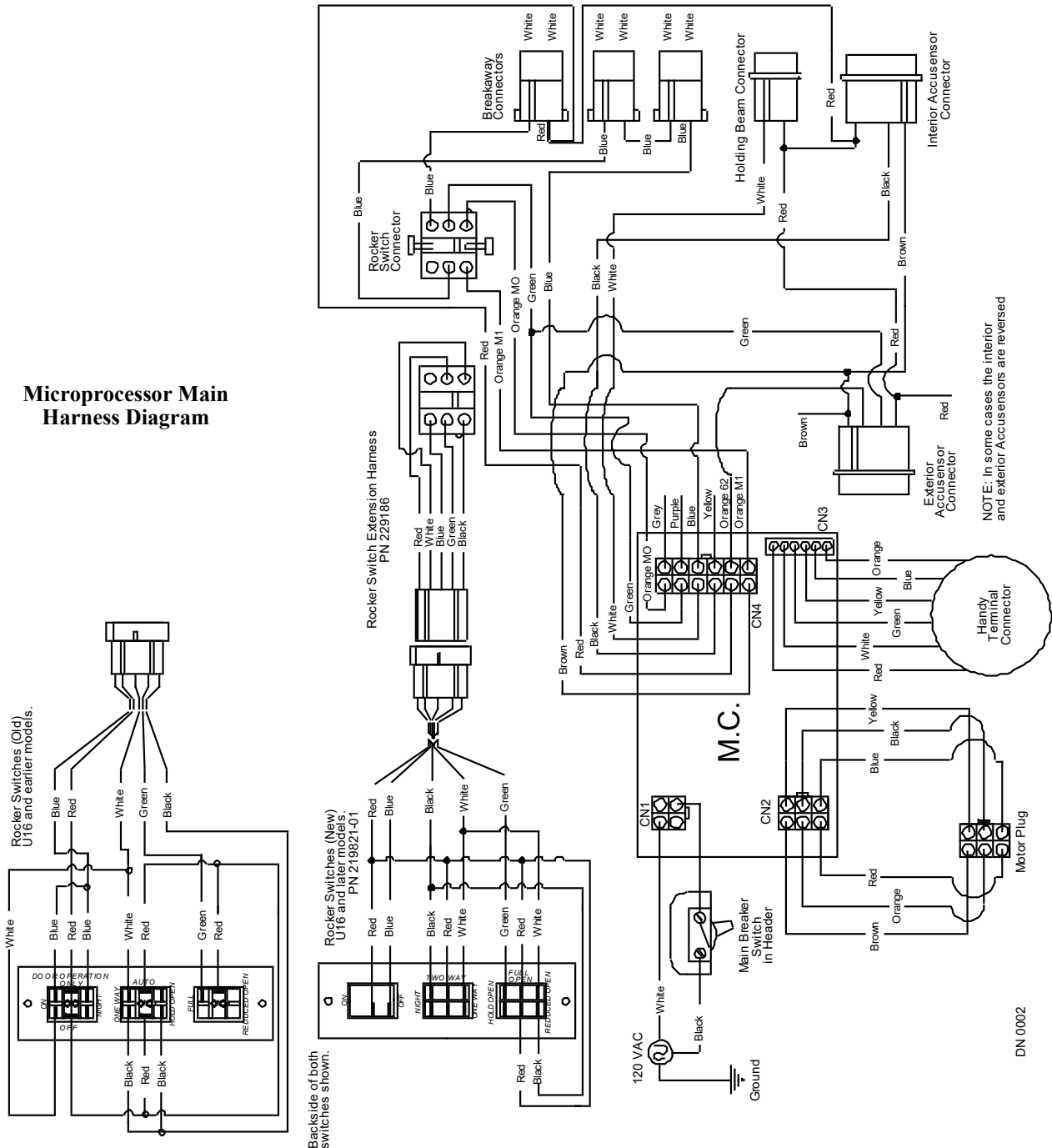

Dual Operator Wiring Diagram

DUAL OPERATOR WIRING DIAGRAM

Plug Rocker Switch #219821-01 into MC Harness #218901 at C Receptacle of #215901 harness.

If this is not followed, Breakout will not function and the Breakout Switches #229183 may weld shut and need to be replaced.

A door stop is needed at the center of the header to stop the doors independently.

Plug both Breakout Switches #229222 into MC Harness #218901 at D Receptacle of Harness #215901.

If this is not followed, Breakout will not function properly.

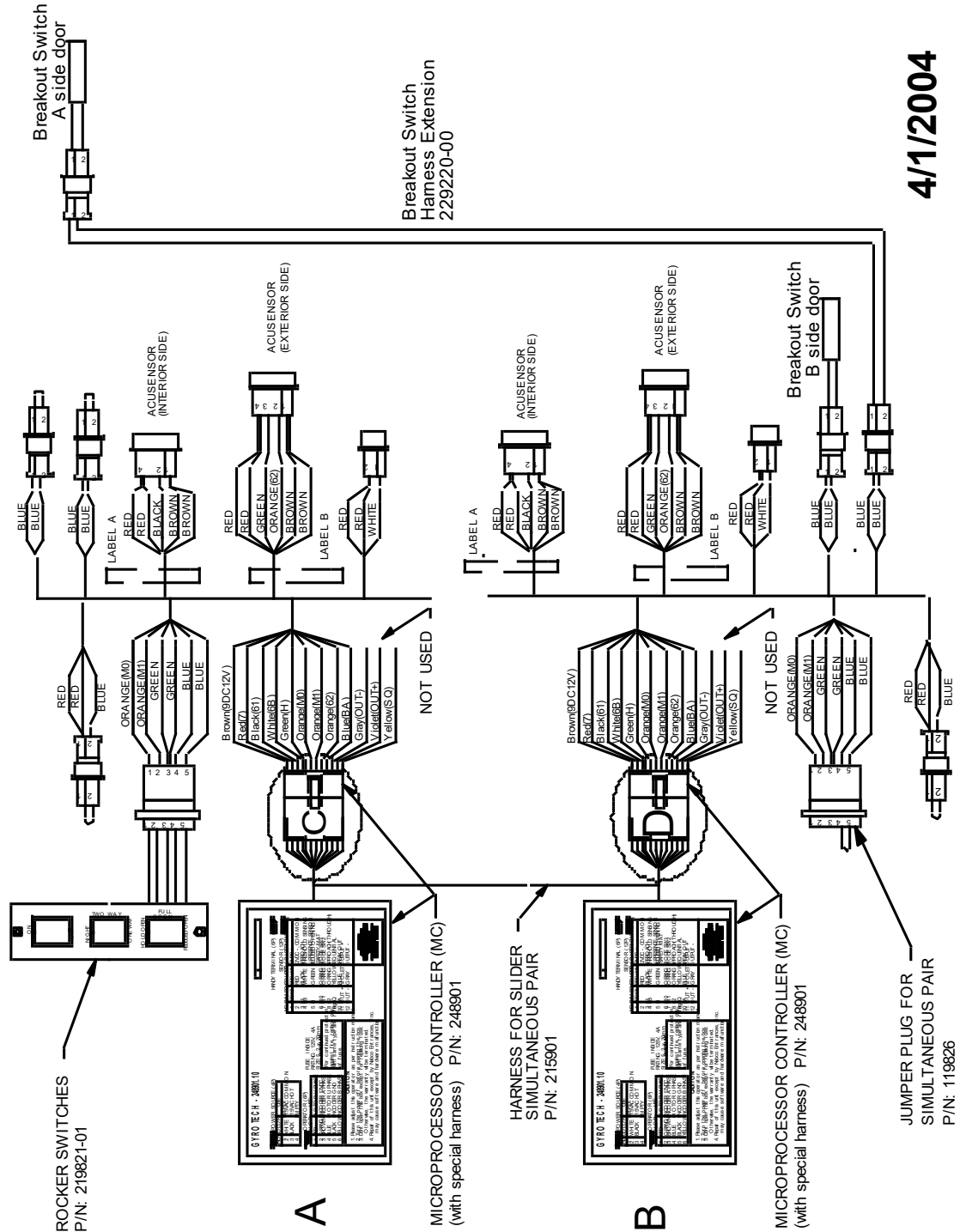

Breakout Switch
Harness Extension
229222-00

4/1/2004

DN0071

ACUSENSOR/ACUMOTION

The header is wired from the factory so that the activation circuitry on the exterior sensor is turned off in One Way Traffic Mode (the safety circuitry remains active and can not be turned off). The exterior sensor is located on the side of the header in the direction of panic or panel breakout. This can easily be reversed in the field by swapping the connectors where each sensor plugs into the main harness.

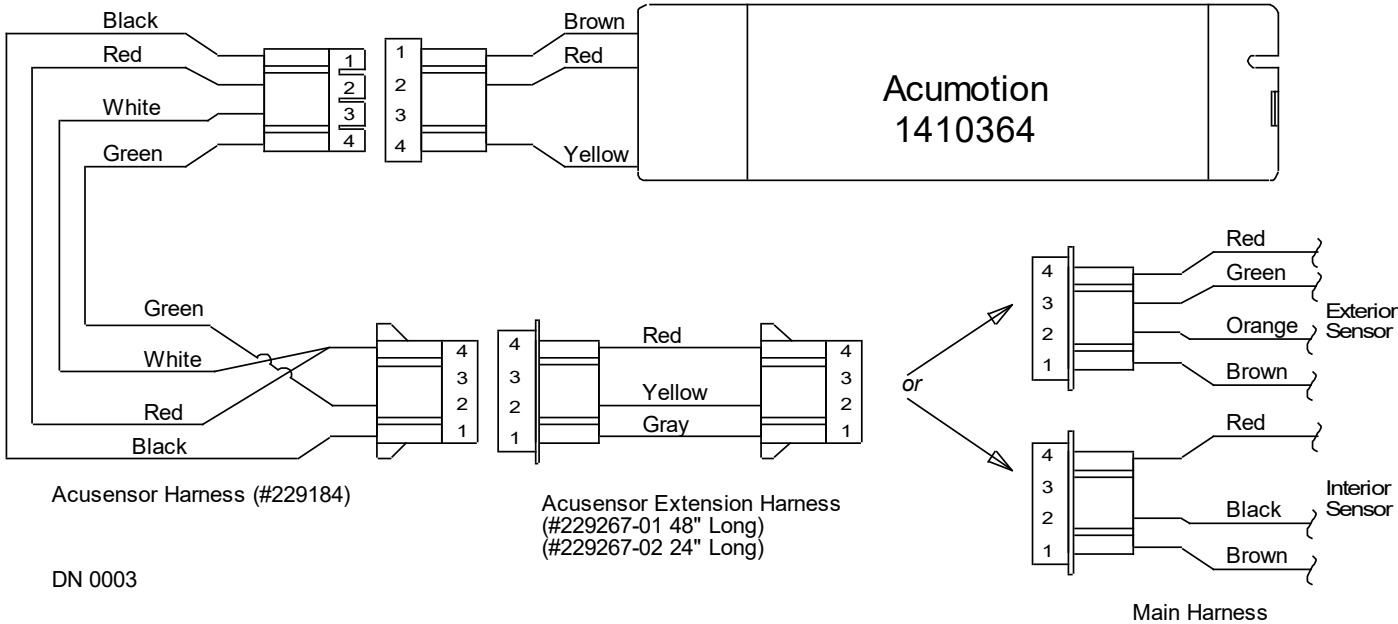
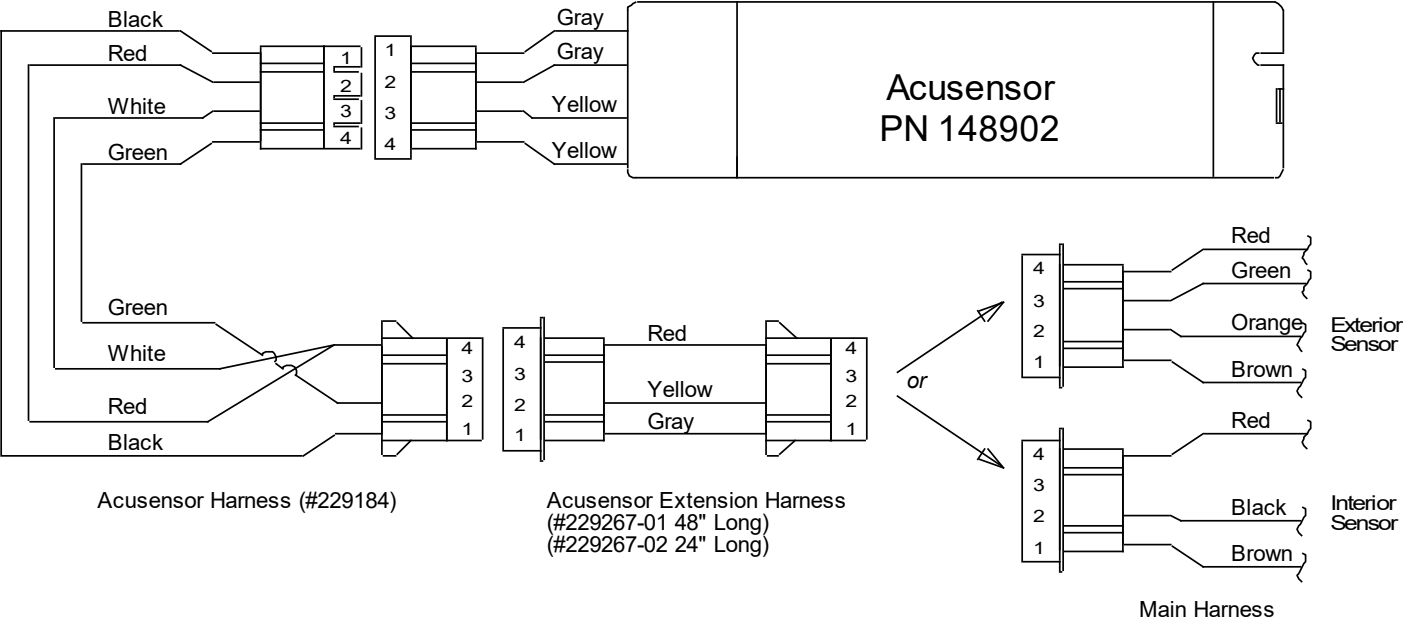

DN 0003

How Door Function Modes are Achieved via the Rocker Switches

By alternately switching the two MO & M1 (orange wires) on the microprocessor harness to RED (common) the various door modes such as HOLD OPEN mode, EXIT mode, NIGHT mode etc. are achieved. Refer to the tables below.

(Off = not switched to common On = switched to common)

<u>MO</u>	<u>M1</u>	<u>Results</u>
OFF	OFF	Auto Mode. Both sensor signals are available Electric Lock is always unlocked.
OFF	ON	Night Mode. None of the sensor signals will be accepted. Sensors will provide threshold safety and electric lock is always locked. Activation must occur by means of an exterior activation device such as a card reader or key switch.
ON	ON	Hold Open Mode. The door keeps the full open point, not affected by sensors. Electric Lock is always unlocked.
ON	OFF	One Way Traffic. The interior sensor activates the door; the exterior sensor provides threshold safety. Electric Lock is locked until an interior activation is received

The table at right summarizes the functions as outlined above:

MODE SWITCH TABLE		
<u>MO</u>	<u>M1</u>	<u>Mode</u>
OFF	OFF	Automatic Mode
OFF	ON	Night Mode
ON	ON	Hold Open Mode
ON	OFF	One Way Mode

Holding Beams (Activation—Hold Open)

The Holding Beam is a factory-installed unit consisting of an emitter, detector and control box. They are flush mounted in door frames and/or jamb tubes, facing each other. A pulsed, infrared light beam is continuously transmitted across the door opening. Interruption of the beam by breaking out a door panel will interrupt the blue wire power down loop. This will cause the system to stop operating until the door panel is repositioned and latched.

Optex OA-10C Beams on a GT-1175 Wiring Diagram for Holding Beams (U04 and Higher)

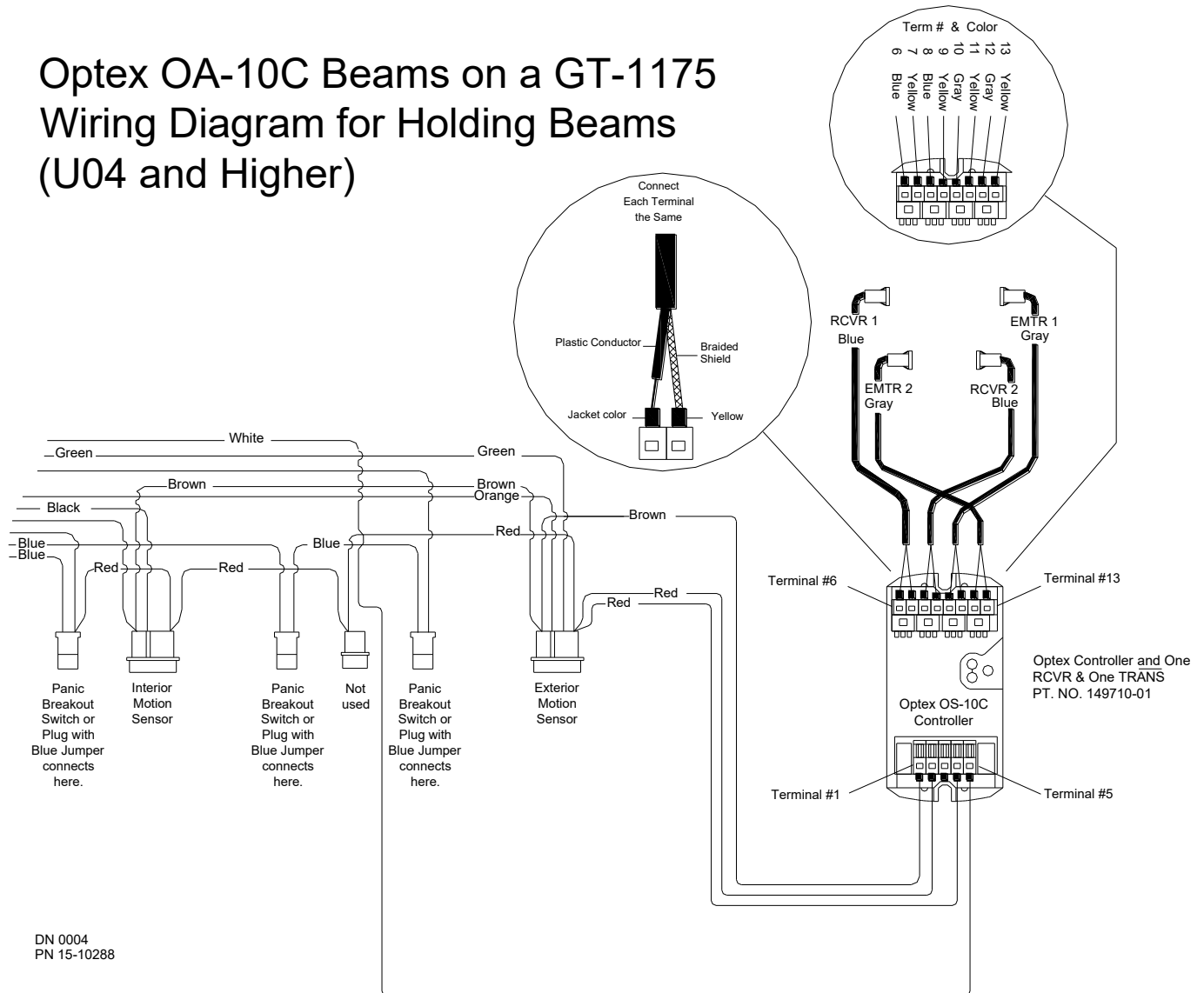

Holding Beam (Breakout—Power Interrupt)

The Holding Beam is a factory-installed unit consisting of an emitter, detector and control box. They are flush mounted in door frames and/or jamb tubes, facing each other. A pulsed, infrared light beam is continuously transmitted across the door opening. Interruption of the beam by breaking out a door panel will interrupt the blue wire power down loop. This will cause the system to stop operating until the door panel is repositioned and latched.

G. Electrical Information

**Optex OA-10C Beams on a GT-1175
Wiring Diagram for Breakout Beams
(U04 and Higher)**

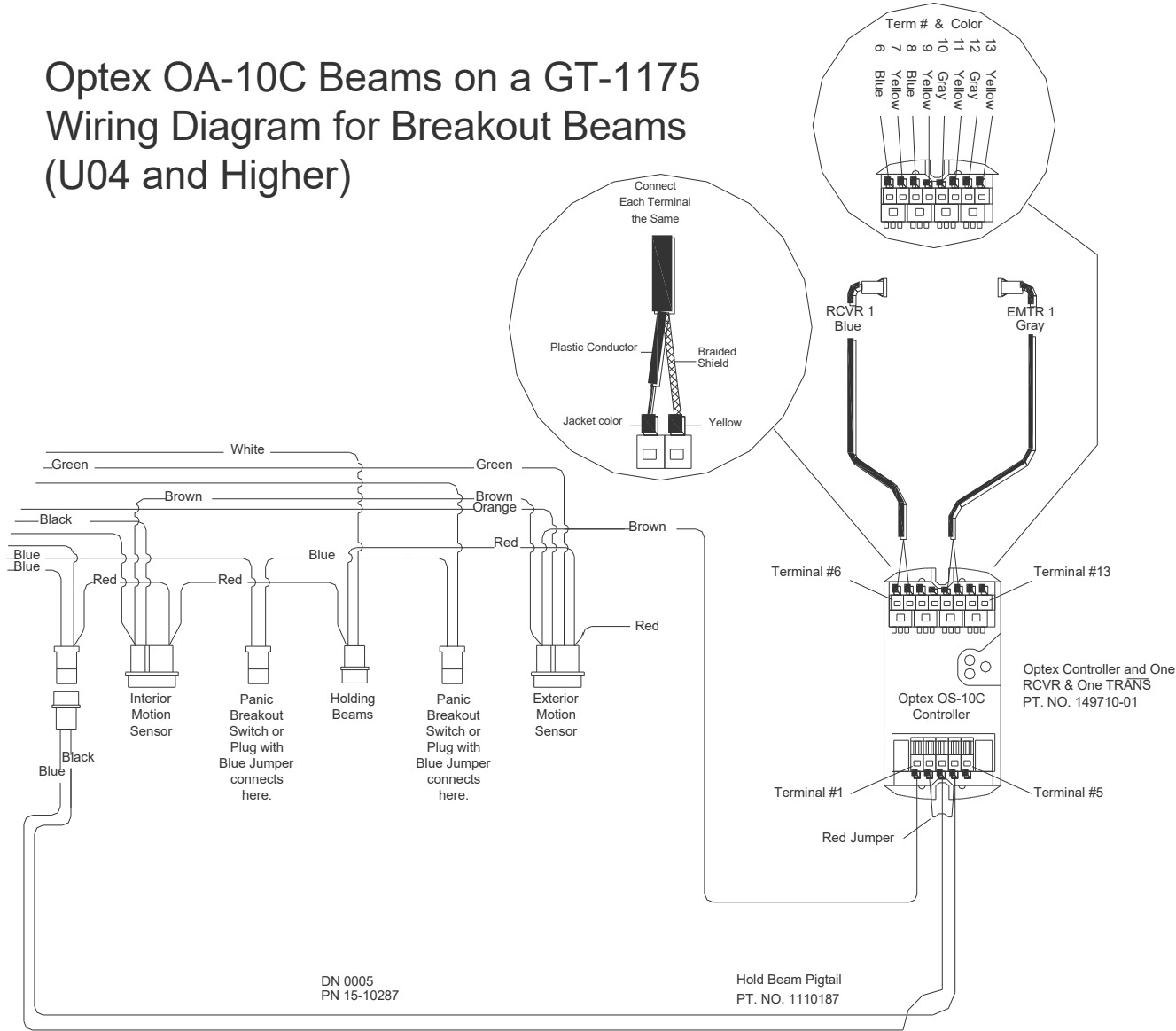
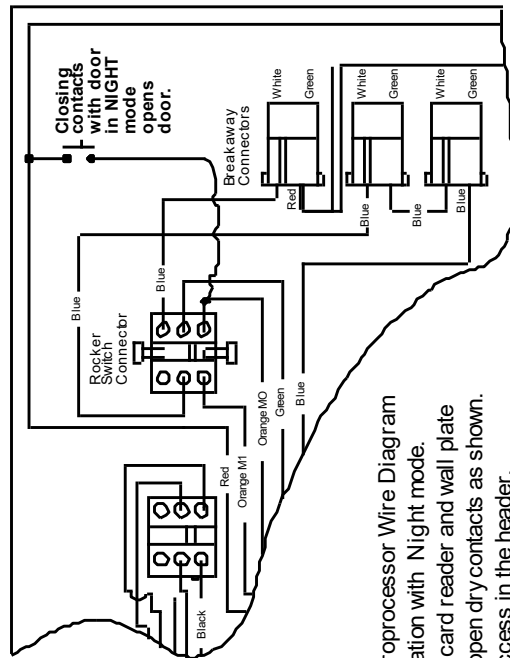
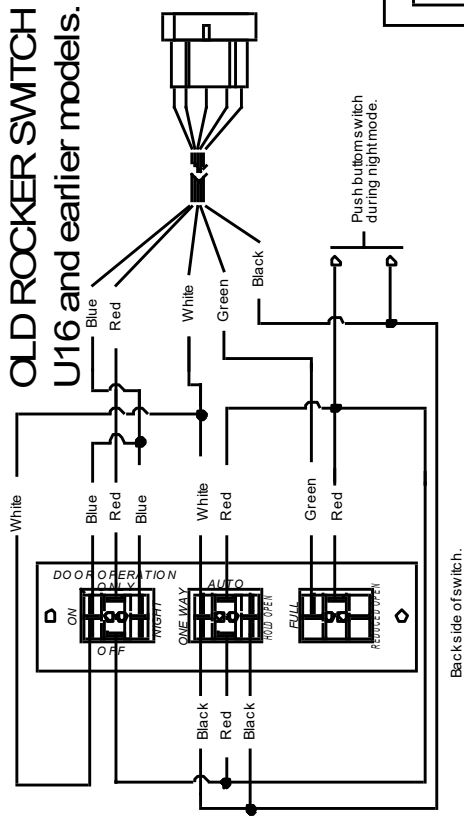
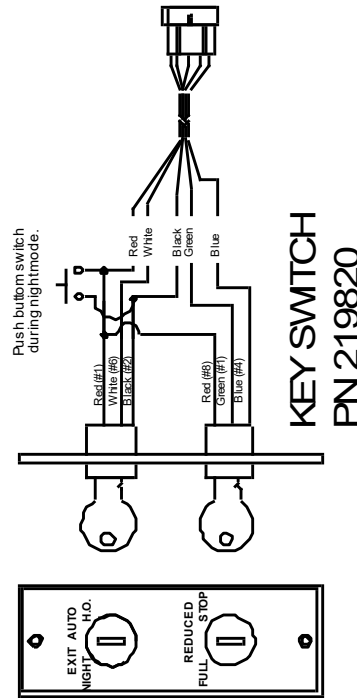
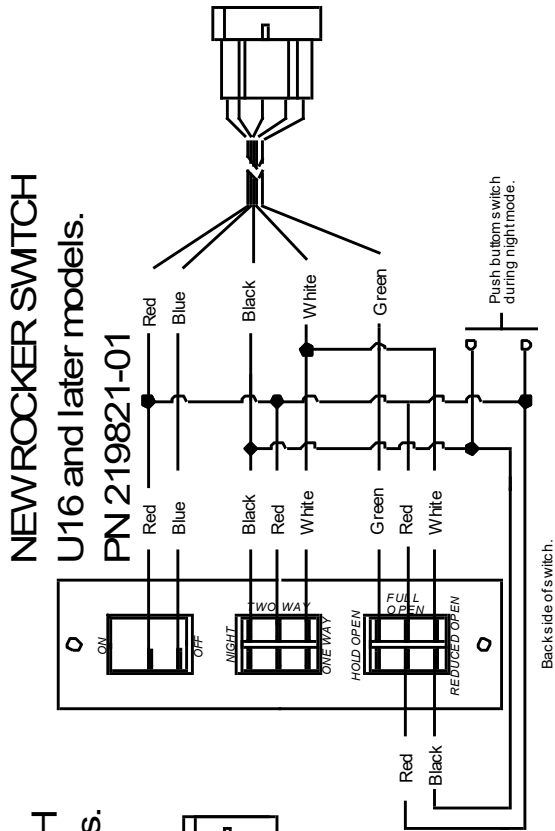

Diagram for connecting push plates and or card readers for Night mode.

Attach the normally open contacts across the red and black wire on either the rocker or key switches.



1175 Microprocessor Wire Diagram
Activation with Night mode.
Connect card reader and wall plate normally open dry contacts as shown.
Access in the header.

DN0007

Electric Locks—Fail Safe

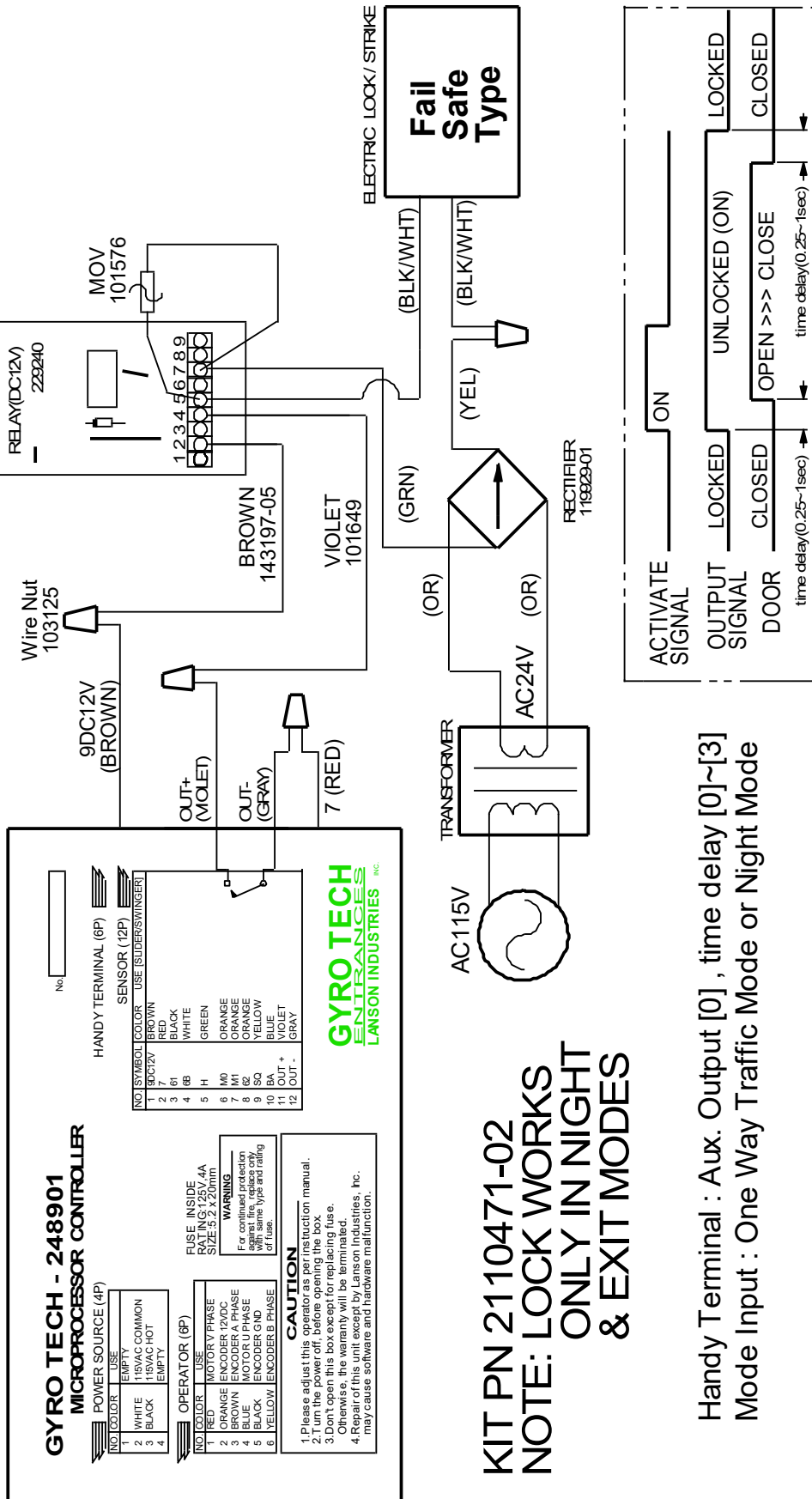

KIT PN 2110471-02
NOTE: LOCK WORKS ONLY IN NIGHT & EXIT MODES

Handy Terminal : Aux. Output [0], time delay [0]~[3]
 Mode Input : One Way Traffic Mode or Night Mode

DN 0008

Electric Locks—Fail Secure

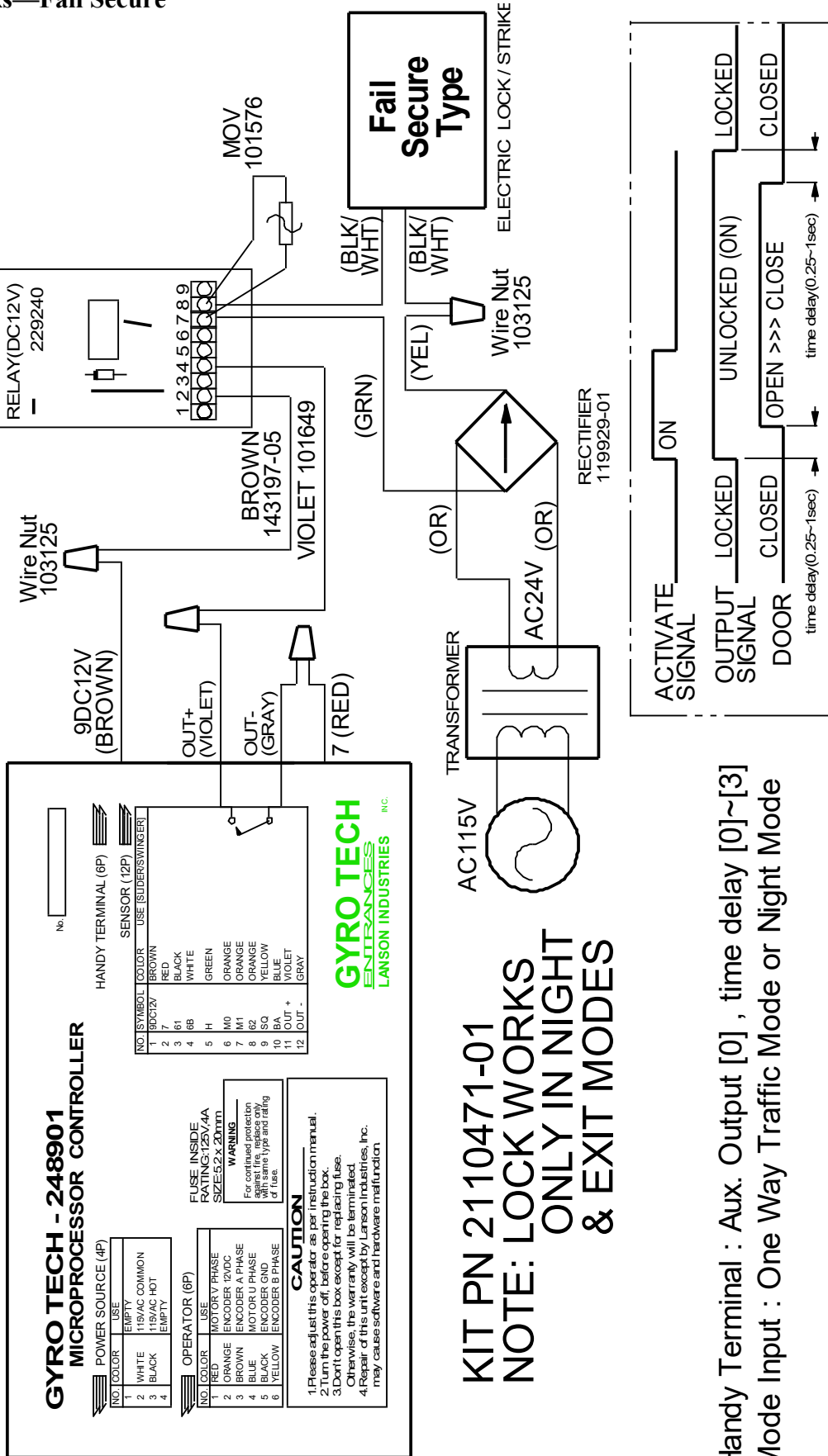

KIT PN 2110471-01
NOTE: LOCK WORKS ONLY IN NIGHT & EXIT MODES

Handy Terminal : Aux. Output [0] , time delay [0]~[3]
 Mode Input : One Way Traffic Mode or Night Mode

DN 0009

Trouble Shooting

REVISES	DATE
ERN 884	6-11-03

1 LABEL: DOOR POSITION TEST HARNESS FOR GT 300/400/500/710 MAGNUM CONTROL

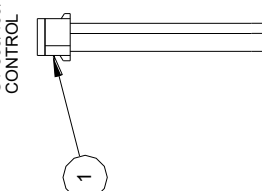

2 LABEL: DOOR POSITION TEST HARNESS FOR GT 1100

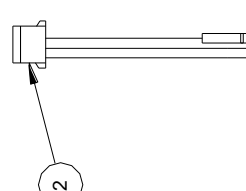

3 LABEL: TEST HARNESS FOR GT 300/400/500 ANALOG CONTROL

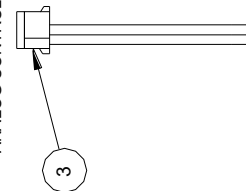

4 LABEL: MICROPROCESSOR TEST PLUG

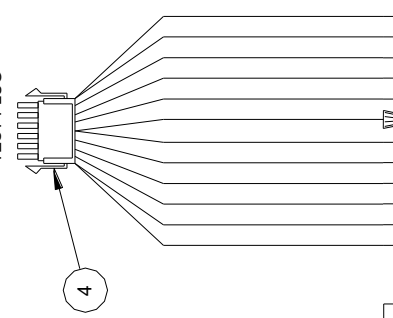

5 LABEL: MICROPROCESSOR SWITCH JUMPER PLUG

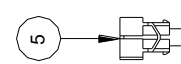

6 LABEL: PANIC SWITCH BYPASS PLUG

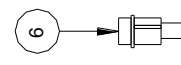

7 LABEL: MICROPROCESSOR JUMPER PLUG

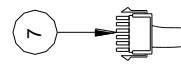

8

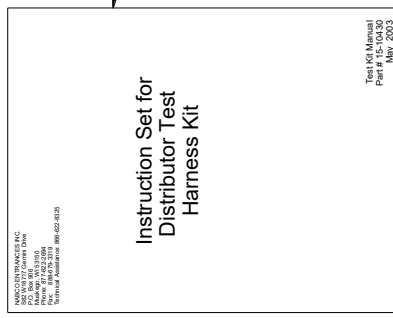

Instruction Set for Distributor Test Harness Kit

Test Kit Manual
Part # 15-10430
May 2003

ITEM	QTY	PART NO.	DESCRIPTION
8	1	1510430	Instruction Set for Distributor Test Harness Kit
7	1	115941	Microprocessor Jumper Plug
6	2	1210324	Panic Switch Bypass Plug
5	1	119826	Microprocessor Switch Jumper Plug
4	1	1110429	Microprocessor Test Plug
3	1	1110427	Test Harness for GT 300/400/500 Analog Control
2	1	1110428	Test Harness for GT 1100
1	1	1110426	Door Position Harness for Magnum Control

DATE:	4-21-03
SCALE:	None
DRAWN BY:	MB
CHECKED BY:	MB
TOLERANCES UNLESS NOTED:	
FRACTIONAL:	$\frac{1}{16}$
DECIMAL:	0.015
XXX:	0.005
ANGLE:	1/2
SHEET #:	1 OF 1

PART NAME:	Distributor Test Harness Kit
MATERIAL:	
SPECIFICATIONS:	
Drawing No.	1110431
Part No.	1110431



Troubleshooting

1. ***Acusensor does not seem to reach out far enough***
 - a) Move the area lever on the side of the Acusensor to a higher number.
 - b) Increase the opening speed on the door with the Handy Terminal.
 - c) If desired, replace Acusensor with Acumotion for greater detection range.
2. ***Acusensor is not seeing people accessing the door from the side.***
 - a) Turn on more of the area switches on the front of the Acusensor.
 - b) Door is set to One Way Traffic mode and sensor is switched out. Set door to Auto mode.
3. ***When the doors are panicked open, the system does not shut down.***
 - a) Check the wiring of the power down switch in the fixed panel or bottom of header. (Full Open Units.) Blue (BA) circuit must go open for system to shut down.
 - b) Check the wiring of the breakout beam circuit. (Surface Applied Units.) Blue (BA) circuit must go open for system to shut down.
4. ***Doors do not move when power is applied or Handy Terminal connected.***
 - a) Confirm the swing panel is closed completely.
 - b) Confirm Blue (BA) circuit is not open. Zero VDC between Red and Blue on microprocessor harness for correct operation. If 12VDC circuit is open.
 - b) Check the power down magnet in the top rail of the swing panel is installed and aligned with the magnetic power down switch in the bottom of the header.
 - c) Confirm rocker is switch is set to ON not OFF.
5. ***The cover on the Acusensor will not snap on.***
 - a) Install thin washers to space the Acusensor off from the header and provide clearance for the cover.
6. ***Doors move very slowly when the Handy Terminal is connected. (Only happens after “Stroke Cycle” initiated.)***
 - a) This is normal. It is “learning” the door stroke.
 - b) After learning the stroke, the Handy Terminal will prompt you with options
7. ***The doors do not open completely.***
 - a) Look for obstructions in the track as well as inside the header. Check to make sure that the belt clips are not hitting something.
 - b) On Full Open units be sure that the interlock clips are adjusted properly.
 - c) Check for any racking in the door.
 - b) Check that the mode switch on the panel is not in “Reduced Opening” mode.
 - c) Use the Handy Terminal and reinitialize the system.
8. ***I want to eliminate all outside switches and sensors and test the system with the Handy Terminal.***
 - a) Disconnect the 12-pin connector from inside the microprocessor and install the special connector jumper tool p/n 115941 into its place.
 - b) The system will consist of only the motor, operator and control box (Microprocessor). The Handy Terminal will be the only means of operating the door.

Troubleshooting

9. *I want to reset the system back to the factory settings.*

- a) Plug in Hand Terminal and wait for the door to close.
- b) At “Swing/Slide/Stroke?” enter YES.
- c) At “Swing Door Y or N?” enter YES (even though you have a slide door).
- d) Door will try to initialize as a swing door and reset the settings.
- e) At “Swing/Slide/Stroke?” enter YES.
- f) At “Swing Door Y or N?” enter NO.
- g) The system will now initialize as a slide door to the factory settings.
- h) You must set the door stroke from the Handy Terminal from the prompts at this point.

10. *Door does not run unless holding beam is interrupted.*

- a) The holding beam connector (it has a red and white wire in it) in the main harness may be inadvertently plugged into one of the “Power Down” (blue wires) plugs. Any vacant “Power Down” plugs should have a blue jumper installed.

For technical assistance call: 866-622-8325
or engineering at: 877-622-2694