



This document is meant to serve as a Quick Set-Up and Parts Guide only.
Installation manuals referenced below should be downloaded and reviewed for complete installation instructions.

*Associated Manuals Part Numbers: Opus Control Wiring and Programming QSPG (P/N C-00139)
GT710, 8710 Low Energy Hardware Installation Manual (P/N C-00085)
Low Energy Sliding Door Owner's Manual (P/N C-00125) for Decal Installation
NABCO Price Book (P/N 16-9244-30) for Sensors, Switches, and Accessories*

WARNING

- Turn OFF all power to the Automatic Door if a Safety System is not working.
- Instruct the Owner to keep all power turned OFF until corrective action can be achieved by a NABCO trained technician. Failure to follow these practices may result in serious consequences.
- NEVER leave a Door operating without all Safety detection systems operational.

Table of Contents

SECTION 1: TO THE INSTALLER 2

SECTION 2: INSTALL THE HEADER. 2

SECTION 3: 120 VAC GENERAL WIRING 5

SECTION 4: INSTALL THE OUTSWING ARM SHOE ASSEMBLY. 6

SECTION 5: INSTALL THE INSWING ARM TRACK 8

SECTION 6: INSTALL THE SECOND HALF OF SWING ARM 11

SECTION 7: INSTALL THE ARM STOP 13

SECTION 8: ADJUSTMENTS 13

SECTION 9: TROUBLESHOOTING 15

SERVICE PARTS: GT 710 LOW ENERGY HEADER 16

SERVICE PARTS: GT 8710 LOW ENERGY HEADER 18

SERVICE PARTS: SWING ARM ASSEMBLIES 20

SECTION 1: TO THE INSTALLER

The purpose of this manual is to familiarize the installer and purchaser with the proper installation and operation of this system. It is essential that this equipment be properly installed and operational before the door is used by the public. It is the installer's responsibility to inspect the operation of the entrance system to be sure it complies with any applicable standards. In the United States, ANSI Standard 156.19; ANSI Standard 117.1 and the Low Energy Operator section of ADA Standard covers the GT 710/8710 Swing Door Low Energy System. Other local standards or codes may apply. Use them in addition to the ANSI standard. Low Energy Swing door Units are listed with the Underwriters Laboratory and is identified as such on the label. The owner should determine the door is operating properly and should immediately call for service if there is any malfunction. All installation changes and adjustments must be made by qualified, NABCO trained technicians.

GT 710/8710 Swing Door Low Energy Units are designed to be installed onto the top surface of the Door Frame. The Operator is controlled by the Opus Control that offers many features to accommodate most installation options.

SECTION 2: INSTALL THE HEADER

2.1 Before Installing the Header

1. Open the Inswing door 90 degrees.
 - a. Outswing doors do not need to be measured.
2. Measure between the wall and the outside face of the Swing Door.
 - a. There must be a 2 inch minimum gap.
 - b. If there is less than a 2 inch gap, please call Customer Service at (877) 622-2694.

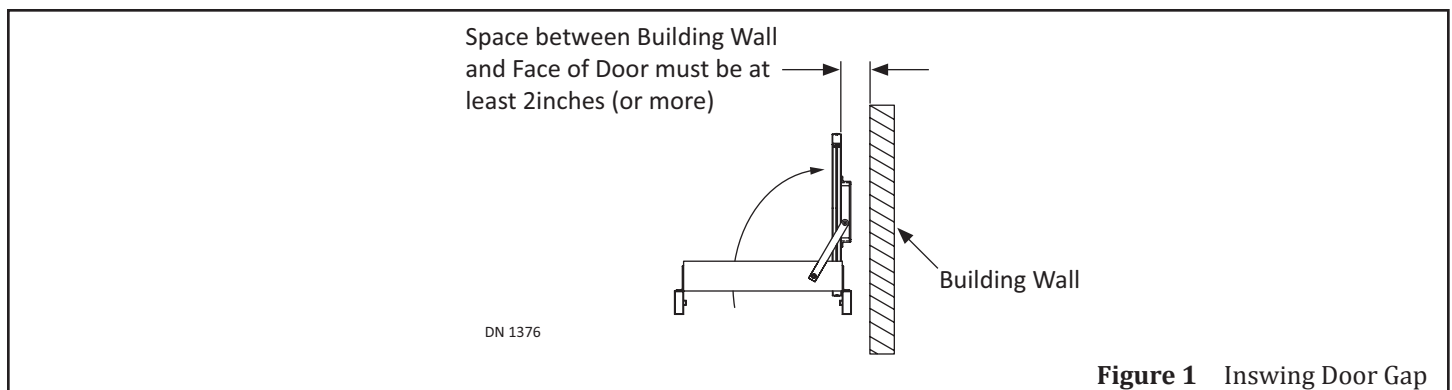

2.2 Prepare the Header

Note: It may be necessary to remove the Motor/Operator from the Header to reduce weight, while positioning the Header onto the Door Frame.

1. Remove the Header Cover. Remove boxes and/or parts bags from inside Header. Set aside.

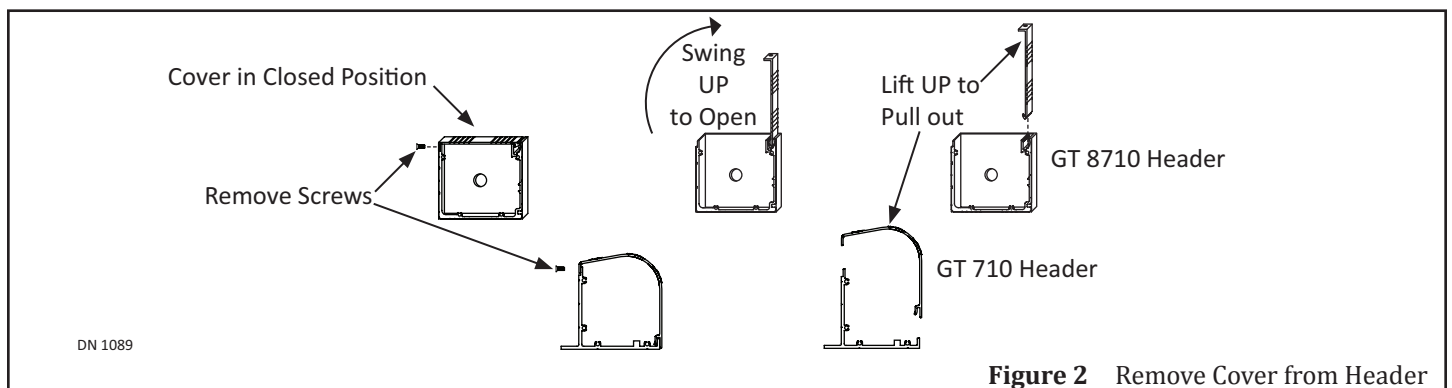

2.2.1 Drill Holes in Header (GT8710)

FOR GT710 UNITS SKIP TO SUBSECTION 2.3

Note: Protect Header Components from metal chips when drilling.

1. Go to the Strike side of Header. Drill one 7/8 inch hole through the Header to allow all wiring to be drawn inside.
 - a. The GT-8710 Header can be ordered with a Knockout hole located at either end of the Header. For details, please call Customer Service at 1-888-679-3319.
 - b. For Simultaneous Pair Swing Doors, it is acceptable to drill a 7/8 inch hole in the back of the header.
2. Go to the back wall inside Header on the Pivot side.
3. Measure 1 inch from the End Cap of Header towards the center. Mark a Vertical Line.
4. Measure at least 1/2 inch from the bottom of Header towards the top. Mark a Horizontal Line across the Vertical line. This is the center of the first screw hole. Drill 1/4 inch screw hole.
5. Mark (1) more Horizontal line across the Vertical line directly above the first screw hole. This is the center of the second screw hole. Drill 1/4 inch screw hole. Go to the Strike side of Header. Repeat steps 3 thru 5.

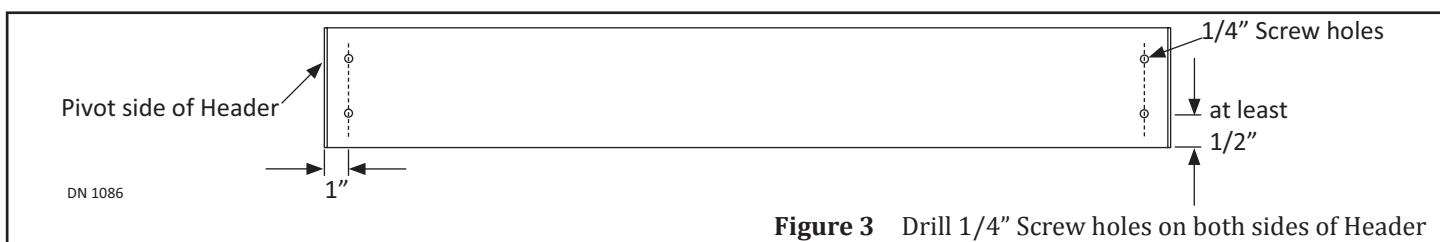

Figure 3 Drill 1/4" Screw holes on both sides of Header

2.3 Prepare the Door Frame

Note: The following instructions are for typical Metal Doors and Frame Profile. It is recommended to use lag bolts.

Note: If the Door Frame is not properly reinforced nor anchored to the building surface, and/or is hollow, reinforce the Door Frame with 1/4-20 blind rivnuts (not provided by NABCO).

Note: If the Door Frame is not Metal, ensure the Door Frame being used is of equal strength.

Note: Spindle location is very important when measuring from the Door Jamb.

1. Go to the Pivot Side of Swing door.
2. Measure up from the top of door to the face of Top door frame:
 - ▶ GT 710: 1/8 inch
 - ▶ GT 8710: 1-1/8 inch
3. Mark a Horizontal Line on the face of Top door frame, at both ends.

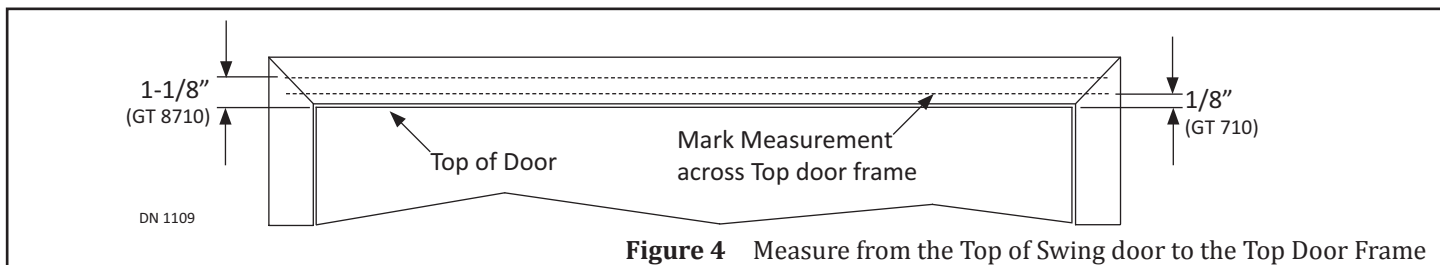

Figure 4 Measure from the Top of Swing door to the Top Door Frame

4. Lift the Header up against the Top door frame until the bottom edge of Header is butted up against the Horizontal Line, at both ends.
5. To ensure proper operation of the Swing Arm:
 - ▶ For a Door Jamb that is 1-3/4 inches wide, position the Pivot side of Header so it is flush to the outside edge of the Pivot Door Jamb.
 - ▶ For a Door Jamb that is wider than 1-3/4 inches, measure from the inner edge of the Pivot Door Jamb to the center. Mark a vertical line at the 1-3/4 inch measurement. The Pivot side of Header must butt against the 1-3/4 inch mark.

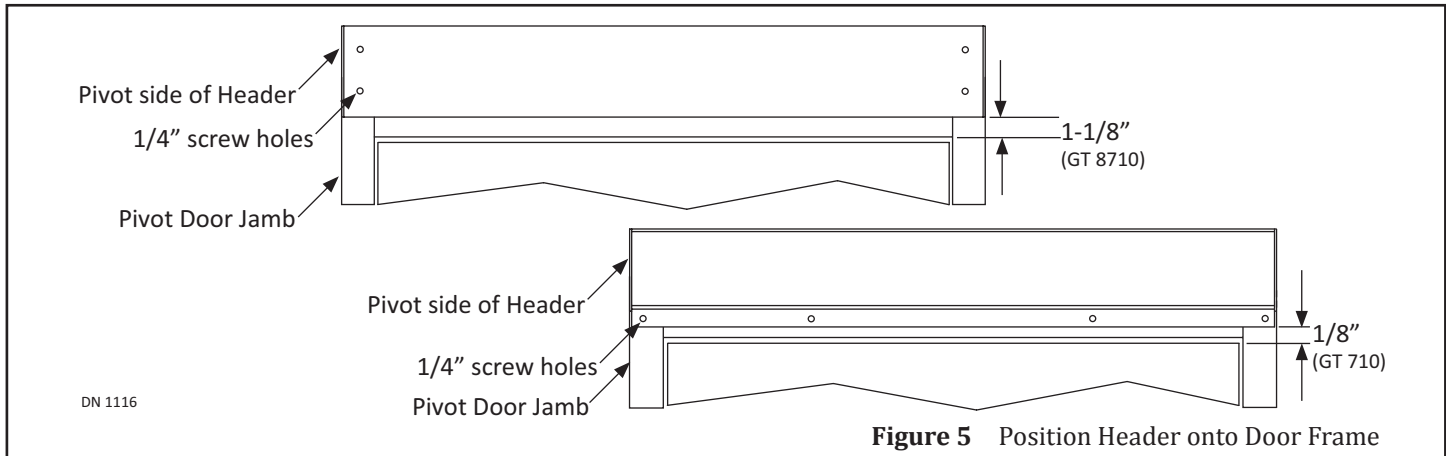

Figure 5 Position Header onto Door Frame

6. Ensure the Header is square and level. Use the Header as a template to mark screw holes onto the face of the door frame.
7. Remove the Header. Drill screw holes at each mark.

2.4 Install the Shim (Metal Door Frames)

FOR UNITS NOT INSTALLING A SHIM SKIP TO SUBSECTION 2.5

1. Butt the Header up against the Horizontal line. Line up the screw holes and then ensure the Header is square and level.
2. Go to the top of Header. Mark a horizontal line along the top edge of Header onto the wall.
3. Measure the depth between the back side of the Header and the wall.
 - a. Write that measurement down and label it #1.
4. Measure the distance between the top of door frame and the horizontal line that was just drawn at the top of Header.
 - a. Write that measurement down and label it #2.

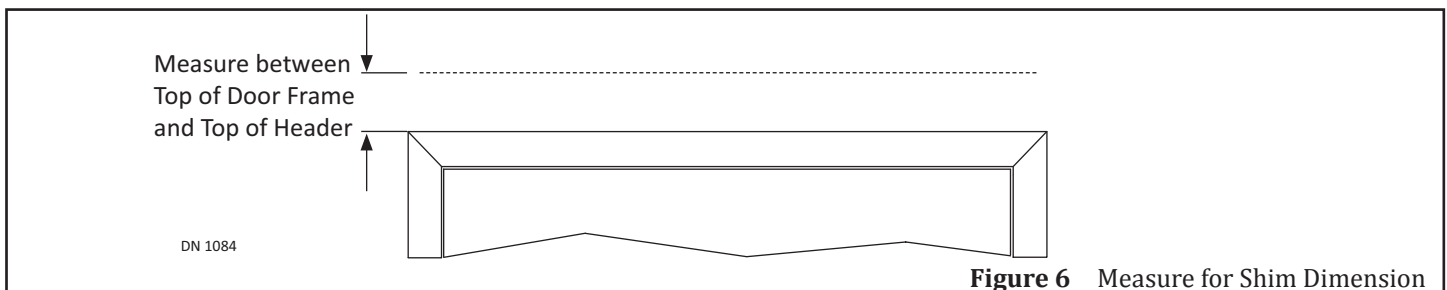

Figure 6 Measure for Shim Dimension

5. Obtain (1) Shim to be the same depth as measurement #1; no higher than measurement #2; and about the same width as the Header.
6. Secure the Shim to stud(s).
 - a. It is recommended to use Lag Bolts.

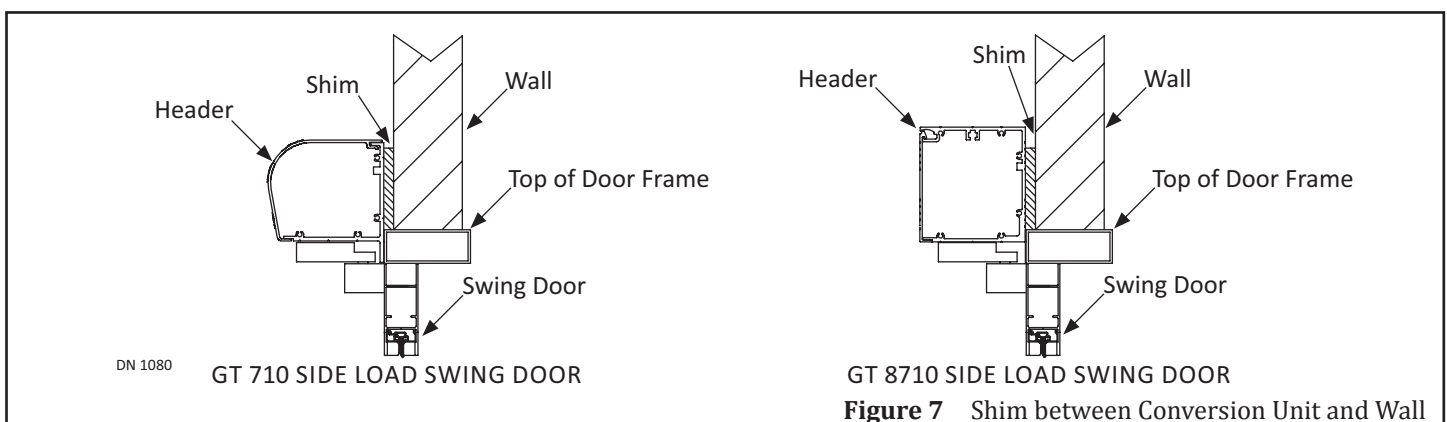

Figure 7 Shim between Conversion Unit and Wall

2.5 Secure the Header to the Door Frame

1. Lift up the Header. Insert Power Wiring through the 7/8 inch hole located at the left or right side of Header End Cap.
2. Flush Header to the Pivot Door Jamb and then line up the screw holes.
3. Secure the Header to the Door Frame. It is recommended to use Lag Bolts.

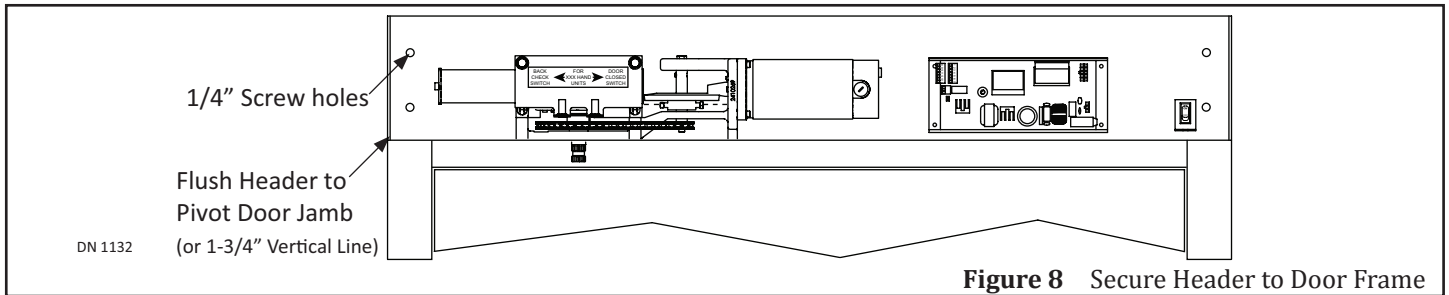

Figure 8 Secure Header to Door Frame

SECTION 3: 120 VAC GENERAL WIRING

WARNING

Shut the installation site, branch Circuit Breaker OFF. Failure to do so may result in serious personal or fatal injury. When uncertain whether power supply is disconnected, always verify using a voltmeter. Ensure Grounding of the Electric Power Supply is installed/connected in a proper way (especially the PE Cable from the Building Side).

WARNING

All high voltage electrical connections must be made by licensed electricians according to National and Local electrical codes/regulations. Permanent wiring shall be employed as required by local codes. It is recommended to house 120 VAC wiring within an Electrical Conduit.

CAUTION

Keep all Incoming 120 VAC wiring separate from low voltage wiring within Header. 120 VAC Power wires must be routed (separate from other wiring) located near the top of inside Header and inserted through the Access Hole located at the left or right side of Header End Cap.

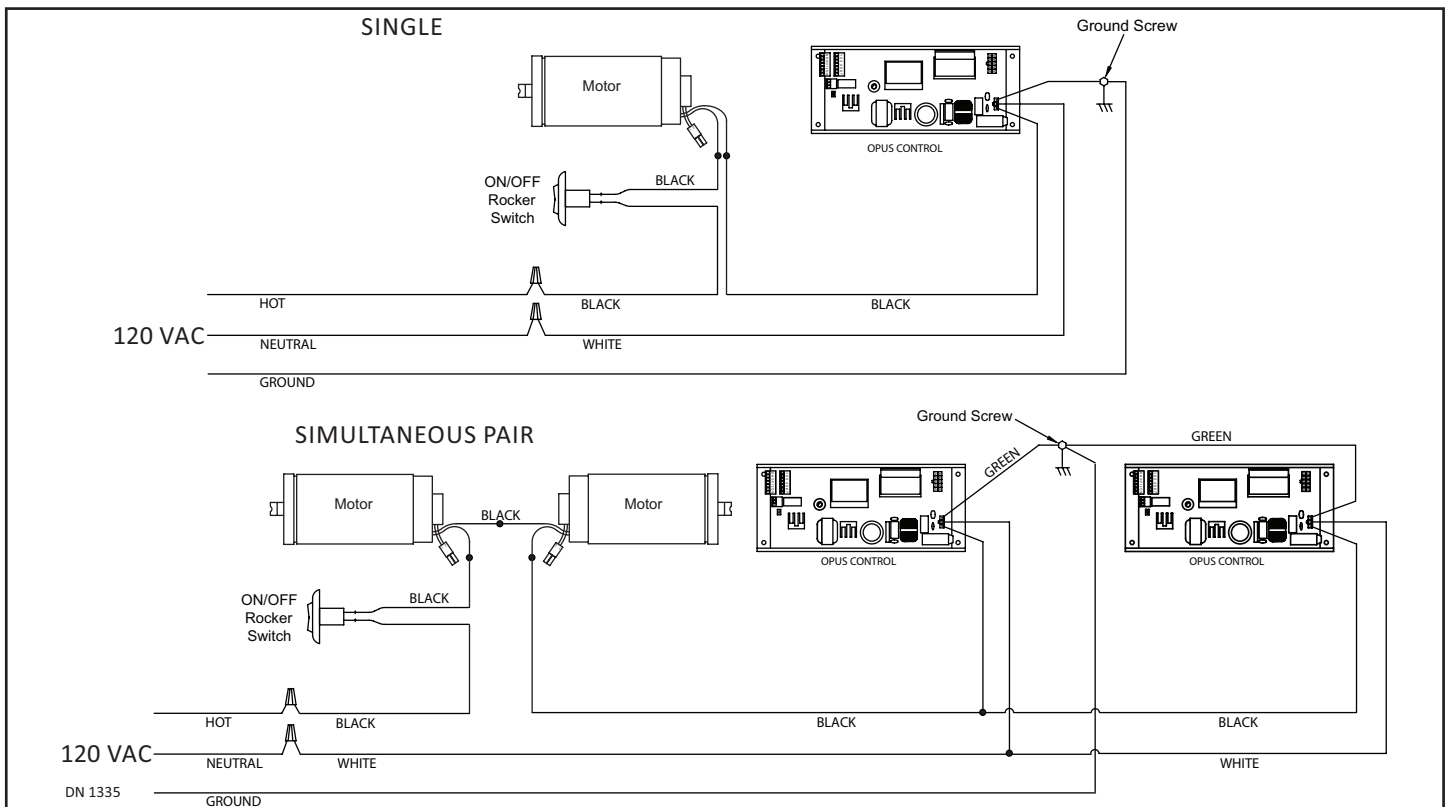

SECTION 4: INSTALL THE OUTSWING ARM SHOE ASSEMBLY

4.1 Prep the Swing Door

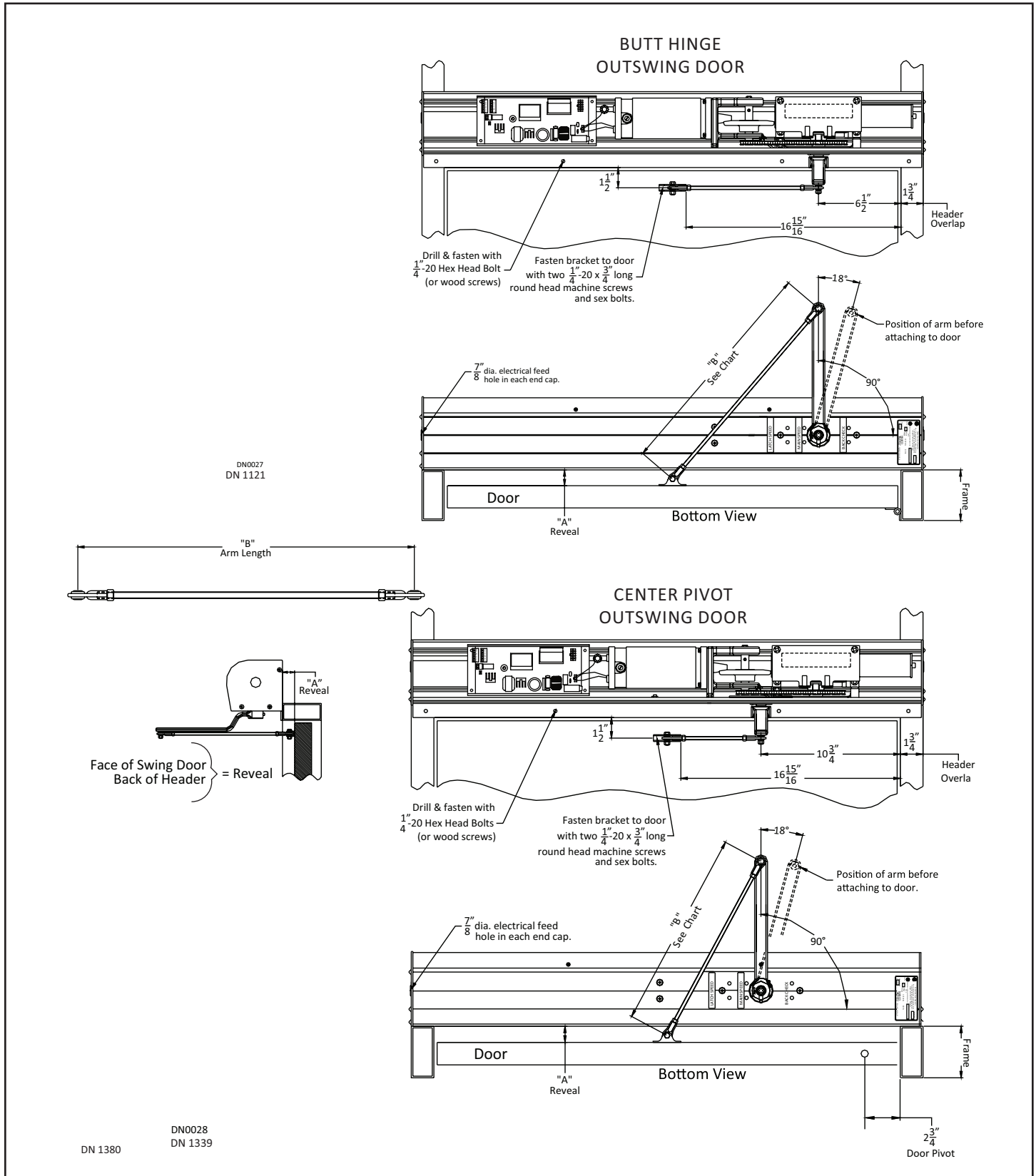

4.2 Prep and Secure the Outswing Arm Shoe Assembly

1. Please refer to Table 1 or Table 2 to obtain the appropriate full length measurement of the Outswing Arm.

Table 1 Dimension "B" Full Length of Outswing Arm for **BUTT HINGE**

Dim A Reveal	Dim B Length	Dim A Reveal	Dim B Length	Dim A Reveal	Dim B Length	Dim A Reveal	Dim B Length	Dim A Reveal	Dim B Length
0"	16-5/8"	3-1/4"	19-1/8"	6-1/2"	21-3/4"	9-3/4"	24-5/8"	13	27-1/2"
1/4"	16-13/16"	3-1/2"	19-5/16"	6-3/4"	22"	10	24-13/16"	13-1/4"	27-3/4"
1/2"	17"	3-3/4"	19-1/2"	7"	22-3/16"	10-1/4"	25"	13-1/2"	28"
3/4"	17-3/16"	4"	19-11/16"	7-1/4"	22-7/16"	10-1/2"	25-1/4"	13-3/4"	28-3/16"
1"	17-3/8"	4-1/4"	19-7/8"	7-1/2"	22-5/8"	10-3/4"	25-1/2"	14	28-7/16"
1-1/4"	17-9/16"	4-1/2"	20-1/8"	7-3/4"	22-7/8"	11	25-3/4"	14-1/4"	28-5/8"
1-1/2"	17-3/4"	4-3/4"	20-5/16"	8"	23"	11-1/4"	25-15/16"	14-1/2"	28-7/8"
1-3/4"	17-15/16"	5"	20-1/2"	8-1/4"	23-1/4"	11-1/2"	26-3/16"	14-3/4"	29-1/8"
2"	18-1/8"	5-1/4"	20-3/4"	8-1/2"	23-1/2"	11-3/4"	26-3/8"	15	29-3/8"
2-1/4"	18-5/16"	5-1/2"	20-15/16"	8-3/4"	23-3/4"	12	26-5/8"	15-1/4"	29-9/16"
2-1/2"	18-1/2"	5-3/4"	21-1/8"	9"	24"	12-1/4"	26-13/16"	15-1/2"	29-13/16"
2-3/4"	18-11/16"	6"	21-3/8"	9-1/4"	24-3/16"	12-1/2"	27-1/16"	15-3/4"	30"
3"	18-7/8"	6-1/4"	21-9/16"	9-1/2"	24-3/8"	12-3/4"	27-5/16"	16	30-1/4"

Table 2 Dimension "B" Full Length of Outswing Arm for **CENTER PIVOT**

Dim A Reveal	Dim B Length	Dim A Reveal	Dim B Length	Dim A Reveal	Dim B Length	Dim A Reveal	Dim B Length	Dim A Reveal	Dim B Length
0"	14"	3-1/4"	16-7/8"	6-1/2"	19-7/8"	9-3/4"	22-15/16"	13	26"
1/4"	14-1/4"	3-1/2"	17-1/8"	6-3/4"	20-1/8"	10	23-1/8"	13-1/4"	26-1/4"
1/2"	14-7/16"	3-3/4"	17-3/8"	7"	20-3/8"	10-1/4"	23-3/8"	13-1/2"	26-1/2"
3/4"	14-11/16"	4"	17-9/16"	7-1/4"	20-9/16"	10-1/2"	23-5/8"	13-3/4"	26-3/4"
1"	14-7/8"	4-1/4"	17-13/16"	7-1/2"	20-7/8"	10-3/4"	23-7/8"	14	27"
1-1/4"	15-1/8"	4-1/2"	18"	7-3/4"	21"	11	24-1/8"	14-1/4"	27-1/4"
1-1/2"	15-5/16"	4-3/4"	18-1/4"	8"	21-1/4"	11-1/4"	24-3/8"	14-1/2"	27-1/2"
1-3/4"	15-9/16"	5"	18-1/2"	8-1/4"	21-1/2"	11-1/2"	25-5/8"	14-3/4"	27-3/4"
2"	15-3/4"	5-1/4"	18-3/4"	8-1/2"	21-3/4"	11-3/4"	25-13/16"	15	28"
2-1/4"	16"	5-1/2"	18-15/16"	8-3/4"	22"	12	25-1/16"	15-1/4"	28-3/16"
2-1/2"	16-1/4"	5-3/4"	19-3/16"	9"	22-1/4"	12-1/4"	25-5/16"	15-1/2"	28-7/16"
2-3/4"	16-7/16"	6"	19-3/8"	9-1/4"	22-7/16"	12-1/2"	25-9/16"	15-3/4"	28-11/16"
3"	16-11/16"	6-1/4"	19-5/8"	9-1/2"	22-11/16"	12-3/4"	25-13/16"	16	28-15/16"

2. Remove the Swing Arm from the Threaded Rod.

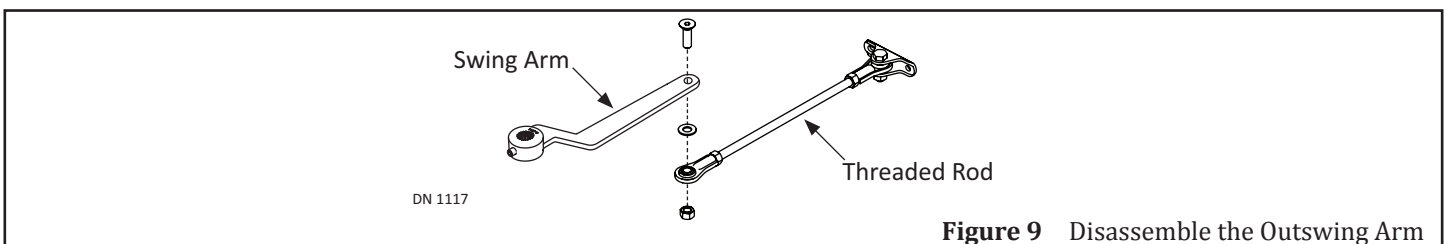

3. Measure between the center of each Eye located at each end of the Outswing Rod.
4. Write that measurement down.

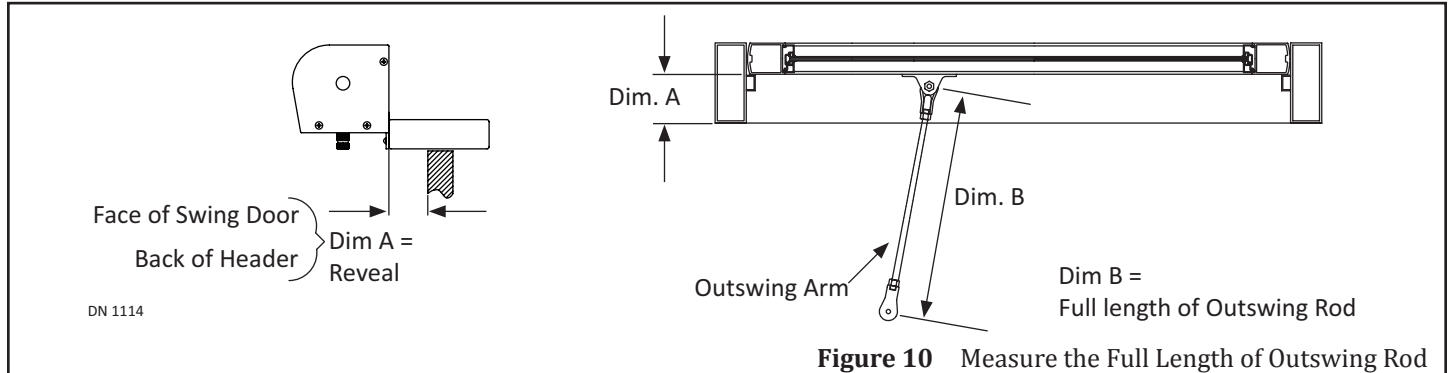

5. Remove the Link from the Threaded Rod (that is not used to attach the Arm Shoe).

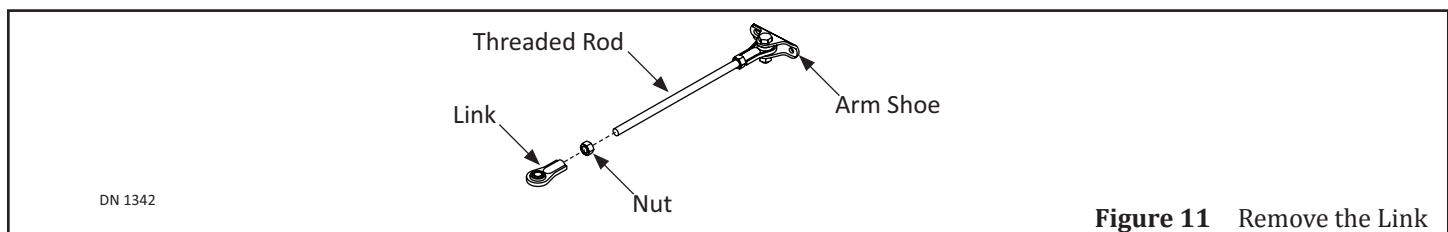

6. Cut the Threaded Rod until the appropriate Full Length measurement is achieved (according to Table 1 or Table 2).
 - a. The Threaded Rod will be approximately 1 inch shorter than the full length measurement.
7. Obtain (1) color coordinated Plastic Tube from the Outswing Rod assembly.
8. Cut the Plastic Tube to the same length as the exposed Rod (between the Links and Nuts).
9. Slide the Plastic Tube over the Threaded Rod.
10. Replace the Rod Link back onto the Threaded Rod. Tighten Nut against the Link to prevent the Rod from screwing In or Out.
11. Go to the back of the Swing door. Insert each Sex Bolt into the drilled holes.
12. Go to the front of the Swing door. Secure the Arm Shoe to the Swing Door with (2) 1/4-20 x 2-1/4" Screws.

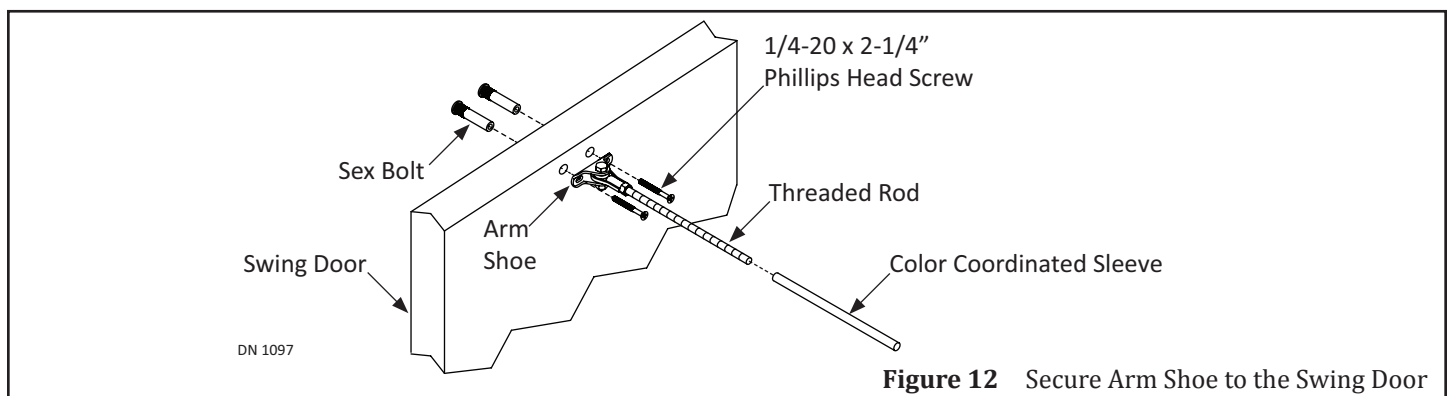

SECTION 5: INSTALL THE INSWING ARM TRACK

5.1 Prep the Door for Inswing Arms with Reveal

1. Measure and mark a Horizontal Line from the (Center Hinge or Butt Hinge) to the center of the Face of Door according to Table 3 or Table 4 (Track Mounting Locations).

Table 3 Small Track Mounting Locations (12-1/4 inches)

Dim A Reveal	Dim B Butt Hinge	Dim C Center Pivot
0	7-5/8"	7-3/16"
1/4"	7-3/4"	7-3/8"
1/2"	7-15/16"	7-9/16"
3/4"	8-1/8"	7-3/4"
1"	8-5/16"	7-15/16"
1-1/4"	8-1/2"	8-1/8"
1-1/2"	8-11/16"	8-5/16"
1-3/4"	8-7/8"	8-1/2"
2"	8-1/16"	8-3/4"
2-1/4"	8-1/4"	8-15/16"
2-1/2"	8-1/2"	9-1/8"

Dim A Reveal	Dim B Butt Hinge	Dim C Center Pivot
2-3/4"	8-11/16"	9-3/8"
3"	13-1/8"	9-9/16"
3-1/4"	13-3/8"	13-1/16"
3-1/2"	13-9/16"	13-1/4"
3-3/4"	13-3/4"	13-1/2"
4"	14"	13-11/16"
4-1/4"	14-3/16"	13-3/4"
4-1/2"	14-7/16"	
4-3/4"	14-1/2"	
5"		
5-1/4"		13-13/16"

Dim A Reveal	Dim B Butt Hinge	Dim C Center Pivot
5-1/2"	14-1/2"	13-13/16"
5-3/4"		
6"		
6-1/4"	18-1/2"	17-7/8"
6-1/2"		
6-3/4"	18-9/16"	17-15/16"
7"		
7-1/4"	18-5/8"	N/A
7-1/2"		

Table 4 Large Track Mounting Locations (21 inches)

Dim A Reveal	Dim B Butt Hinge	Dim C Center Pivot no Finger Guard
7-1/2"	N/A	13-1/2"
7-3/4"	14-1/4"	13-9/16"
8"		13-9/16"
8-1/4"		13-5/8"
8-1/2"		
8-3/4"		
9"		
9-1/4"	13-9/16"	
9-1/2"		
9-3/4"		
10"	14-3/16"	
10-1/4"		

Dim A Reveal	Dim B Butt Hinge	Dim C Center Pivot no Finger Guard
10-1/2"	19-1/4"	13-9/16"
10-3/4"		18-5/8"
11"		18-11/16"
11-1/4"		
11-1/2"		
11-3/4"		
12"		
12-1/4"		
12-1/2"		
12-3/4"		
13"		

- Measure 1 - 11/16 inches from the Bottom of Door Frame to the Horizontal Line. Mark a vertical line across the Horizontal Line. This is the center of the first Sex Bolt hole. For Zero Reveal, please refer to Sub-subsection 5.1.1 "Zero Reveal".

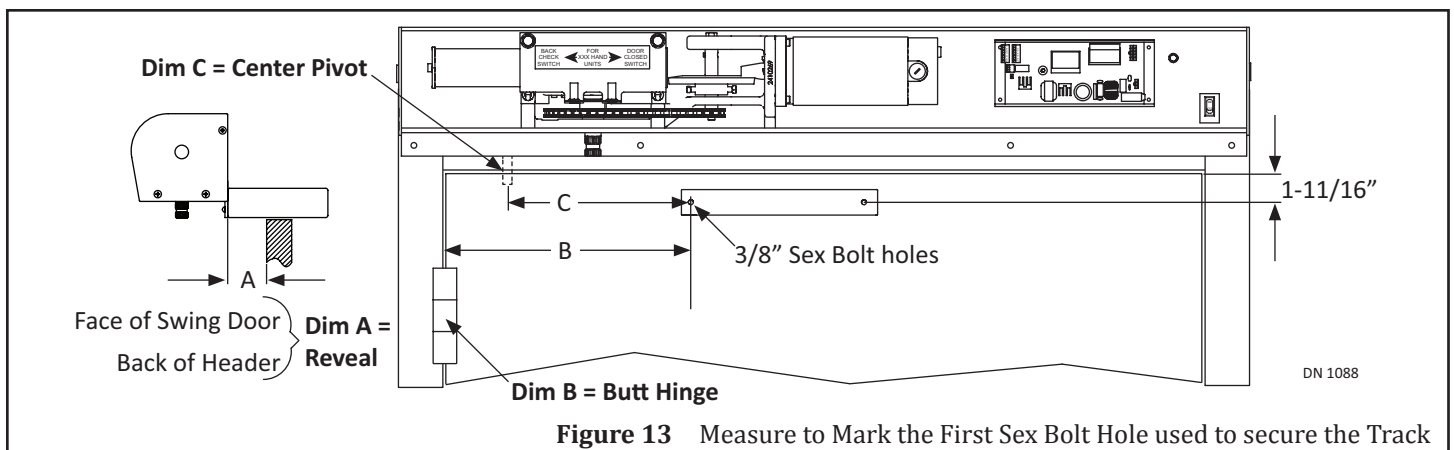

Figure 13 Measure to Mark the First Sex Bolt Hole used to secure the Track

3. Butt the Track against the Swing door by aligning the first Sex Bolt hole with the measured Mark.
4. Ensure the Track is square and level.
5. Use the Track as a Template to mark the second Sex Bolt hole. Set aside.

5.2 Prep the Door for Inswing Arms with Zero Reveal

Note: For zero Reveal applications, the Straight Arm can be used to eliminate the L-Shape Arm from protruding into the room.

- ▶ Straight Arm:
 - Measure 11/16 inch from the Bottom of Door Frame down to the Horizontal Line. Mark a vertical line across the Horizontal Line. This is the center of the first Sex Bolt hole.
- ▶ L-Shape Arm:
 - Measure 1-11/16 inch from the Bottom of Door Frame down to the Horizontal Line. Mark a vertical line across the Horizontal Line. This is the center of the first Sex Bolt hole.

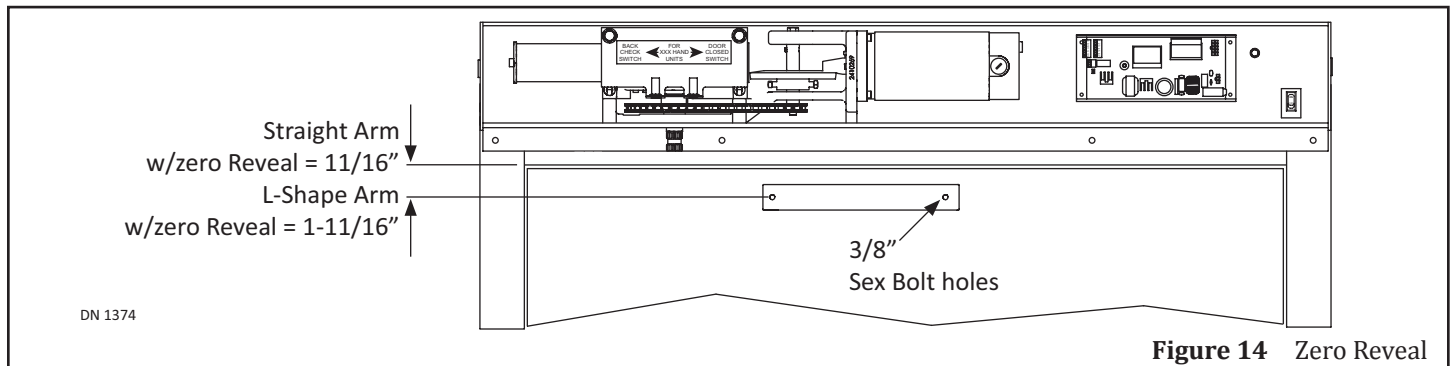

5.3 Secure the Track to the Door

1. Drill (2) 3/8 inch bolt holes all the way through the Swing door.
2. Go to the back of the Swing door. Insert each Sex Bolt into the drilled holes.
 - a. If a Straight Arm is being used with a (zero or small reveal), and, if the wall/frame is not straight, vertical, plum etc., install (1) Spacer (21-0902) behind the Track only if Reveal has a variance of zero to 1/4 inch and a Straight Arm is being installed.
 - b. A Spacer is used to prevent the Swing Arm from hitting the lip of the GT-710 Header only (the GT-8710 Header does not have a lip).
 - c. If a Spacer can not be obtained, a couple of washers can be used.
3. Go to the front of the Swing door.
4. Butt the Track against the Swing door by aligning the Sex Bolt holes.
 - a. Install (1) Spacer behind the Track for Swing doors with "0" Reveal (If required).
5. Secure the Track to the Swing Door with (2) 1/4-20 x 2-1/4" Screws.

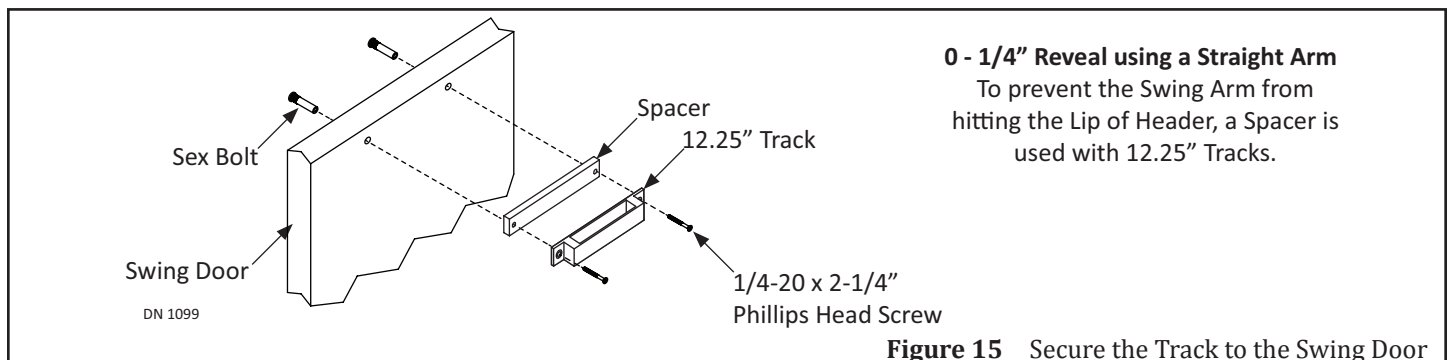

SECTION 6: INSTALL THE SECOND HALF OF SWING ARM

6.1 Set Pre-Load

WARNING

Proper Preload is critical for the Control/Operator to open/close the Swing Door correctly.

CAUTION

Power must be turned OFF during the Swing Arm installation.

1. Locate pre-load numbers 1-4 on the Bottom of the Operator Spindle. Pre-load numbers 1-4 mark the correct installation position for pre-load.

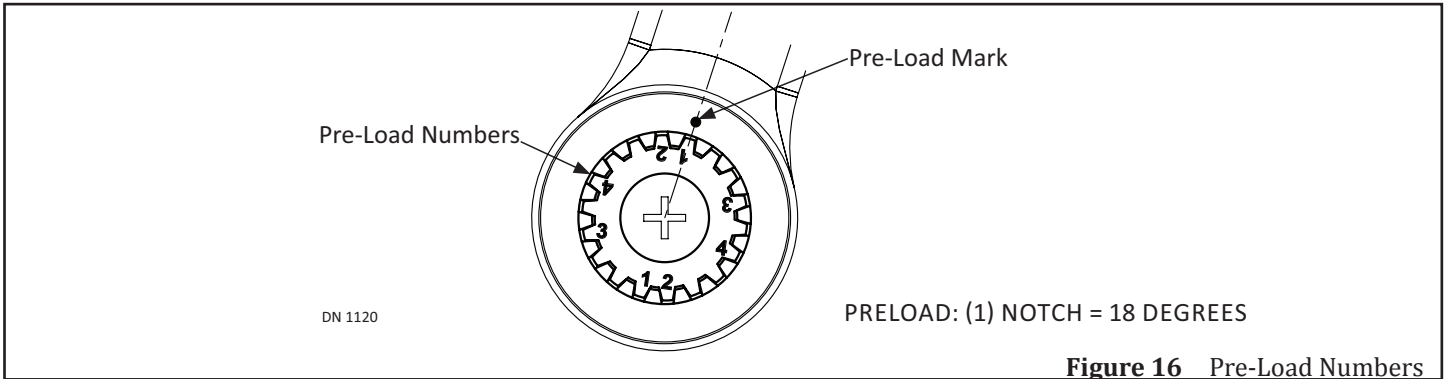

Figure 16 Pre-Load Numbers

2. Slide the Swing Arm onto the Operator Spindle by aligning the appropriate pre-load number to the pre-load mark on the underside of Swing Arm:

RH Outswing	LH Outswing	RH Inswing	LH Inswing	RH Inswing-0 Reveal	LH Inswing-0 Reveal
1	2	3	4	4	3

3. Please see Figure 17, or Figure 18, or Figure 19.

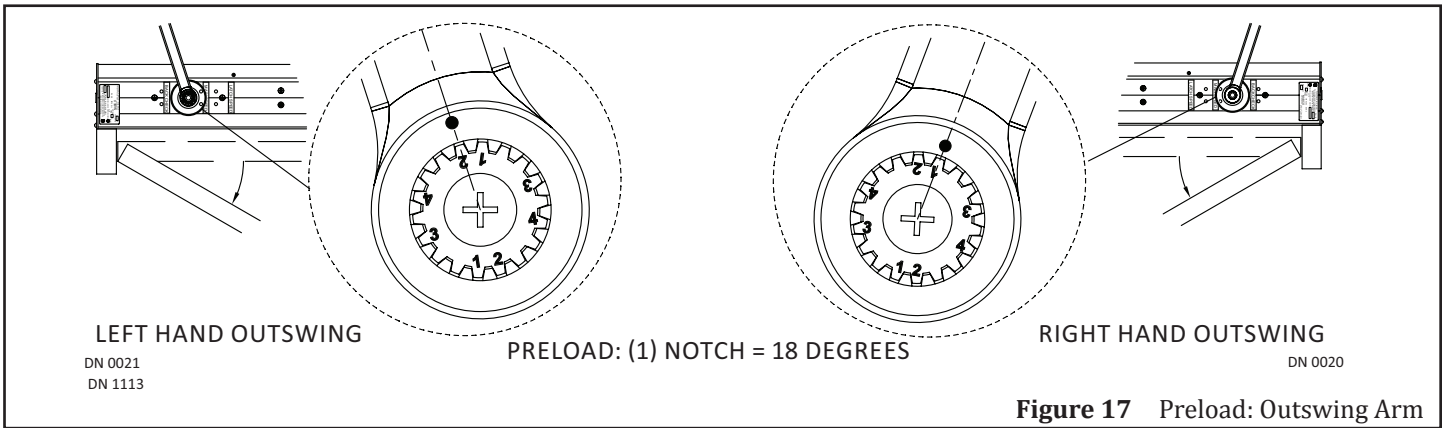

Figure 17 Preload: Outswing Arm

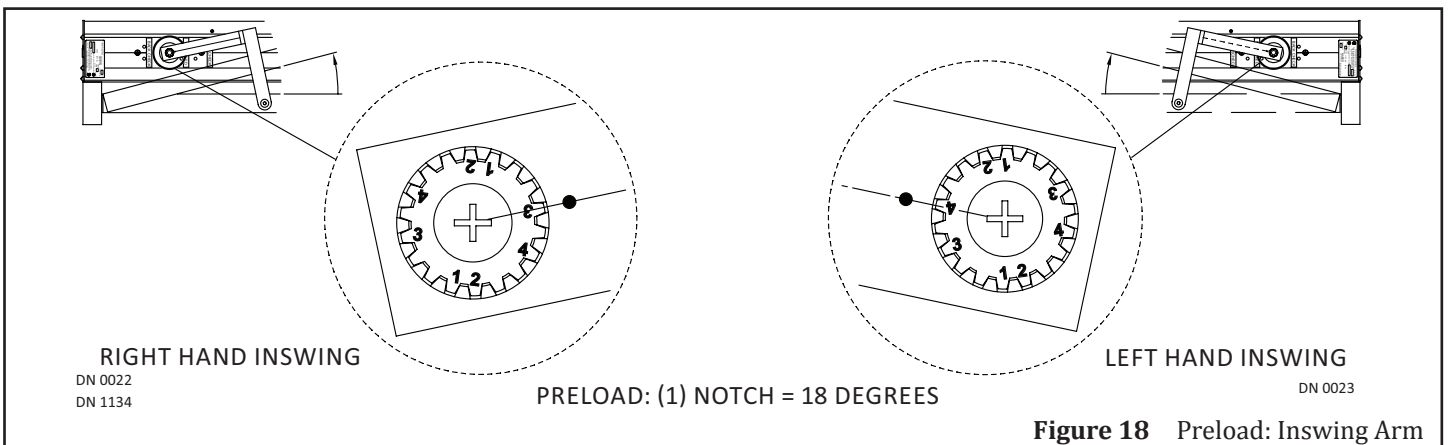

Figure 18 Preload: Inswing Arm

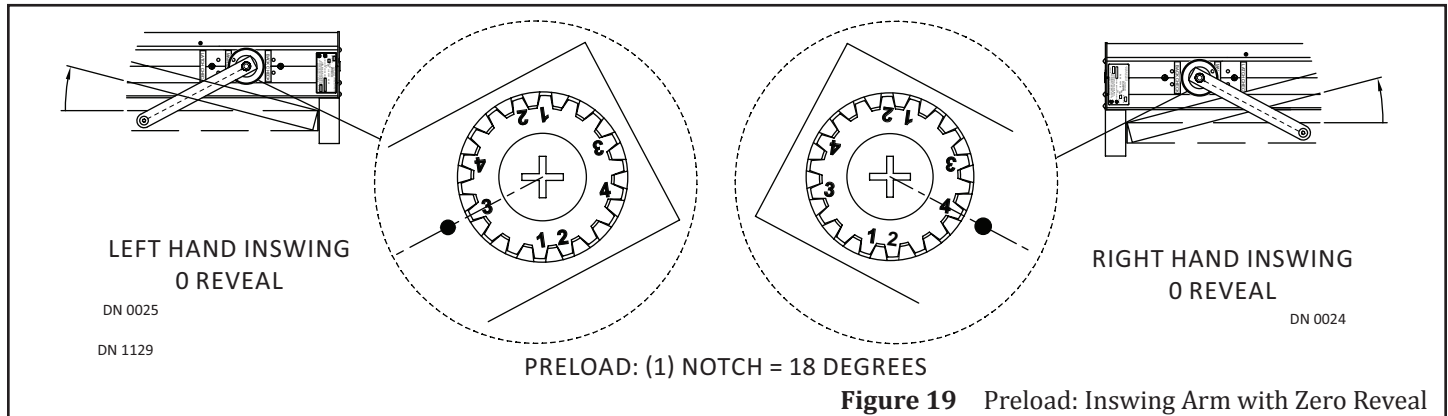

Figure 19 Preload: Inswing Arm with Zero Reveal

4. Secure the Swing Arm to the Operator Spindle with (1) Set Screw. Tighten but do not overtighten.
 - a. Ensure the Set Screw is seated correctly within the groove on the Operator Spindle.

6.2 Secure the Swing Arm to the Swing Door

6.2.1 Inswing Arm

1. Remove the first 1/4-20 x 2-1/4" Screw (closest to the Pivot Door Jamb) that is used to secure the Track to the Swing door.
 - a. That side of the Track will hang down.
2. Close the Swing door to allow the Wheeled Roller (located at the end of the Swing Arm) to butt against the Swing door.
3. Pull the Swing Arm to the Swing door, then raise the Track.
4. Resecure the Track to the Swing door with (1) 1/4-20 x 2-1/4" Screw.

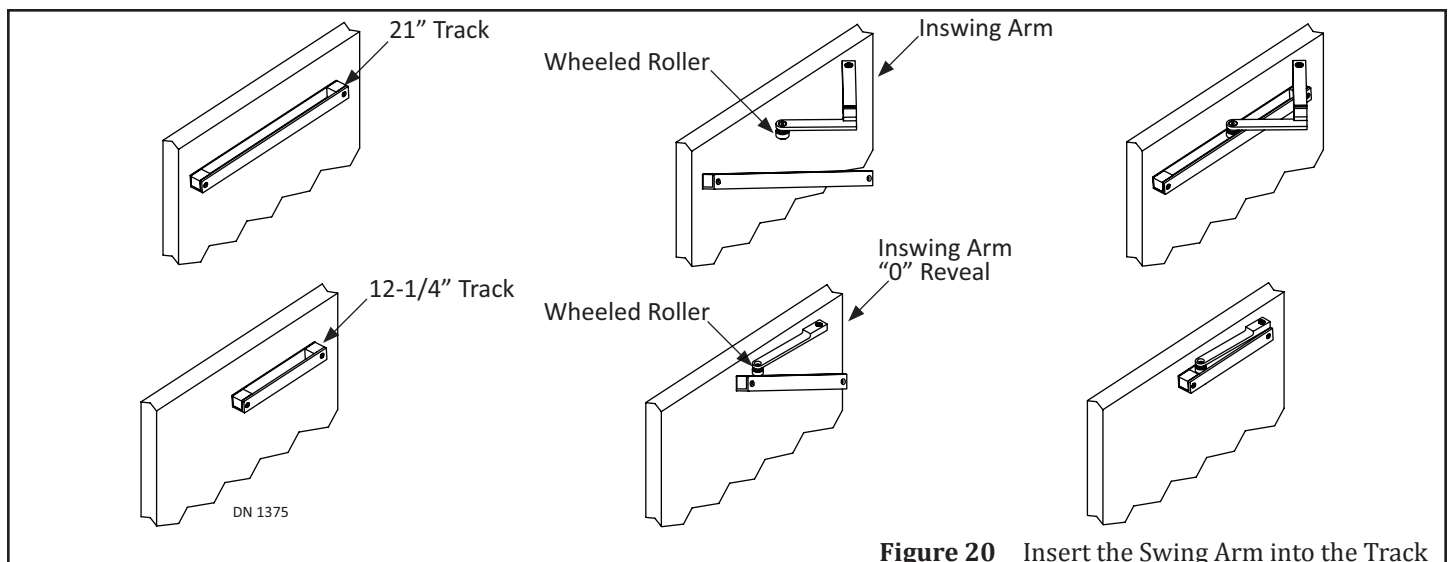

Figure 20 Insert the Swing Arm into the Track

6.2.2 Outswing Arm

1. Align the screw hole at the end of Swing Arm to the Rod End screw hole.
2. Pull the Swing Arm towards the Rod to connect.
3. Secure the Swing Arm to the Threaded Rod with (1) 3/8"-24 x 1-1/4" Socket Screw, (1) .405 Washer, and (1) 3/8"-24 Lock Nut.

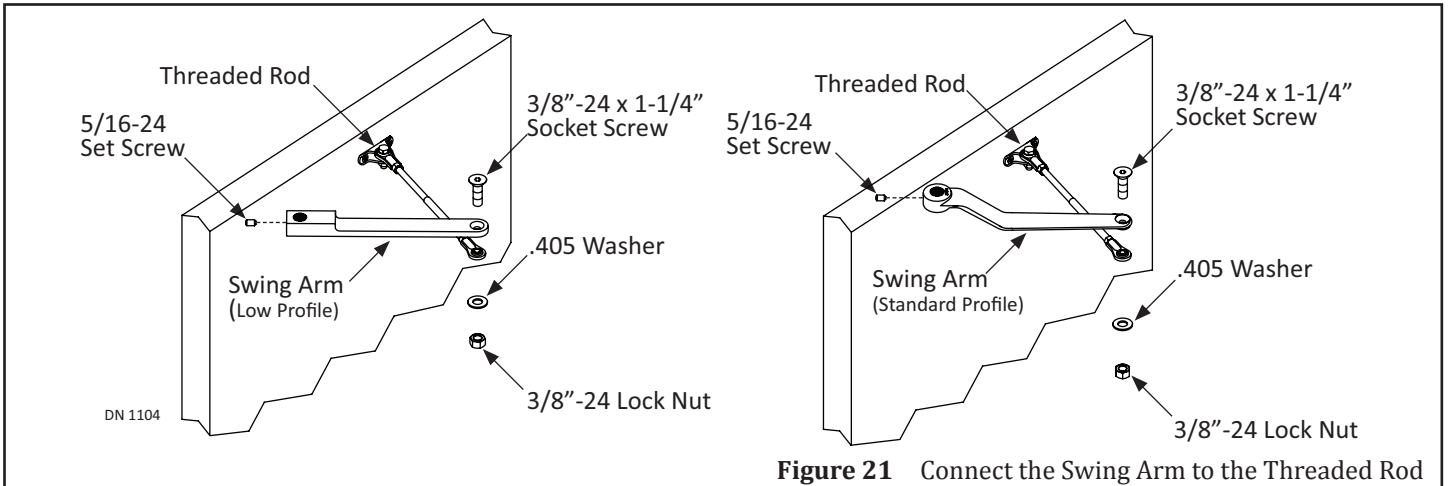

Figure 21 Connect the Swing Arm to the Threaded Rod

SECTION 7: INSTALL THE ARM STOP

CAUTION

Power must be turned OFF while installing the Arm Stop.

CAUTION

Do Not drill screw holes for the Arm Stop into the Motor/Operator!!!

1. Turn Power OFF.
2. Manually open the Swing Door 90 degrees or Full Open position.
3. Position the Arm Stop at the bottom of Header according to type of Swing Arm and Reveal.
4. Use the Arm Stop as a template to mark and drill (2) 7/32 inch diameter screw holes.
5. Secure the Arm Stop with (2) 1/4-20 x 1 inch Self Tapping screws.

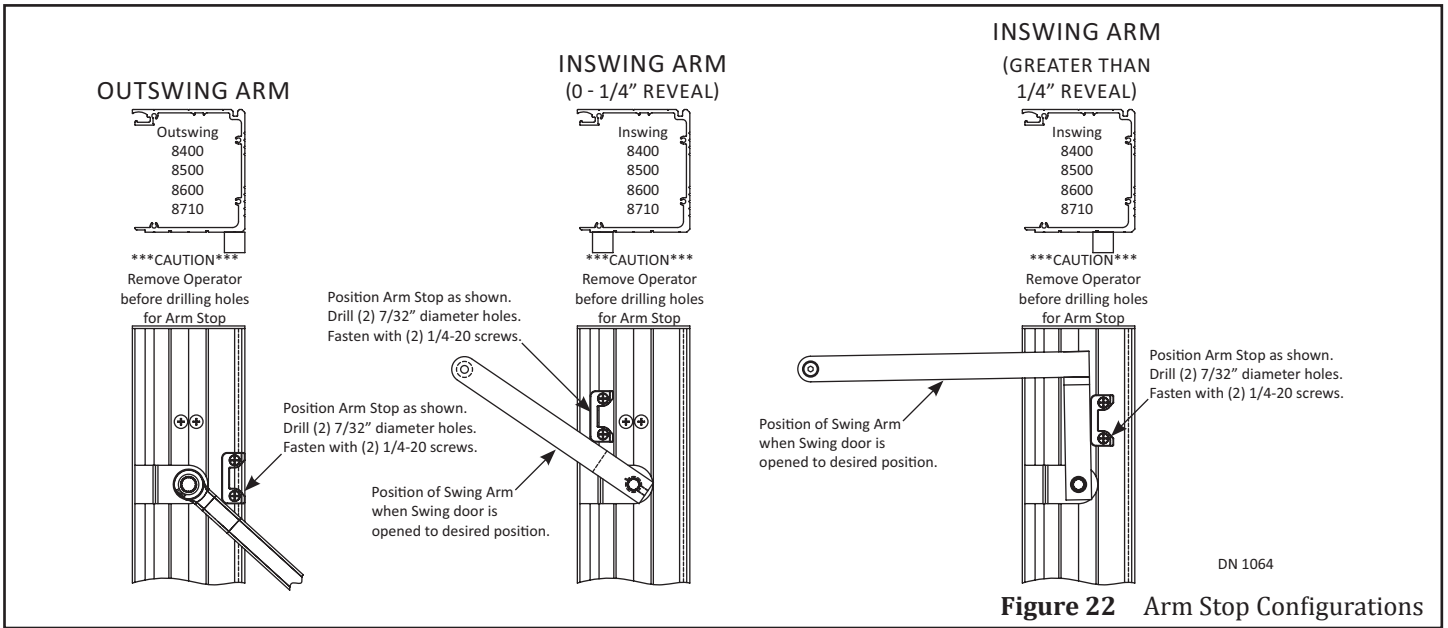

Figure 22 Arm Stop Configurations

SECTION 8: ADJUSTMENTS

8.1.1 Adjust Opening/Closing Force on LCN Tension Spring

WARNING

Improperly installed/adjusted Tension Springs may cause property damage or personal injury. Please follow instructions carefully.

CAUTION

Opening Force must be properly adjusted on the LCN Tension Spring - BEFORE - the Magnum 4A Control can be adjusted.

The LCN Tension Spring is used to adjust Opening/Closing Force when the Swing door is used Manually. The Factory preset force is ideal in most cases. Adjustment should only need to be done in special cases.

1. Turn Power OFF.
2. Insert 5/32 Allen Wrench in the Screw located at the end of the LCN Tension Spring.
 - a. The Spring should be adjusted so that the Swing door can be easily pushed open, but still have enough force to fully close the Swing door.
3. To Increase Closing Force, turn the 5/32 Allen wrench clockwise not more than (9) full turns.
4. To Decrease Closing Force, turn the 5/32 Allen wrench counterclockwise not more than (4) full turns.

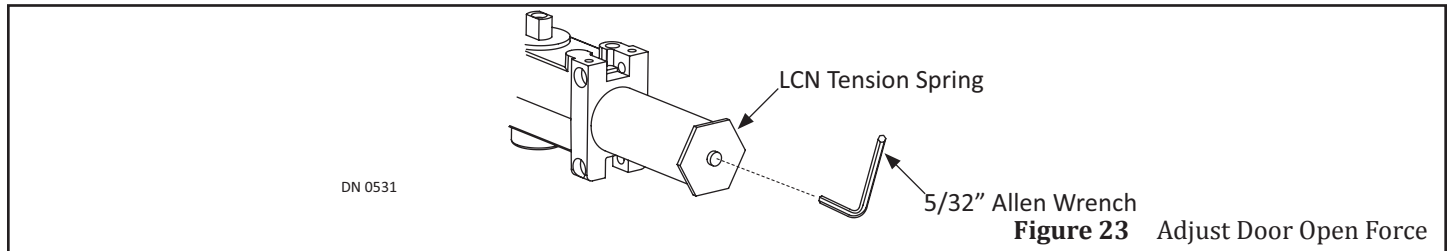

8.1 Hydraulic Speed Control

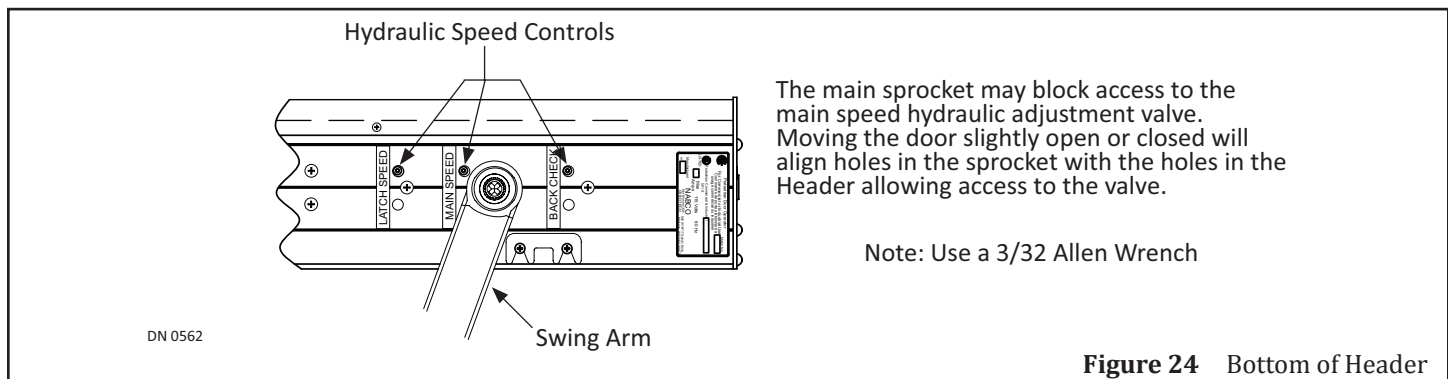

8.2 Adjust Main Speed

1. Turn Power OFF.
2. Insert 3/32 Allen Wrench into the Main Speed adjustment hole.
 - a. If the adjustment hole is blocked by the sprocket, slightly close the Swing door until the adjustment Valve can be accessed.
3. Turn the Allen Wrench clockwise to slow down closing speed.

8.3 Adjust Latch Speed

1. Turn Power OFF.
2. Insert 3/32 Allen Wrench into the Latch Speed adjustment hole.
3. Turn the Allen Wrench clockwise to slow down Latch Check speed.
4. To test Latch Check speed. Manually push the Swing door open, then let it close.
 - a. Re-adjust if necessary.

8.4 Adjust Back Check Speed

This adjustment should not be confused with the Back Check (BCHK) setting located on the Opus Control. BCHK determines the amount of power applied to the motor to push the door open through Back Check.

1. Turn Power OFF.
2. Insert Allen Wrench into the Back Check Speed adjustment hole.
3. Turn Allen Wrench clockwise to increase hydraulic tension at back check.
4. To test Back Check speed. Manually push the Swing door open. The Door should slow down and not slam open.
 - a. Re-adjust if necessary.

SECTION 9: TROUBLESHOOTING

If the Opus detects an error, the LCD backlight will start flashing and display an Error message within the Error Screen or before the Level Two Screen.

Table 1: Error Message

Error Msg	Description	Resolution
Recycle Warning	Recycle was detected more than (5) times while opening or closing cycle continuously.	<ul style="list-style-type: none"> ▶ Check Door Way and Door resistance. <ul style="list-style-type: none"> • If both are normal, adjust the opening and closing recycle sensitivity.
MPU Error	Microprocessor detects errors within the Internal or External Circuit.	Please replace the Opus Control if the MPU Error occurs repeatedly.
Drive Circuit Error	If the Drive Circuit detects an unusual state, the Opus will stop door movement. Possible causes are: <ul style="list-style-type: none"> ▶ Over current at motor ▶ Abnormal voltage at Motor Circuit ▶ Abnormal value from Motor Current detection. 	<ul style="list-style-type: none"> ▶ Check the Motor connection. <ul style="list-style-type: none"> • Opus Control may not be connected to the motor. • Motor wire may be shorted. ▶ If Motor connection is normal; the cause could be electrical noise. ▶ Possible for this Error to occur occasionally without having a problem with the Door.
Communication Error	CAN-bus Communication Error	Please check SimPair Harness.
62 Sensor Error & 6B Sensor Error & SWL Sensor Error	<ul style="list-style-type: none"> ▶ This is the Sensor monitoring functionality. ▶ Hand-shake for Safety Sensor not working properly. 	<ul style="list-style-type: none"> ▶ Check Opus: <ul style="list-style-type: none"> • Input/Output Settings • Harnesses • Sensor Status. ▶ Sensor could be detecting an Internal Error.

Notice: If after troubleshooting a problem, and a satisfactory solution cannot be achieved, please call Nabco Entrances at 1-877-622-2694 between 8 am – 4:30pm Central time for additional assistance.

DO NOT leave any problem unresolved. If the door cannot be repaired immediately, turn off the door and leave it inoperable until repairs can be made. Advise the owner **NOT** to operate the door in the automatic mode until repairs are effected. **NEVER** leave a door operating without all safety detection systems operational.

SERVICE PARTS: GT 710 LOW ENERGY HEADER

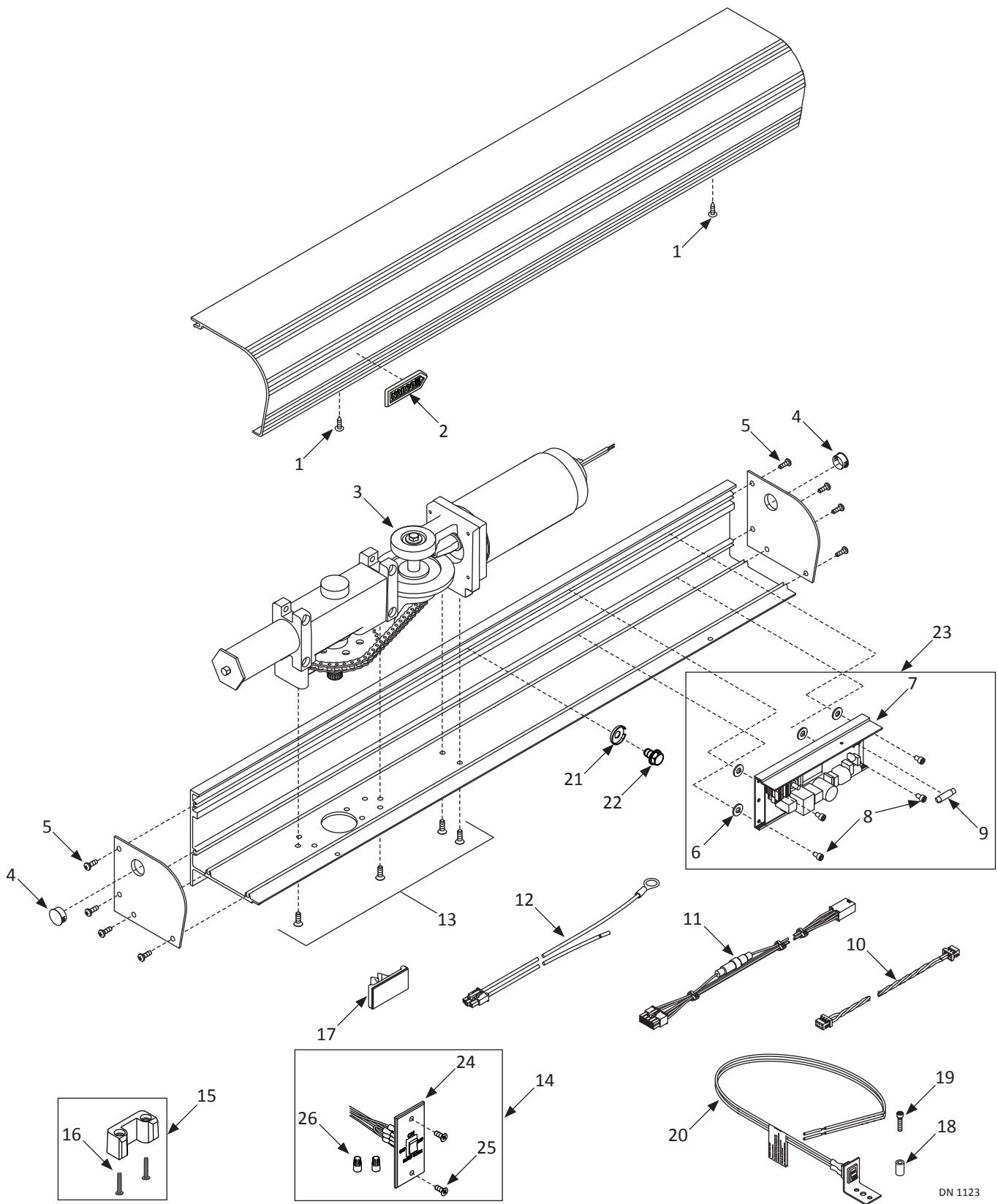

DN 1123

GT 710 Low Energy Header			
Item	Part	Finish/Sizes/Notes	Description
1	T-00337		PHSMS:#8x0.625L.:PHIL
2	C-00067		NAMEPLATE,NABCO LOGO
3	A-00883	RH	"OPERATOR, GT710 - OPUS,RH"
	A-00884	LH	"OPERATOR, GT710 - OPUS,LH"
4	V-00720		"PLUG,HOLE,13/16 DOME"""
5	T-00326	Zinc	RHMS,1/4-20x0.750L.,PHIL,ZINC SELF TAPNG
	T-00393	Dark Bronze	RHMS,1/4-20x0.750L.,PHIL,F-POINT,BK OX
6	T-00365		WASHER,.170 ID,.625 OD,.032 THK,NYLON
7	M-01546		CONTROLLER,OPUS
8	T-00335		SHCS,10-24x0.313L.,ZINC
9	V-00552	Used on Opus Control	FUSE;5A;GMA;5X20mm
	V-00713	Used on A-01249	FUSE,2 AMP,5X20mm,250V,FAST ACTING
10	M-01680	Simultaneous Pair only	HARNESS,SIM PAIR,OPUS
11	A-01249	For GT710/8710 only	HARNESS,MOTOR,OPUS,710
12	M-01072		HARNESS,POWER,MAGNUM/OPUS
13	T-00015	Zinc	FHMS,1/4-20x0.750L.,PHIL,ZINC
	T-00017	Dark Bronze	FHMS,1/4-20x0.750L.,PHIL,BLK ZN
14	A-00805		SWITCH,ROCKER,SWINGER,ON/OFF/HOLD OPEN
15	A-00454		ARM STOP,ASSEM FOR 400, 8400, 500, 8500
16	T-00325		PHMS, 1/4-20X1.500L, PHIL, TYPE F
17	V-00098		SADDLE, WIRE
18	V-00283		SPACER,CIRCUIT BOARD,STANDOFF
19	T-00232		SHCS,10-24x0.875L.,ZINC
20	M-01085		HARNESS, POWER SWITCH - SWINGERS/710
21	V-00104		WASHER, CUP.312 ID X .88 OD X .040 THICK
22	A-00468		GND.SCREW;HHCS,5/16-18X.500,GREEN
23	A-01097		CONTROLLER,710,OPUS
24	M-01576		SWITCHPLATE,ON/OFF/HOLD OPEN
25	T-00031		FHMS,10-32x0.500L.,PHIL,UCUT,T-LOBE,BKZN
26	T-00197		NUT,WIRE,RANGE 22-14AWG,GREY

SERVICE PARTS: GT 8710 LOW ENERGY HEADER

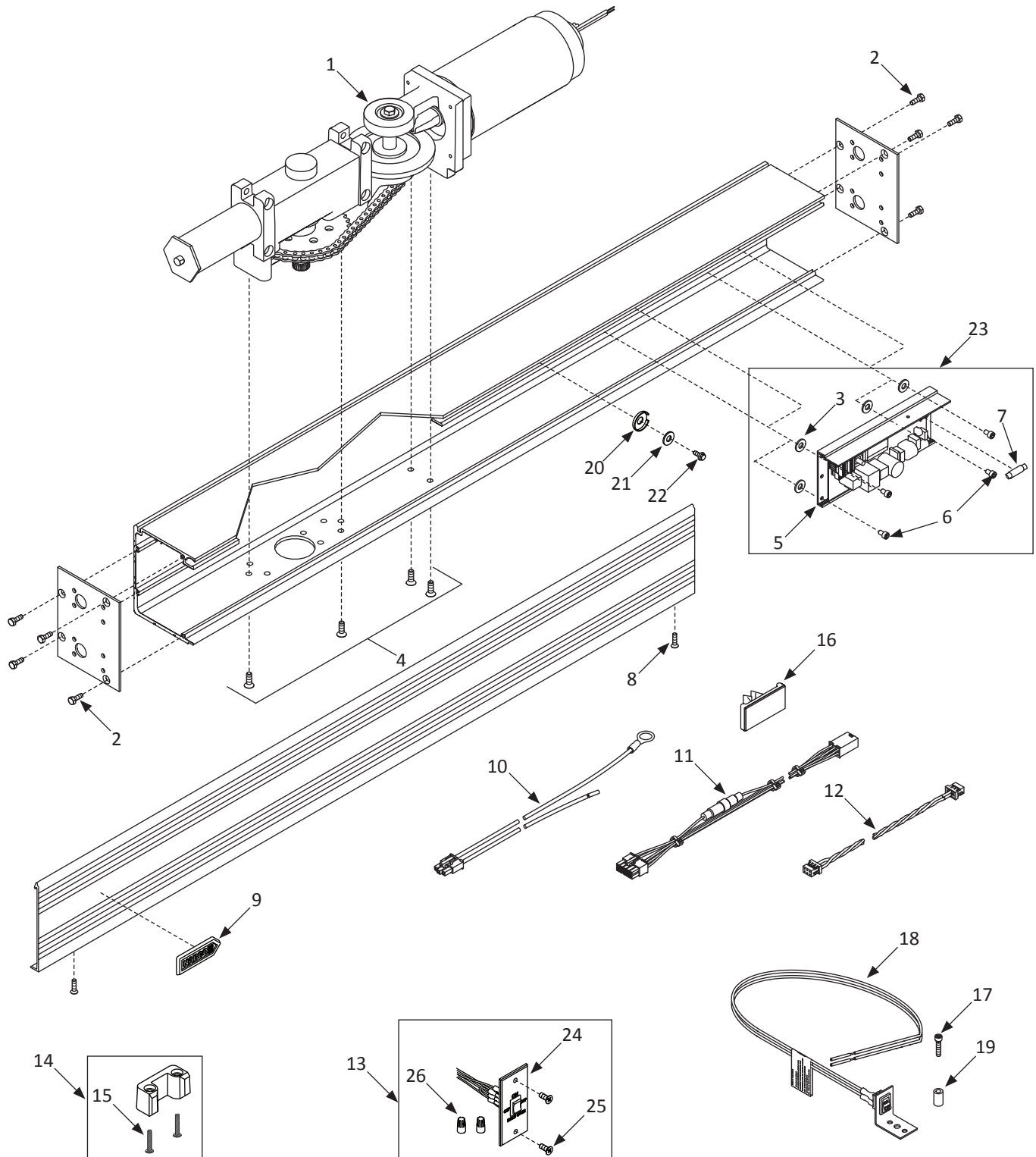

DN 1128

GT 8710 Low Energy Header			
Item	Part	Finish/Sizes/Notes	Description
1	A-00883	RH	"OPERATOR, GT710 - OPUS,RH"
	A-00884	LH	"OPERATOR, GT710 - OPUS,LH"
2	T-00016	Zinc	FHMS,1/4-20x0.438L.,PHIL,UNDERCUT,ZINC
	T-00108	Dark Bronze	FHMS,1/4-20x0.438L.,PHIL,UNDERCUT,BLK ZN
3	T-00365		WASHER,.170 ID,.625 OD,.032 THK,NYLON
4	T-00015		FHMS,1/4-20x0.750L.,PHIL,ZINC
5	M-01546		CONTROLLER,OPUS
6	T-00335		SHCS,10-24x0.313L.,ZINC
7	V-00552	Used on Opus Control	FUSE;5A;GMA;5X20mm
	V-00713	Used on A-01249	FUSE,2 AMP,5X20mm,250V,FAST ACTING
8	T-00337		PHSMS:#8x0.625L.:PHIL
9	C-00067		NAMEPLATE,NABCO LOGO
10	M-01680		HARNESS,SIM PAIR,OPUS
11	A-01249	For GT710/8710 only	HARNESS,MOTOR,OPUS,710
12	M-01072	Simultaneous Pair only	HARNESS,POWER,MAGNUM/OPUS
13	A-00805		SWITCH,ROCKER,SWINGER,ON/OFF/HOLD OPEN
14	A-00454		ARM STOP,ASSEM FOR 400, 8400, 500, 8500
15	T-00325		PHMS, 1/4-20X1.500L, PHIL, TYPE F
16	V-00098		SADDLE, WIRE
17	T-00232		SHCS,10-24x0.875L.,ZINC
18	M-01085		HARNESS, POWER SWITCH - SWINGERS/710
19	V-00283		SPACER,CIRCUIT BOARD,STANDOFF
20	V-00104		WASHER, CUP.312 ID X .88 OD X .040 THICK
21	T-00029		WASHER,.250 ID,.563 OD,.049 THK,ZINC
22	T-00347		HHCS:10-32x0.375L:GREEN:WASH HD:SLOT
23	A-01097		CONTROLLER,710,OPUS
24	M-01576		SWITCHPLATE,ON/OFF/HOLD OPEN
25	T-00031		FHMS,10-32x0.500L.,PHIL,UCUT,T-LOBE,BKZN
26	T-00197		NUT,WIRE,RANGE 22-14AWG,GREY

SERVICE PARTS: SWING ARM ASSEMBLIES

Inswing Arm
Reveal **Equal** to 0 degrees

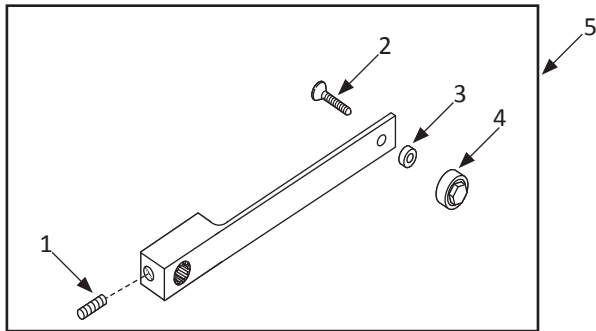

Outswing Arm Assembly

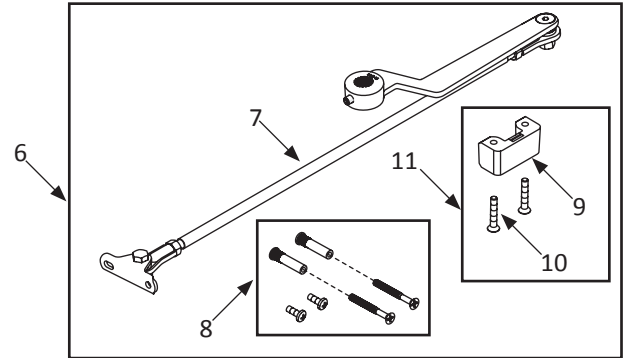

(CU) Inswing Arm Assembly
Reveal Greater than 0 inches

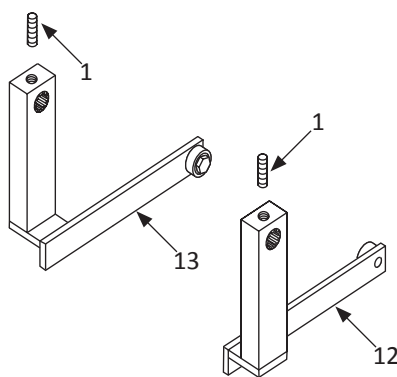

Low Profile
Outswing Arm Assembly

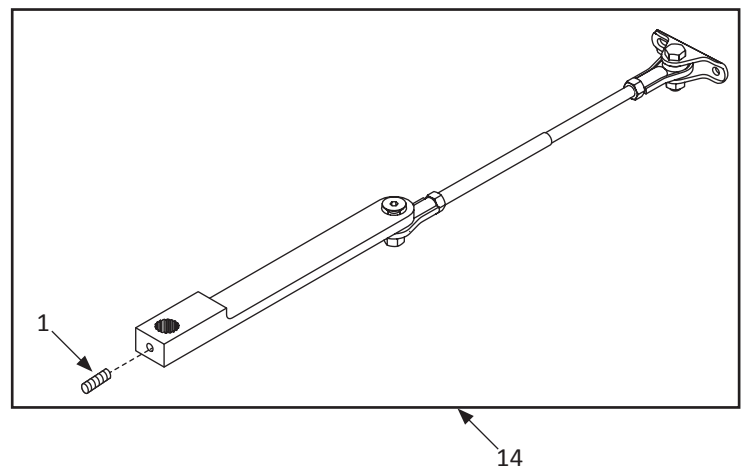

Inswing Track Assembly (12.25 inch)

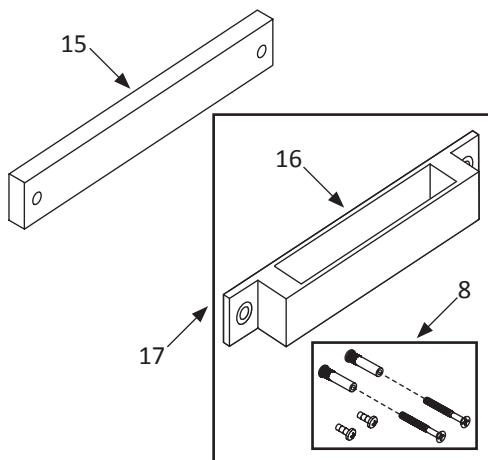

Inswing Track Assembly (21 inch)

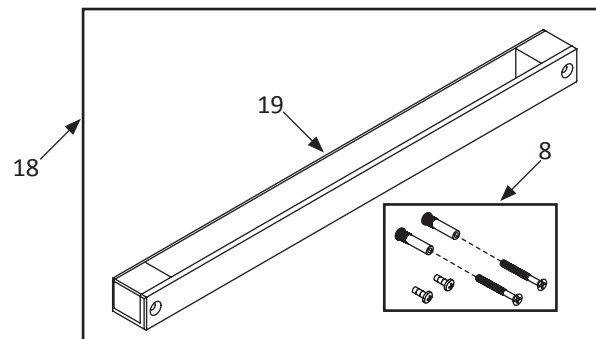

DN 1073

Swing Arm Assemblies			
Item	Part	Finish/Sizes/Notes	Description
1	T-00261		SHSS,5/16-24x0.500L.,CUP PT.
2	T-00223		FHCS,3/8-24x1.250L.,ZINC
3	M-01045		WASHER,STEEL,.375IDx.750Dx.375THK.
4	A-00752		"ROLLER,REPLACEMENT"
5	A-60545	Clear	"ARM,INSWING,CU,NON PANIC,NH,204"
	A-70545	Dark Bronze	ARM,INSWING CU,NO PANIC,NH 313
6	A-60786	Clear	"ARM,OUTSWING,CU.,20in,204,W-STOP"
	A-70786	Dark Bronze	"ARM,OUTSWING,CU.,20in,313,W-STOP"
	A-60787	Clear	"ARM,OUTSWING,,C.U.,30in,204,W-STOP"
	A-70787	Dark Bronze	"ARM,OUTSWING,CU.,30in,313,W-STOP"
7	A-60425	Clear	"ARM,OUTSWING,STD ASM,20in,204"
	A-70425	Dark Bronze	ARM:OUTSWING:STD ASM:20":313
	A-60426	Clear	"ARM,OUTSWING,STD ASM,30in,204"
	A-70426	Dark Bronze	ARM:OUTSWING:STD ASM:30":313
8	A-00389	Clear	PARTS BAG,SEX BOLTS & HARDWARE,204
	A-00388	Dark Bronze	PARTS BAG,SEX BOLTS & HARDWARE,313
9	M-01080		ARM STOP, 710
10	T-00325		PHMS, 1/4-20X1.500L, PHIL, TYPE F
11	A-00471		KIT, GT710 PARTS
12	A-60658	RH/Clear	"INSWING ARM,0 TO 2 REV,RH,204"
	A-70658	RH/Dark Bronze	INSWING ARM:7-3/4:RH:313
	A-60671	RH/Clear	"INSWING ARM,2 TO 5-1/2 REV,RH,204"
	A-70671	RH/Dark Bronze	INSWING ARM:11-1/2:RH:313
	A-60672	RH/Clear	"INSWING ARM5-1/2 TO 9-3/4 REV,RH,204"
	A-70672	RH/Dark Bronze	INSWING ARM:15-3/4:RH:313
	A-60673	RH/Clear	"INSWING ARM,9-3/4 TO 13 REV,RH,204"
	A-70673	RH/Dark Bronze	INSWING ARM:20-1/2:RH:313
13	A-60675	LH/Clear	"INSWING ARM,0 TO 2 REV,LH,204"
	A-70675	LH/Dark Bronze	INSWING ARM:7-3/4:LH:313
	A-60676	LH/Clear	"INSWING ARM,2 TO 5-1/2 REV,LH,204"
	A-70676	LH/Dark Bronze	INSWING ARM:11-1/2:LH:313
	A-60677	LH/Clear	"INSWING ARM,5-1/2 TO 9-3/4,LH,204"
	A-70677	LH/Dark Bronze	INSWING ARM:15-3/4:LH:313
	A-60678	LH/Clear	"INSWING ARM,9-3/4 TO 13 REV,LH,204"
	A-70678	LH/Dark Bronze	INSWING ARM:20-1/2:LH:313
14	A-60770	Clear	"ARM,OUTSWING,CU,20IN,204"
	A-70770	Dark Bronze	"ARM,OUTSWING,CU.20IN.313"
	A-60771	Clear	"ARM,OUTSWING,CU,30IN.204"
	A-70771	Dark Bronze	"ARM,OUTSWING,CU,30IN.313"
15	A-00952		SPACER, INSWING TRACK
16	A-60536	Clear	"GUIDE TRACK,C.U.,12.25L,204"
	A-70536	Dark Bronze	GUIDE TRACK,C.U.,SUB-ASSY,12.25"

Swing Arm Assemblies				
Item	Part	Finish/Sizes/Notes		Description
17	A-60639	Long/Clear		"TRACK,INSWING,10,204"
	A-70639	Long/Dark Bronze		"TRACK,INSWING,10,313"
18	A-00481	Clear		TRACK,INSWING,21 LG,204
	A-70481	Dark Bronze		TRACK,INSWING,21 LG,313
19	A-60435	Clear		"C.U. GUIDE TRACK,21.0L,204"
	A-70435	Dark Bronze		C.U. GUIDE TRACK,21.0L,313