



GT1400 Standard Single and Hurricane Single Quick Set-Up Guide

P/N C-00103 Rev 12-19-14

Nabco Entrances Inc. S82 W18717 Gemini Drive Muskego, Wisconsin 53150
Phone: (877) 622-2694 Fax: (888) 679-3319 www.nabcoentrances.com

*Associated Manuals Part Numbers: "Model GT 1400 Folding Door System Installation Manual" (P/N 15-9324)
"Wiring and Adjustment Magnum 4A Control" (P/N 15-10682)
"Acusensor 3" (P/N 15-8911-3)
"Acuvision" (P/N 15-10848)*

WARNING

- Turn OFF all power to the Automatic Door if a Safety System is not working.
- Instruct the Owner to keep all power turned OFF until corrective action can be achieved by a NABCO trained technician. Failure to follow these practices may result in serious consequences.
- NEVER leave a Door operating without all Safety detection systems operational.

Table of Contents

SECTION 1: REMOVE DRESS PLATES FROM HEADER.....	2
SECTION 2: ANCHOR PLACEMENT	2
SECTION 3: 110 VAC GENERAL WIRING	4
SECTION 4: INSTALL THE FOLDING DOOR	5
SECTION 5: GENERAL WIRING.....	8
SECTION 6: ADJUST FOLDING DOOR	9
SECTION 7: INSTALL WEATHERING.....	9
SECTION 8: TROUBLESHOOTING	10
SERVICE PARTS: HEADER	13
SERVICE PARTS: HEADER (TOP HALF).....	14
SERVICE PARTS: HEADER (BOTTOM HALF)	16
SERVICE PARTS: SINGLE FOLD DOOR.....	18
SERVICE PARTS: RIGHT HAND SINGLE FOLD DOOR.....	19
SERVICE PARTS: LEFT HAND SINGLE FOLD DOOR	20

SECTION 1: Remove Dress Plates from Header

1. Go to the non-breakout side of opening. Place Header so the Magnetic Latch is on the floor and the bottom is facing the breakout side of opening.
2. Go to the Guide Channel. Swing out the Guide Channel 90 degrees away from the Magnetic Latch.
 - a. Continue to manually hold the Guide Channel when taking off the Dress Plate and Lock Plates.

DANGER

Do not let go of the Guide Channel, it will spring back to its original location and can result in personal injury or damage.

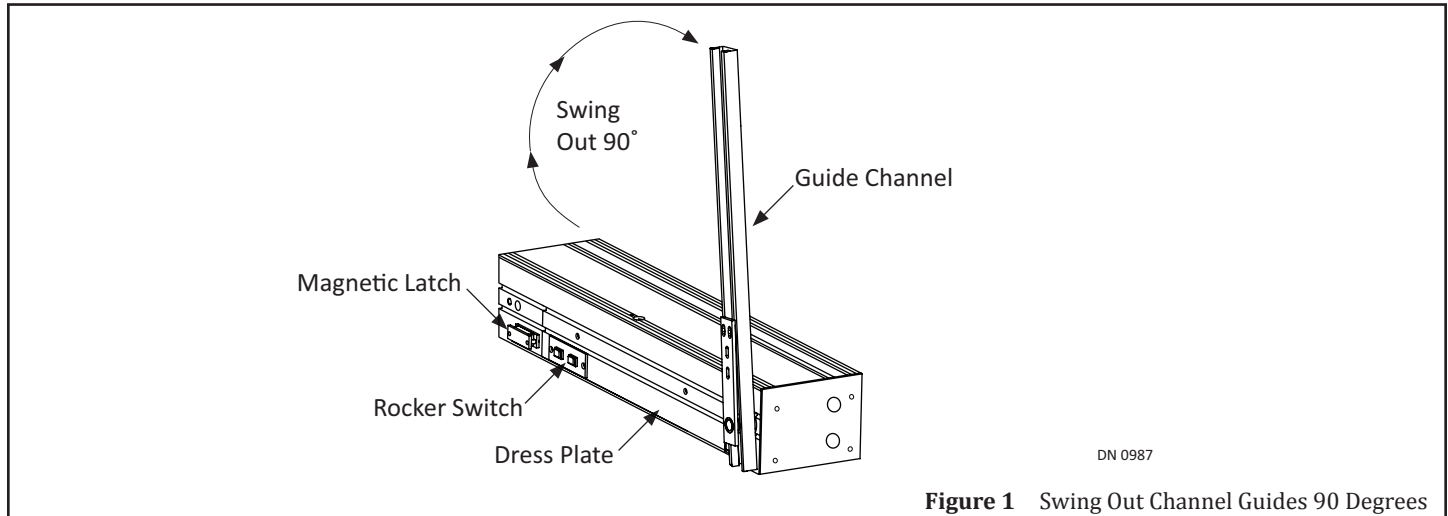

Figure 1 Swing Out Channel Guides 90 Degrees

3. Remove screws used to secure the Dress Plate.
4. Carefully lower the Dress Plate until the Rocker Switch wiring is exposed. Disconnect the Switch from the switch harness. Remove the Dress Plate and Lock Plates.
5. Manually return the Guide Channel to its original position, so that it butts up against the Magnetic Latch.

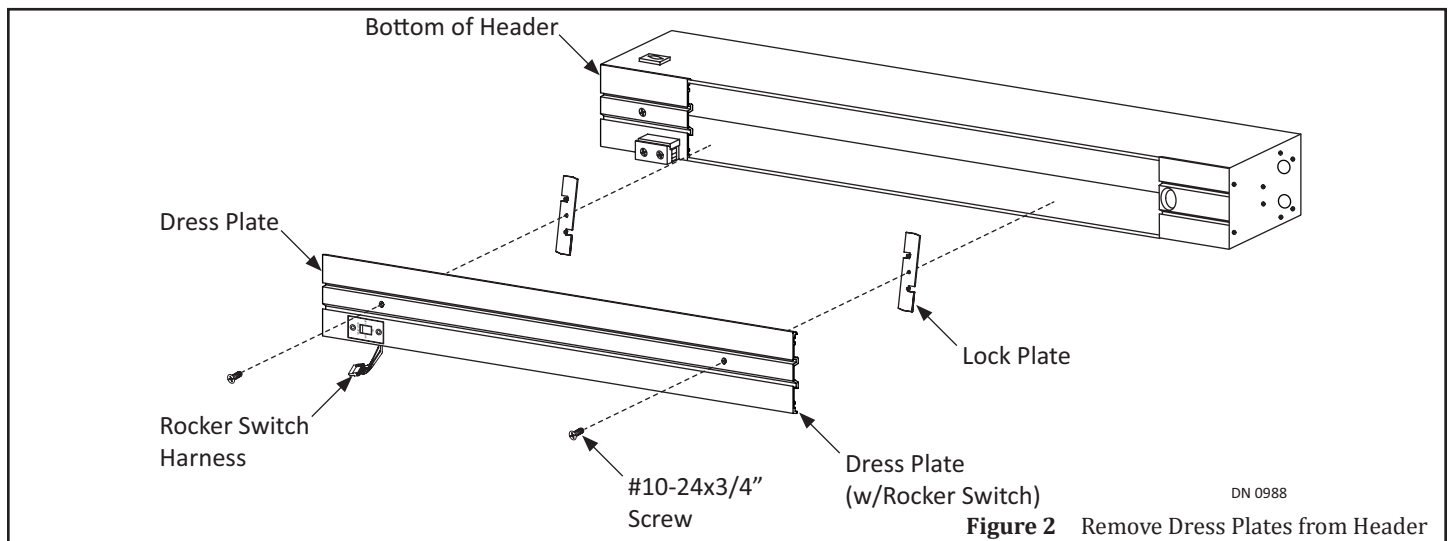

Figure 2 Remove Dress Plates from Header

SECTION 2: Anchor Placement

- ▶ Anchors are not provided by NABCO.
- ▶ Anchors must be appropriate for the type of structure being fastened to.
- ▶ Ensure anchor heads to not come in contact with edges of glass to prevent breakage.

Note: It is recommended to countersink holes as required to flush the surface.

Note: It is recommended to drill tap threads for 1/4 inch anchors in a steel or aluminum structure.

Note: If anchor points in structure are known, the aluminum door framing can be predrilled prior to installing into the opening.

Note: Do not overtighten anchors to prevent deforming Jamb tubes.

2.1 Secure Jamb Tubes to Rough Opening

1. Position Jamb tubes on either side of Header so the Weathering faces up, and the open end at the bottom of each Jamb Tube is facing the breakout side of opening.
2. Secure Jamb Tubes to Header with 1/4 inch Star Washers and 1/4-20 x 3/4 inch Bolts, provided by NABCO.

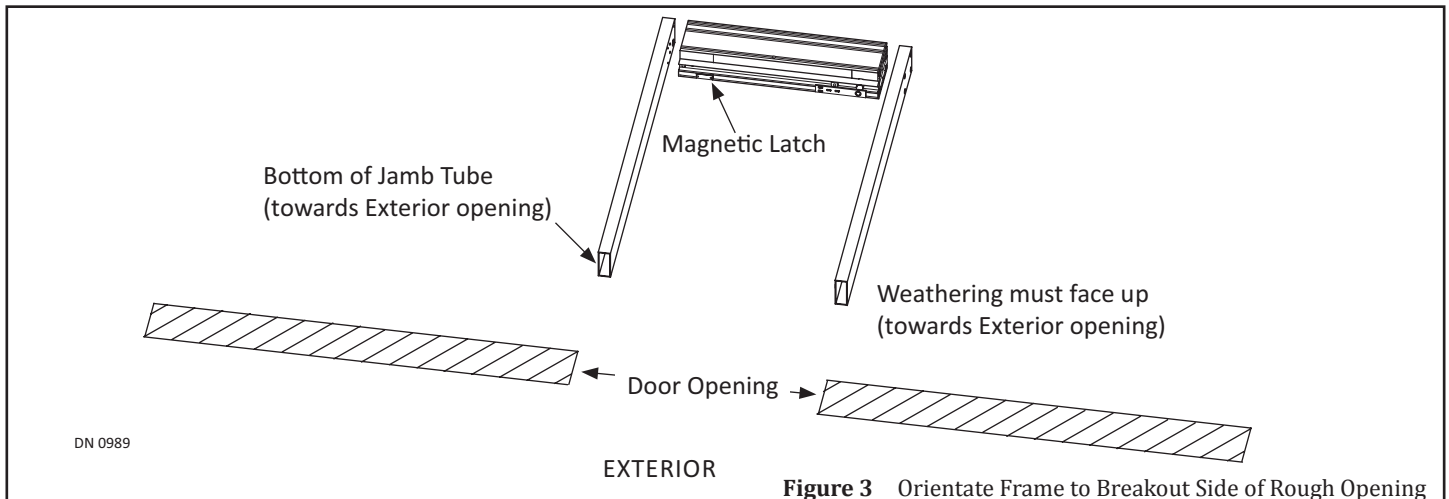

3. Lift to position the assembled Frame into the rough opening.
4. Plumb Jamb tubes in both planes to ensure the rough opening allows a 1/4 inch clearance. Shim back of Jamb as required.
5. Plumb the Header at the top to ensure the rough opening allows a 1/4 inch clearance. Shim top of Header as required.
6. Secure Jamb Tubes to Rough Opening accordingly.
 - ▶ Standard Fold Door
 - Use 1/4 inch diameter anchors with a minimum of 3 per Jamb tube, maximum is 48 inches on center. Drill 1/4 inch diameter holes in the face of Jamb and then countersink each hole. Secure with appropriate Fasteners.
 - ▶ Hurricane Fold Door
 - Screw in anchors to secure the Frame (per manufacturer's certification document(s)).

2.2 Secure Header to Rough Opening

DANGER

Verify that each Motor is connected to the Magnum 4A Control before inserting Pin or 1/8" Allen Wrench into Lovejoy Coupling Access Hole via the Access Hole on the Magnum 4A Control. Failure to do so will allow the Fold Doors to slam shut without motor braking in the event the Pin or 1/8" Allen Wrench falls out.

DANGER

Do not let go of the Guide Channel if a Pin or 1/8" Allen Wrench has not been inserted into the Lovejoy Coupling Access Hole, it will spring back to its original location and can result in personal injury or damage.

1. Ensure the Motor is connected to the Magnum 4A Control.
2. Swing the Guide Channel out and away from the Magnetic Latch. It will be necessary to manually hold the Guide Channel in the 90 degree position until the Pin or 1/8 inch Allen Wrench is inserted into the Lovejoy Coupling Access Hole.

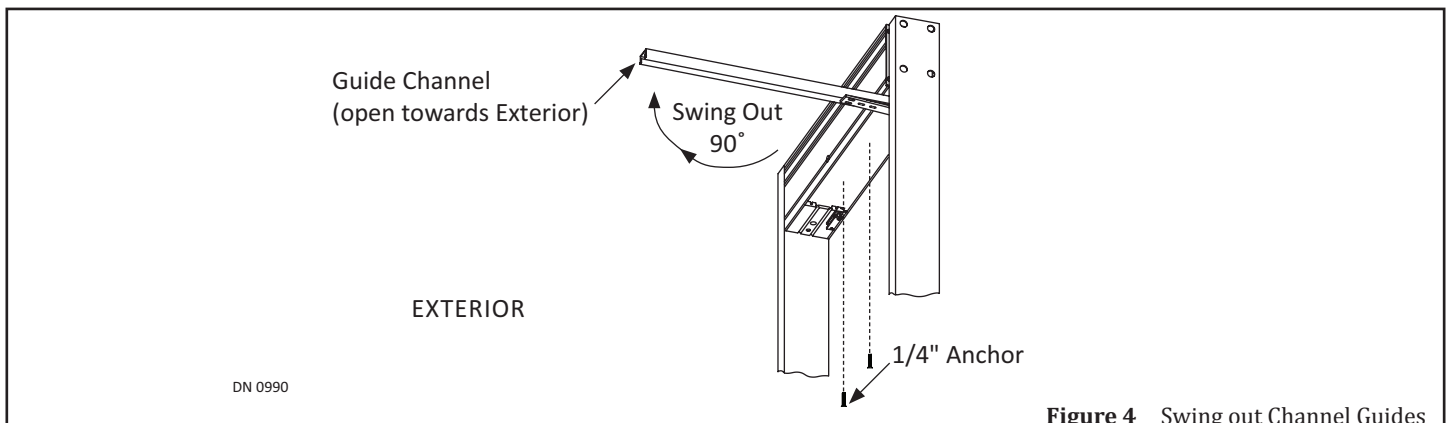

3. Locate the access hole in the Magnum 4A Control mounting bracket which leads to the Lovejoy Coupling access hole in the Operator. Insert a Pin or 1/8 inch Allen Wrench into both Access Holes.

DANGER

Do not allow the Pin or 1/8 inch Allen Wrench to drop out of the Access Hole at any time during installation. The Guide Channel will spring back to its original location and can result in personal injury or damage.

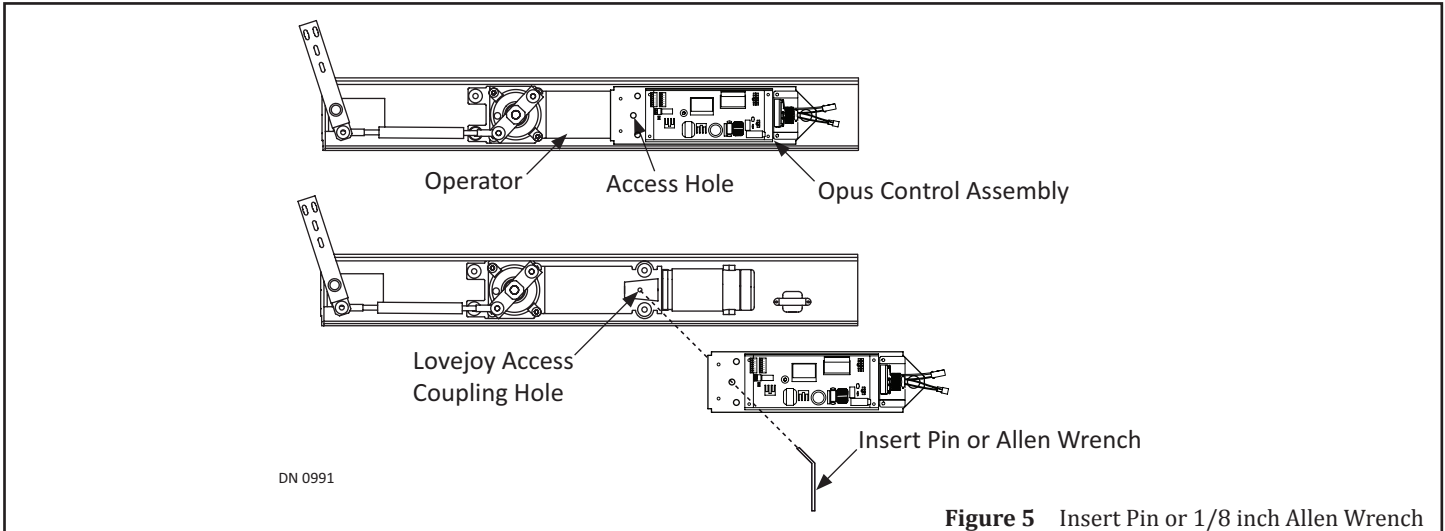

Figure 5 Insert Pin or 1/8 inch Allen Wrench

4. With the Guide Channel locked into the 90 degree open position, secure Header to the rough opening:
 - ▶ Standard Fold Door
 - Use 1/4 inch diameter anchors with a maximum 48 inches on center. First anchor maximum is 36 inches from each end of the Header. Secure with appropriate Fasteners.
 - ▶ Hurricane Fold Door
 - Screw in anchors to secure the Frame (per manufacturer’s certification document(s)).

SECTION 3: 110 VAC General Wiring

DANGER

Do not touch wires or other parts inside enclosure. Doing so may cause electrical shock, serious injury or death.

1. Disconnect Power at Fused disconnect. Verify with voltmeter.
2. Route wiring away from moving parts and other low voltage wiring.

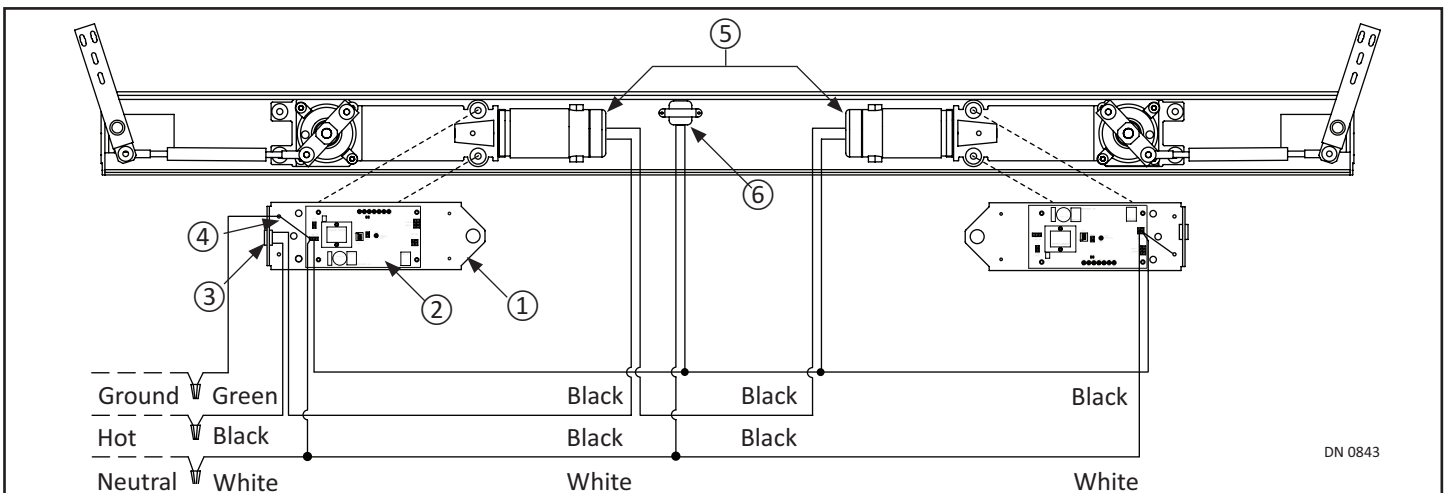

- | | | |
|------------------------------|-----------------|-------------------------|
| 1. Magnum 4A Control Bracket | 3. Power Switch | 5. Motor Thermal Switch |
| 2. Magnum 4A Control | 4. Ground Screw | 6. Transformer |

SECTION 4: Install the Folding Door

4.1 Install the Bottom Pivot (Floor Portion)

1. Obtain the Bottom Pivot Parts Box (P/N 22-9643) provided by NABCO.
 - a. (2) 1/4 - 20 round head screws provided by the Pivot Manufacturer are not required.
2. Obtain the Bottom Pivot (Floor Portion) from the Parts Box.
3. Insert the Bottom Pivot into the Notch located at the bottom of Jamb tube and then secure with (1) 1/4-20 x 7/8 inch Flat Head screw.

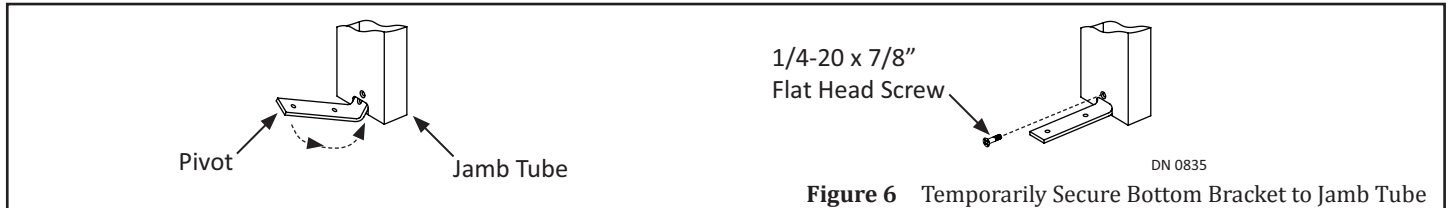

4. Using the Bottom Pivot as a template, drill down through (2) screw holes with a 1/4 inch Masonry drill bit at least 1-1/2 inches into the floor.
5. Insert (1) 1 inch Anchor into each drilled hole.
6. Obtain the Pivot Base Bracket from the Parts Box.
7. With the open end pointing to Jamb Tube, align screw holes with the Bottom Pivot (The Pivot Plate can be adjusted by sliding it in either direction).
8. Secure the Pivot Base Bracket to the Bottom Pivot and to the floor by inserting (1) #14 x 1-1/2 inch Flat Head screw into each Anchor.
9. Screw the Pivot Bearing onto the Thread Post.

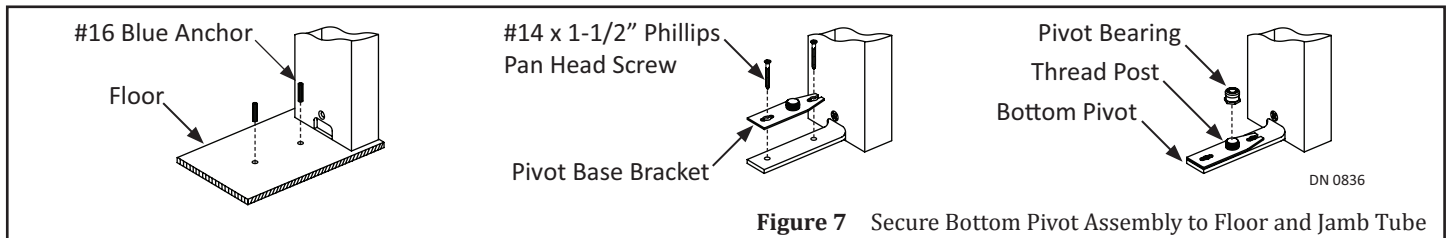

4.2 Install the Bottom Pivot (Door Portion)

1. Lay the Folding Door on a flat surface.
2. Go to the Bottom Rail. Locate (2) pre-drilled holes inside Web.
3. Lay the Bottom Pivot (Door Portion) onto the Spacer. Align screw holes to the Web.
4. Secure the Bottom Pivot to the Spacer and to the Web within the Bottom Rail with (2) 1/4 - 20 x 1-1/4" Hex Screws.

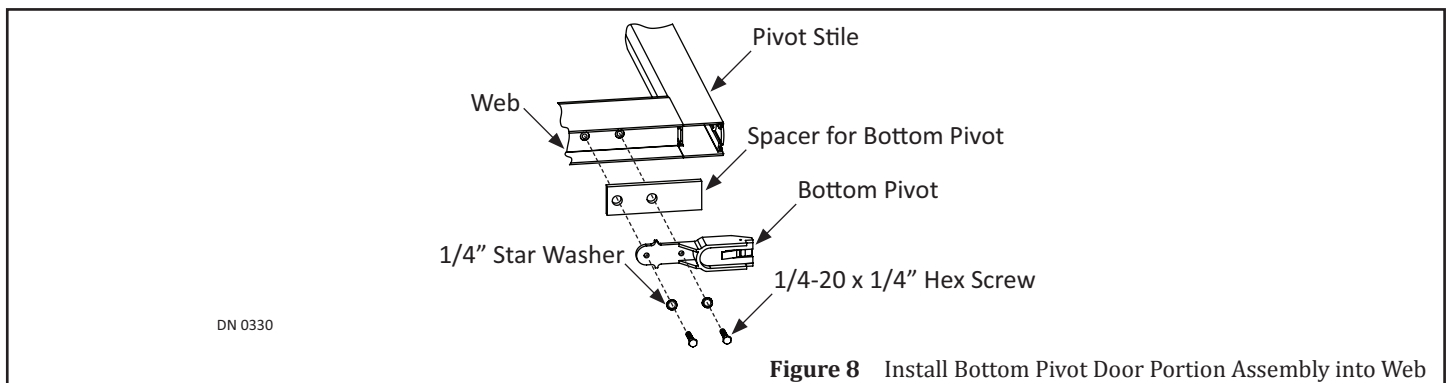

4.3 Secure Spindle Drive Bar to Folding Door

Note: The Drive Bar is installed to the Channel Guide at the NABCO Factory for shipping purposes only and must be removed from the Channel Guide before the Folding Door can be installed.

1. Ensure the Pin or 1/8 inch Allen Wrench is still inserted into the Lovejoy Coupling Access Hole.

2. Go to the Spindle Drive Bar. Remove the Hex Bolt and Nut.
 - a. Please refer to the Shipping Sticker located on the Spindle Drive Bar.
3. Release the Spindle Drive Bar from the Guide Channel.
 - a. The Spindle Drive Bar can be pushed up toward the Header or down into the Top Web of the Folding door, but will remain at a 90 degree angle.
 - b. The Guide Channel can now freely swing closed or open.
4. Swing the Guide Channel up against the Magnetic Latch.

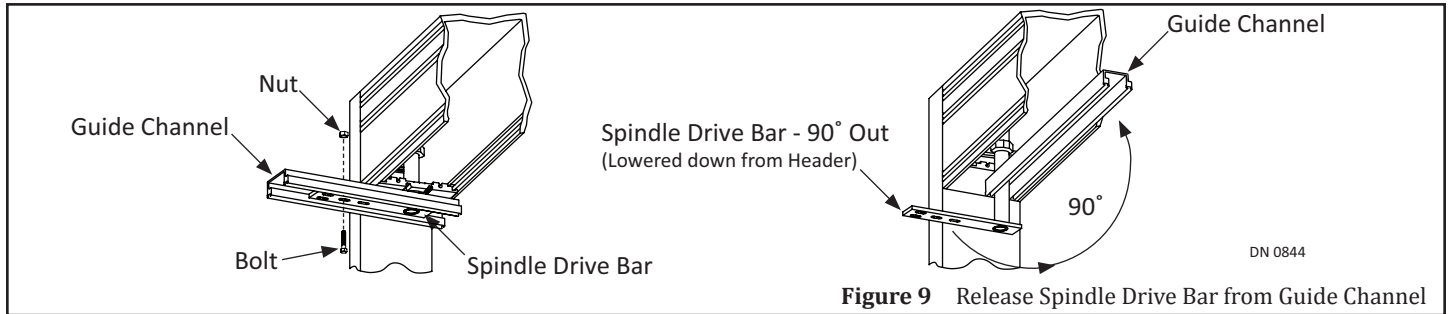

Figure 9 Release Spindle Drive Bar from Guide Channel

4.4 Secure Folding Door to Frame

1. With the Folding Door still on a flat surface, go to the Pivot End of the Top Web.
2. Remove (4) 1/4-20 x 3/4 inch Hex Head Screws and (4) 1/4 inch Star Washers from Riv-nuts located inside the Web. Save hardware for reinstallation.

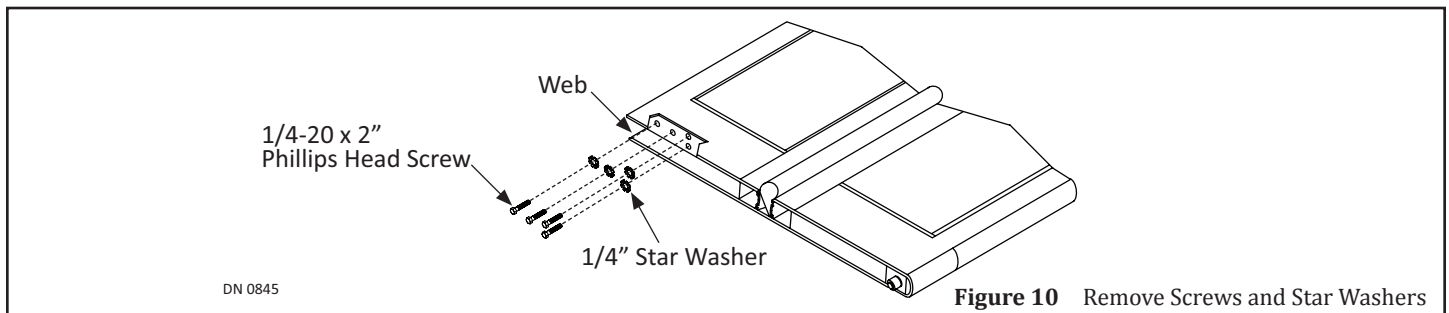

Figure 10 Remove Screws and Star Washers

3. Lift the Folding Door from the flat surface. Keep Door Panels loosely folded.
4. Tilt the Folding Door to slide the Spindle Drive Bar into the Pivot end of Top Web. The Spindle Drive Bar can be pushed up toward the Header to allow clearance.
5. Upright the Folding Door to slide the Bottom Pivot onto the Pivot Bearing located inside the Bottom Rail.
6. Go back to the Top Web. Lower the Spindle Drive Bar until it butts up against the Web.
7. Secure the Spindle Drive Bar to the Web with (4) 1/4-20 x 3/4 inch Hex Head Screws and (4) 1/4 inch Star Washers that were saved for reinstallation.
 - a. Do not tighten down bolts at this time. Bolts need to be loose enough to allow the Folding Door to be adjusted.

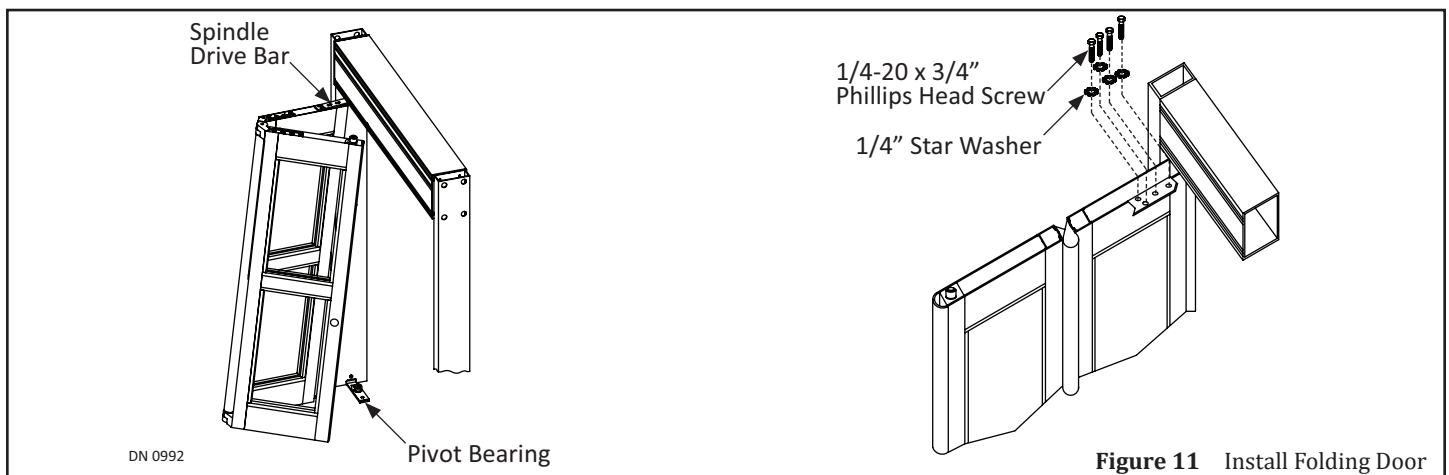
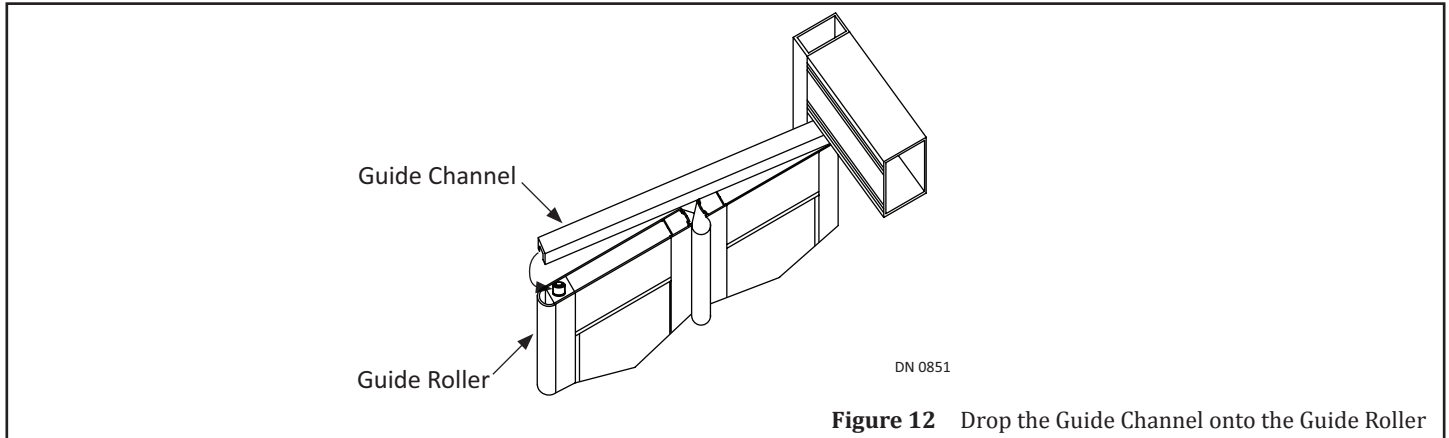

Figure 11 Install Folding Door

4.5 Secure Guide Channel to Folding Door

1. Manually hold open the Folding door while removing the Pin or 1/8 inch Allen Wrench from the Lovejoy Coupling Access Hole.
2. Swing out and then lift the Guide Channel so it is directly on top of the Guide Roller located inside the Top Web at the Strike end. Drop the Guide Channel onto the Guide Roller. Allow the Folding door to close without slamming closed.



3. Adjust Door Panels so the gaps around the Top, Bottom, and Sides are parallel to the Jamb Tubes, Header, and Threshold.
 - a. Adjustments can be done using the Top Pivot Bracket and Bottom Pivot Bearing.
4. Tighten down the (4) 1/4-20 x 3/4 inch Hex Head screws and (4) 1/4 inch Star Washers.

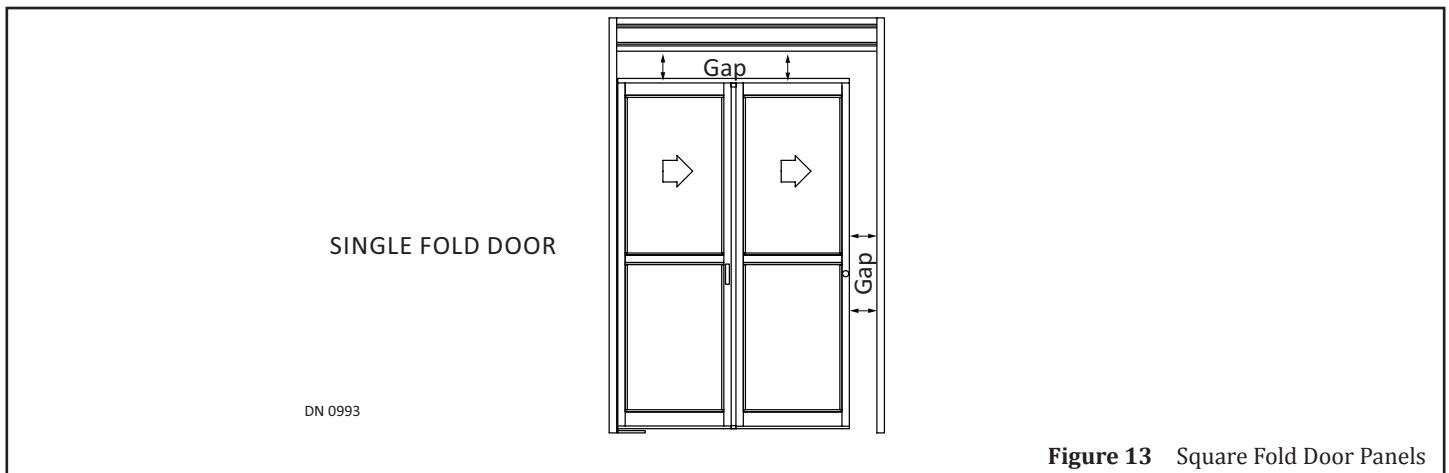

5. Push on the Bar located in the middle of Bi-Fold Panels to manually fold open the Door.
6. Go to the Spindle Drive Bar located inside the Top Web, at the Pivot end.
7. Obtain (1) Split Plastic Bushing that was provided by NABCO.
8. Push the Split Plastic Bushing around the Spindle between the Guide Channel and Spindle Drive Bar.

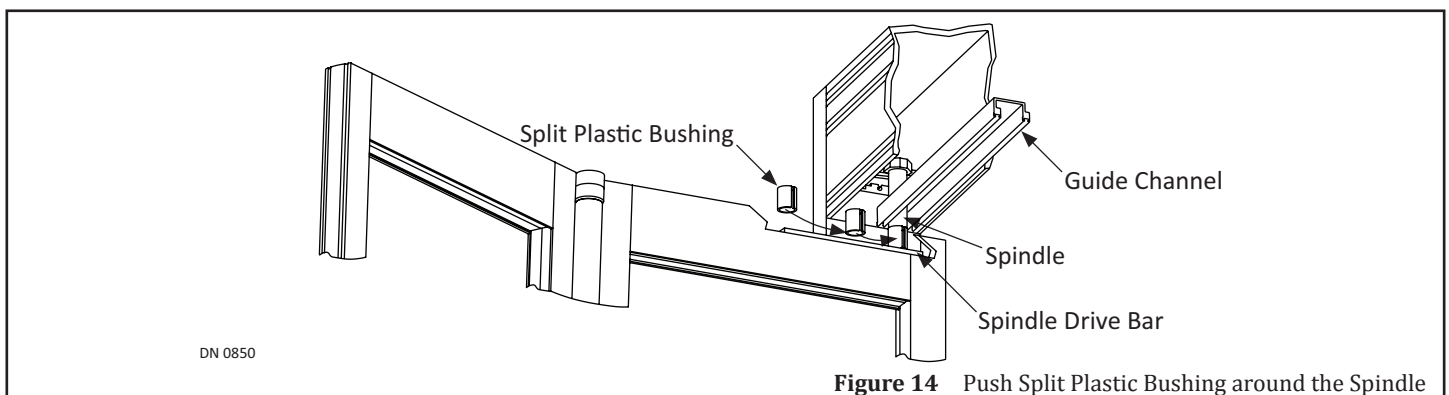

SECTION 5: General Wiring

5.1 GT-1400 Single Fold with One Magnum 4A Control

- NOTES:**
1. WIRES AT SENSOR CONNECTORS AND SWITCH CONNECTORS IN THIS DRAWING DO NOT REPRESENT THE ORDER OF THE WIRES AT THAT CONNECTOR.
 2. SENSORS OR OTHER ACTIVATION DEVICES MUST USE NORMAL OPEN DR. CONTACTS FOR TRIGGERING

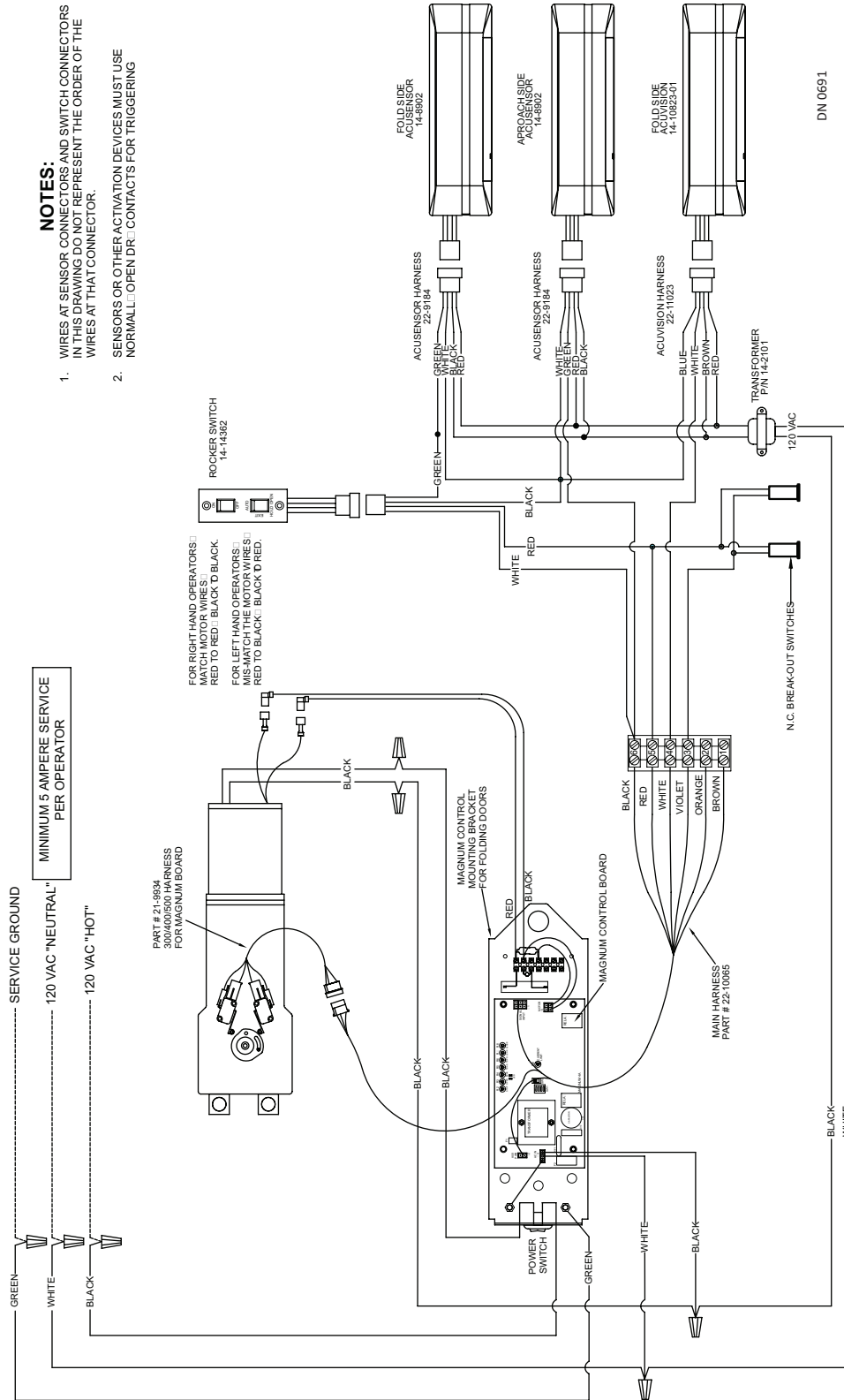

DN 0691

SECTION 6: Adjust Folding Door

Note: Each Push Rod has been pre-installed at the NABCO Factory to ensure the Folding door will fully close under normal operation. However, after installation, adjustments may be necessary.

1. Go to the Push Rod that needs to be adjusted. Loosen both Hex Locknuts.
 - a. One Hex Locknut has left hand threads, the other Hex Locknut has right hand threads.
2. Turn the Push Rod clockwise or counterclockwise to lengthen or shorten the Push Rod until the Folding Door can fully close with both door panels flat.
 - a. One end of each Push Rod has left-hand threads; the other end has right hand threads.
3. Re-tighten both Hex Locknuts. Do not overtighten.

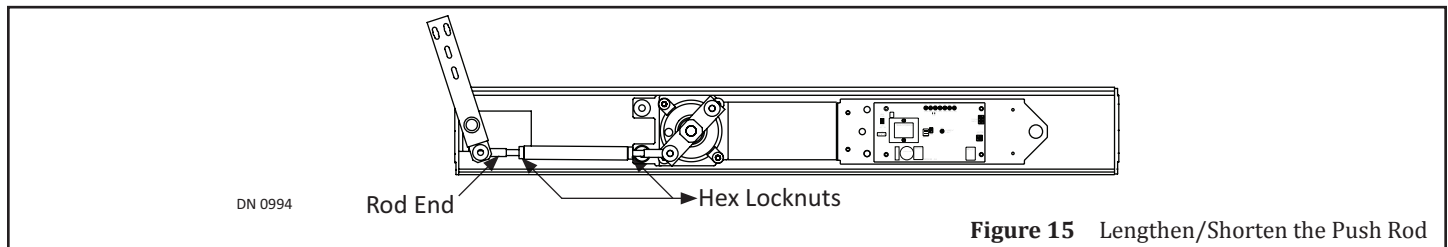

SECTION 7: Install Weathering

Note: Weathering Extrusions are pre-installed with brush at the NABCO Factory.

Note: Weathering Extrusions are bent at the NABCO Factory to fit the shape of the Door Hinge.

1. Go to the Outside bottom of the door.
2. Position the Weathering Extrusion so the bent portion lays on top of the Door Hinge.
3. Secure the weathering brush to Folding door panels with #6 x 1/2 inch self tapping, color matched screws.

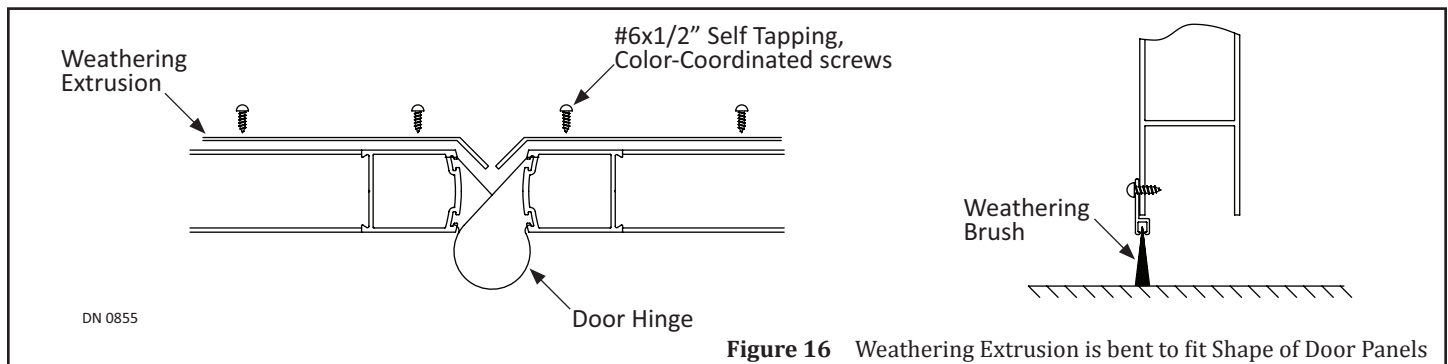

SECTION 8: Troubleshooting

Magnum 4A Troubleshooting Chart		
Problem	Solution	
Operator does not function	Cause	Fuse 1 (F1) may be blown.
	Resolution	Replace Fuse.
	Cause	Fuse installed on Brake Module may be blown.
	Resolution	Test and Replace Fuse.
	Cause	No incoming power.
	Resolution	Ensure 120 VAC incoming power is connected.
	Cause	J5 Motor circuit may not be properly connected.
	Resolution	<ol style="list-style-type: none"> 1. Go to J5 Motor Feed. 2. Check connections to Pin (1) and Pin (2) and also both Motor Leads connected to brake module. 3. Replace motor if necessary.
	Cause	Current consumption overload.
	Resolution	<ol style="list-style-type: none"> 1. Go to Terminal Block. 2. Check current consumption at Terminals 1 & 2. 3. If current draw exceeds 0.5 amps at 24 VAC, disconnect auxiliary devices such as sensors from Terminals 1 and 2 and install an alternate power supply such as a Transformer.
	Cause	Motor may be blown.
	Resolution	Replace motor.
Door slams closed	Cause	Closing speed on Magnum control needs adjustment.
	Resolution	<ol style="list-style-type: none"> 1. Go to CLOSE Potentiometer. Operation should continue as soon as recycling is done. 2. Turn counterclockwise to decrease closing speed.
	Cause	Motor circuit may be open.
	Resolution	<ol style="list-style-type: none"> 1. Go to J5 Motor Feed. 2. Check connections on Pin (1) and Pin (2).
	Cause	Latch Check may be set too high.
	Resolution	<ol style="list-style-type: none"> 1. Go to LCHK Potentiometer. 2. Turn counterclockwise to decrease speed.
Door slams open	Cause	Back Check may be set too high.
	Resolution	<ol style="list-style-type: none"> 1. Go to BCHK Potentiometer on Magnum 4A Control board. 2. Turn counterclockwise to decrease speed.
	Cause	Operator may not be correctly preloaded.
	Resolution	Pre-load operator by correctly installing arm on operator spindle per hardware installation manuals.

Magnum 4A Troubleshooting Chart		
Problem	Solution	
Fuse 1 (F1) or Fuse 2 (F2) blows when OPEN Potentiometer is activated	Cause	Current consumption overload.
	Resolution	<ol style="list-style-type: none"> 1. Go to Terminal Block. 2. Check current consumption at Terminals 1 & 2. 3. If power exceeds 0.5 amps at 24 VAC, disconnect auxiliary devices such as sensors from terminals 1 and 2 and install an alternate power supply such as a transformer.
Motor spins when activated but door does not open.	Cause	Motor connected backwards.
	Resolution	Reverse motor leads on motor.
	Cause	Motor/Operator coupling or spider coupling loose between motor and operator.
	Resolution	<ol style="list-style-type: none"> 1. Remove motor and operator from Header. 2. Separate motor from operator. 3. Inspect couplings for looseness.
Back Check adjustment on Magnum 4A has no effect.	Cause	Door is not going into Back Check at 80 ° position.
	Resolution	<ul style="list-style-type: none"> ● Pre-load operator by correctly installing arm on operator spindle per Hardware Installation manuals
No Back Check.	Cause	Back Check switch may not be closing at correct position.
	Resolution	Pre-load operator by correctly installing arm on operator spindle per Hardware Installation manuals
Door does not stay tightly closed.	Cause	Preload may not be correct.
	Resolution	Pre-load operator by correctly installing arm on operator spindle per hardware installation manuals.
Safety Sensor does not function.	Cause	No power to sensor.
	Resolution	Check wiring on harness and power to sensor.
	Cause	Sensor may not be properly connected to Terminal Block.
	Resolution	<ol style="list-style-type: none"> 1. Go to Terminal Block. 2. Connect the output of sensor to: <ul style="list-style-type: none"> ● Header mounted sensor: Terminals 5 (Red) and Terminal 4 (White) ● Door mounted sensor: Terminals 5 (Red) and Terminal 3 (Violet).
	Cause	Dip Switch (2) Safety may be Off instead of On or vice versa.
	Resolution	<ul style="list-style-type: none"> ● Sensors using N.O. Contacts, turn Dip Switch ON. ● Sensors using N.C. Contacts, turn Dip Switch OFF.
Header mounted Swing Side Presence Sensor is activated by opening or closing door.	Cause	Connection of Sensor to Terminal Block was to "Continuous Safety" not "Safety w/ Lockout".
	Resolution	<ol style="list-style-type: none"> 1. Rewire Safety Sensor to "Safety w/Lockout". 2. Go to Terminal Block. 3. Connect the output of the Sensor to Terminal (5) Red Wire and Terminal (4) White Wire.

Magnum 4A Troubleshooting Chart		
Problem	Solution	
Sensor, safety mats, holding beams, or all other accessories mounted on swing side of door do not function while door is moving.	Cause	Connection of Sensor to Wiring harness to: "Safety w/Lockout" not "Continuous Safety".
	Resolution	<ol style="list-style-type: none"> 1. Rewire Safety Sensor to "Continuous Safety". 2. Go to Terminal Block. 3. Connect output of the Sensor to Terminal (5) Red Wire and Terminal (3) Violet Wire.
Sensor shows activation signal was sent; door does not open.	Cause	Sensor not properly connected activation circuit.
	Resolution	Check wiring on harness.
	Cause	Safety signal preventing door from opening.
	Resolution	Correct cause of safety signal.
One sensor does not activate both doors on a simultaneous pair.	Cause	Sensor is not connected to both control boards.
	Resolution	Install simultaneous pair harness (P/N 22-9953).

SERVICE PARTS: HEADER

Viewed from *Non-Break* Out Side

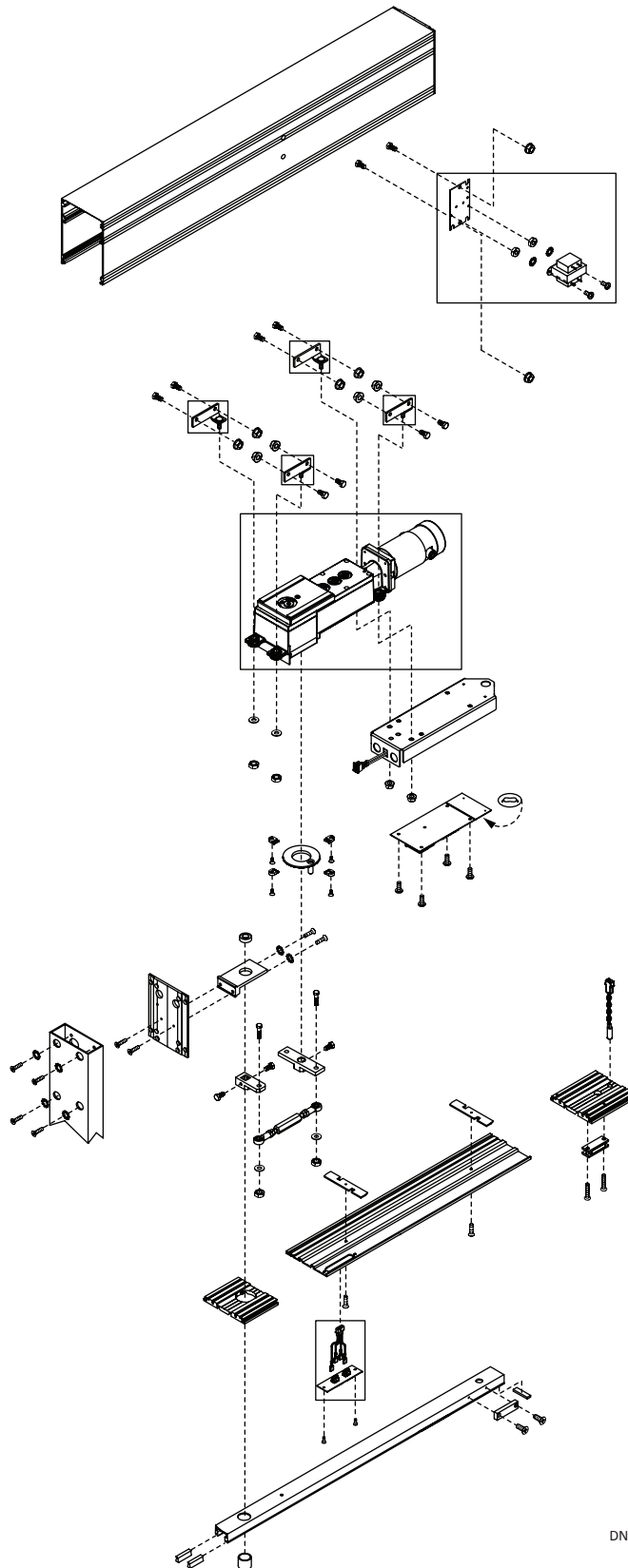

DN 0995

SERVICE PARTS: HEADER (TOP HALF)

Viewed from *Non-Break* Out Side

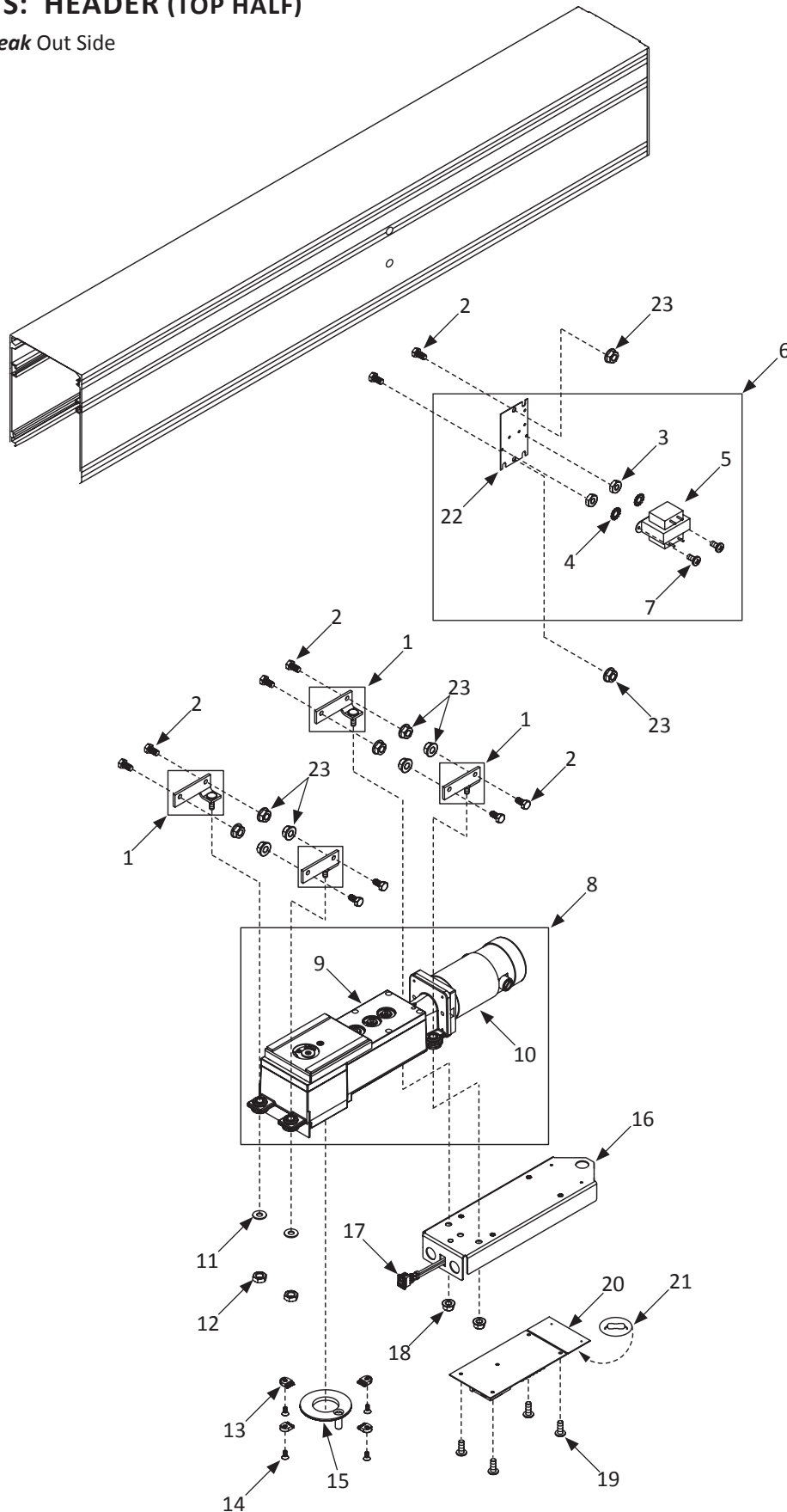

DN 0997

Header (Top Half)			
Item	Part	Added Information	Description
1	21-8920	RH	OPERATOR MOUNT WELDMENT RH BIFOLD
	21-8921	LH	OPERATOR MOUNT BIFOLD, LH
2	24-0014-14		HHCS,5/16-24 X 5/8
3	24-0021-04		HEX NUT #10-24
4	24-0019-18		WASHER,EXT.#8
5	14-2101-01		TRANSFORMER ONLY, 24 VOLT - 40 VA
6	14-2101		TRANSFORMER W/BRACKET, 24 VOLT - 40 VA
7	10-0617		SCREW - 10-24 X 3/8 PHIL PAN S.S.
8	41-8987-15	LH	BI FOLD OPERATOR ASSY LH-MAGNUM
	41-8987-16	RH	BI FOLD OPERATOR ASSY RH-MAGNUM
9	24-10920-15	LH	BI FOLD GB LH-MAGNUM
	24-10920-16	RH	BI FOLD GB RH-MAGNUM
10	22-0575		MOTOR & COUPLING SUB-ASSY - SWINGER
11	24-0017-02		WASHER, 7/16 ID X 1 OD X .083 THK
12	24-0021-15		HEX JAM NUT 3/8"-16
13	24-2303		STOP RING HOLD DOWN
14	24-0011-23		FHMS,5/16"-18 X 3/4, SKT,ZINC
15	21-0700		CU - LIMIT STOP
16	24-14233		BRACKET, MAGNUM, BIFOLD
17	14-10585		POWER SWITCH ASSEMBLED - SWINGERS / 710
18	24-0021-21		NUT, WHIZLOCK, 3/8-16, ZN
19	24-0012-14		PHMS, #10-32 X .50 LG, PHL, ZINC
20	24-9800-04 A		MAGNUM CONTROL BOARD-04 Rev-A
21	12-13166		3 AMP FUSE W/ HEAT SHRINK
22	24-10679-02		PLATE TRANSFORMER & RELAY MTG TELESCOPIC
23	24-0021-34		NUT, WHIZLOCK, 5/16-24, ZINC

SERVICE PARTS: HEADER (BOTTOM HALF)

Viewed from *Non-Break* Out Side

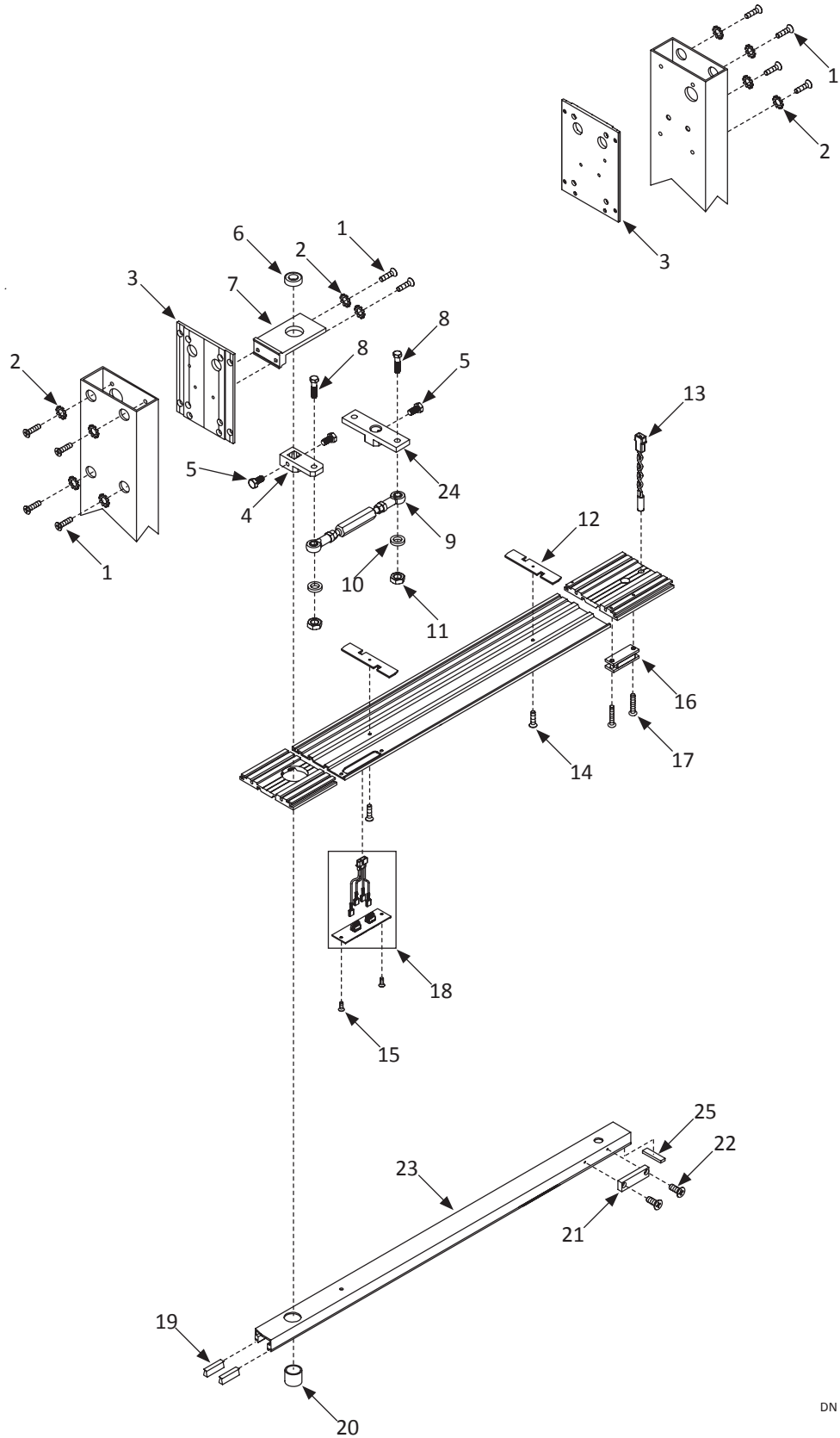

DN 0998

Header (Bottom Half)			
Item	Part	Added Information	Description
1	24-0014-02		HHCS, 1/4-20 X 3/4", ZN
2	24-0019-05		1/4" EXTERNAL STAR WASHER
3	22-9694		BIFOLD, HEADER END CAP ASSY NH
4	14-8985		BELL CRANK, SPINDLE
5	24-0014-14		HHCS,5/16-24 X 5/8
6	24-0413		BEARING, BALL
7	11-8968		UPPER SPINDLE GUIDE SUB-ASSY
8	24-0014-33		HHCS,3/8-24 X 1 1/2
9	21-5898		PUSH ROD ASSY, SGL FOLD
10	24-0667-01		SPACER, MOUNTING - END CAP-UL PART
11	24-0021-29		NUT,HEX,NYLOCK 3/8-24-UL PART
12	24-1849		LOCK COVER PLATE - BOTTOM
13	22-9222		BREAK OUT SW ASSY FULL OPN & PKTD GT1175
14	24-0011-01		FHMS,10-24 X 3/4,PHILLIPS
15	24-0011-104		FHMS,10-32 X 1/2", UND, BLK OX
16	11-9363		KIT BIFOLD MAGNETIC LATCH RETROFIT
17	24-0015-63		RHMS,#10-24 X 1 1/4"PHIL.SS
18	14-14362-00	No Logo	RKR SW ASSY BI-FOLD/MAG,BLANK
	14-14362-01	NABCO Logo	RKR SW ASSY BI-FOLD/MAG,NABCO LOGO
	14-14362-02	Porta Service Logo	RKR SW ASSY BI-FOLD/MAG,PORTSERV LOGO
19	14-2279-05		PILE WEATHERING, BLK, .45 TALL, W/ ADHES
20	14-8990		BEARING, SLEEVE
21	14-8964		BLOCK, LATCH - MAGNETIC
22	24-0011-03		FHMS,10-24 X 1/2", PHIL, ZN
23	24-8972-01	LH/Clear	GUIDE CHANNEL LH
	24-8972-02	LH/Dark Bronze	GUIDE CHANNEL LH
	24-8973-01	RH/Clear	GUIDE CHANNEL RH 204
	24-8973-02	RH/Dark Bronze	GUIDE CHANNEL RH 313
24	24-8976		ARM, BELL CRANK, BIFOLD OPERATOR
25	14-8413-02		FLEXIBLE MAGNETIC STRIP

SERVICE PARTS: SINGLE FOLD DOOR

Viewed from *Non-Break* Out Side

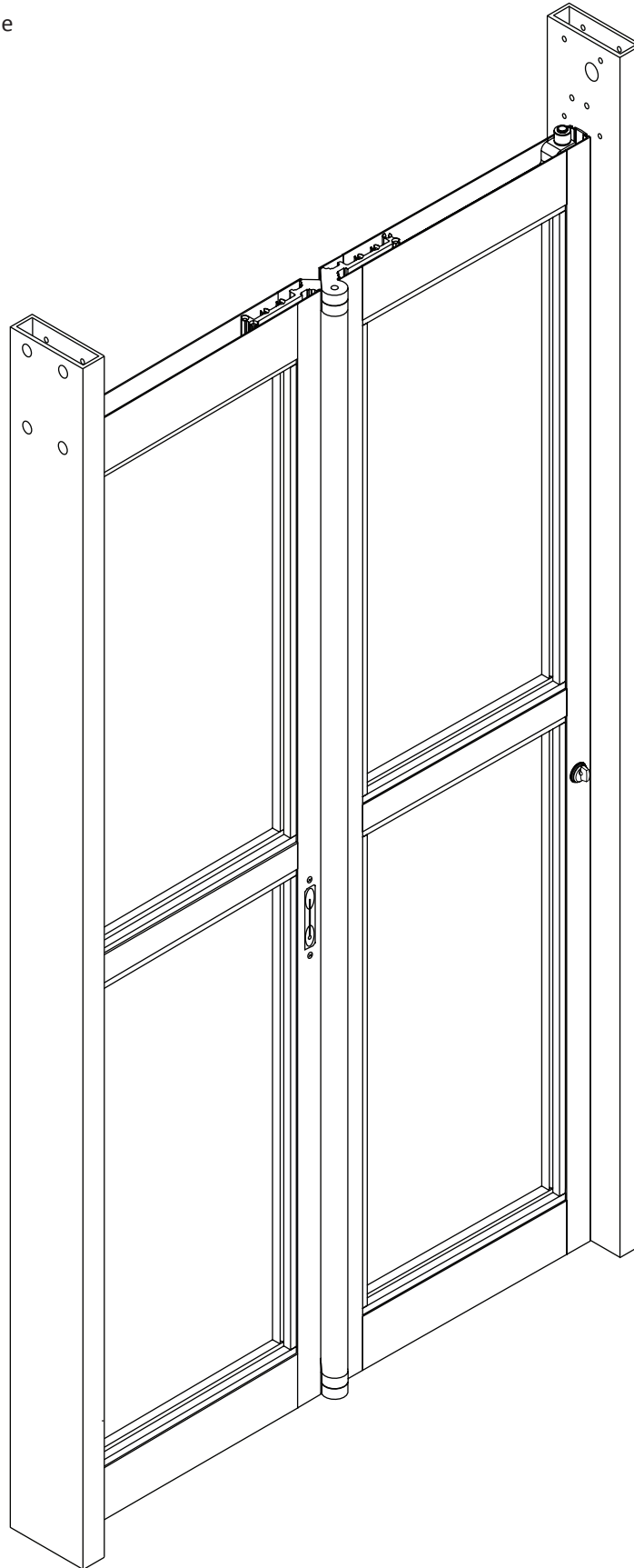

DN 0996

SERVICE PARTS: RIGHT HAND SINGLE FOLD DOOR

Viewed from **Non-Break** Out Side

- * Sold in Parts Bag; P/N 22-9643
- ** Bottom Lock Rod Used on Hurricane Doors Only

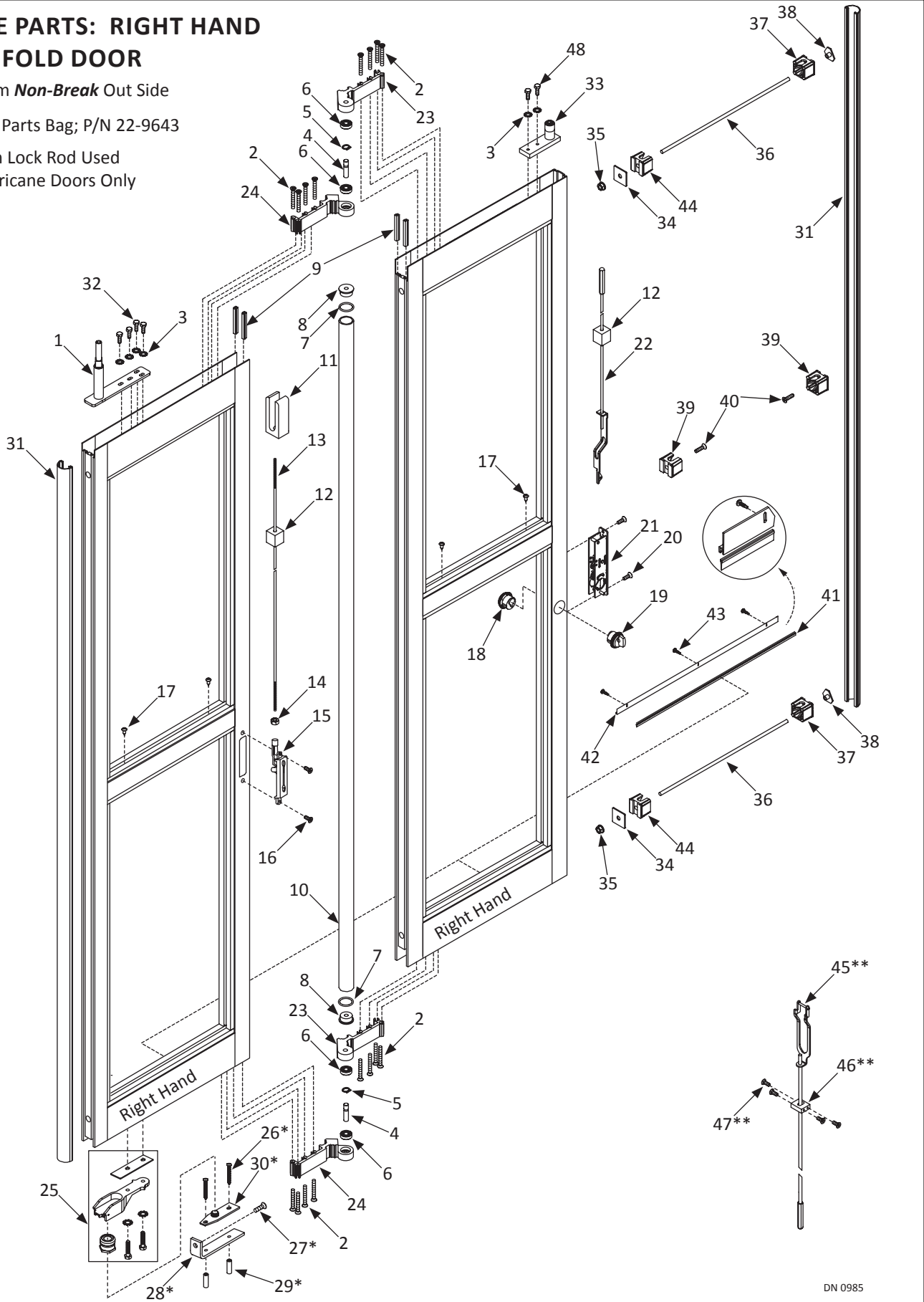

DN 0985

SERVICE PARTS: LEFT HAND SINGLE FOLD DOOR

Viewed from *Non-Break* Out Side

* Sold in Parts Bag; P/N 22-9643

** Bottom Lock Rod Used on Hurricane Doors Only

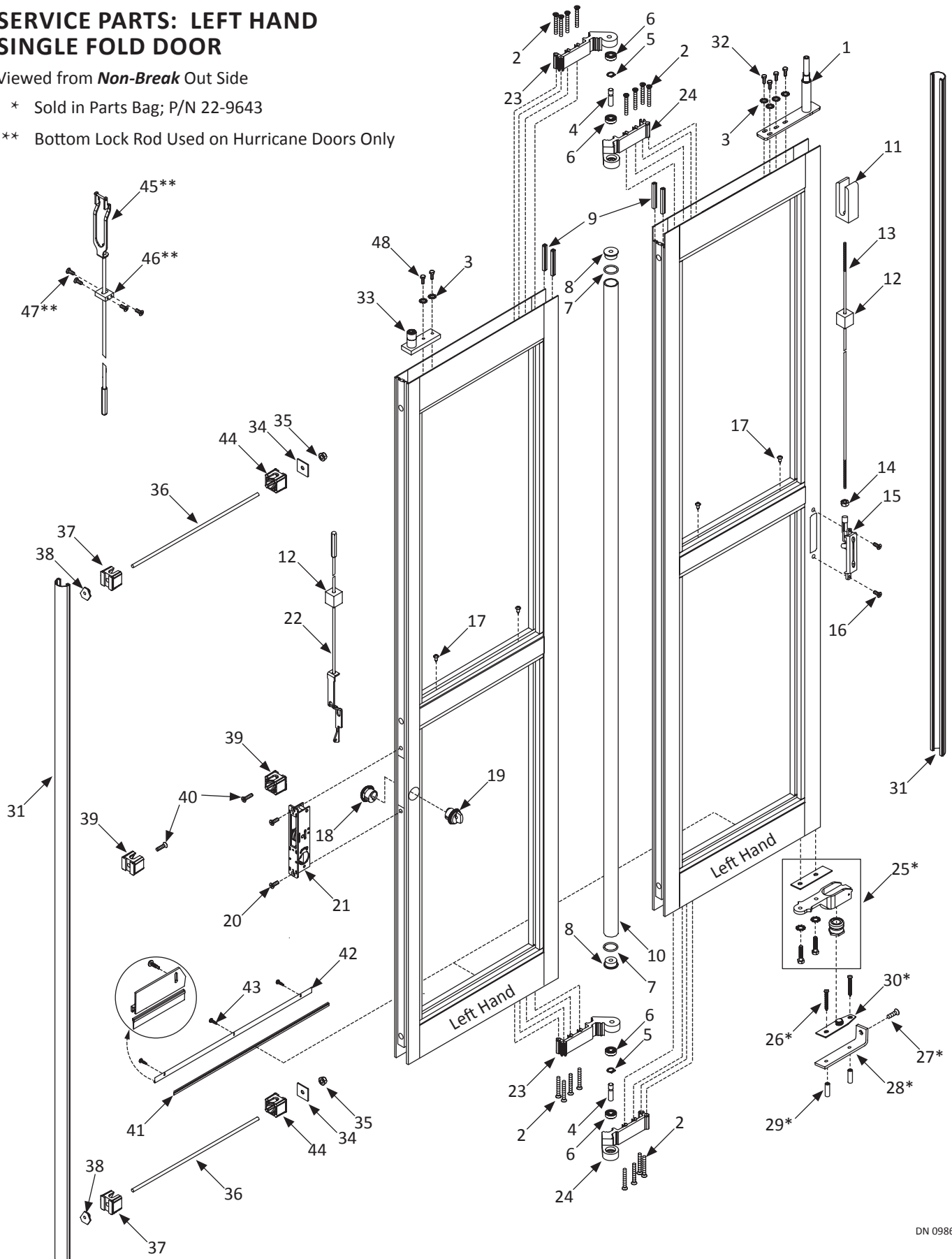

DN 0986

Single Fold Door			
Item	Part	Added Information	Description
1	22-8971		DRIVEBAR WLDMNT NH COMP W/8969-8970 BIFD
2	24-0011-10		FHMS,1/4-20 X 2,PHILLIPS
3	24-0019-05		1/4" EXTERNAL STAR WASHER
4	14-8956		PIN, HINGE FATIGUE PROOF, COLD FINISHED
5	24-1193-16		RING, SHAFT 0.394 DIA EXTERNAL SERIES
6	24-0414		BEARING, BALL
7	14-12950		O-RING, 1.50 OD X 1.25 ID, EPDM
8	14-8947		END PLUG, HINGE TUBE
9	14-2279-05		PILE WEATHERING, BLK, .45 TALL, W/ ADHES
10	24-8958-01	Clear	HINGE TUBE, 6.58'
	24-8958-02	Dark Bronze	HINGE TUBE, 6.58'
11	24-8937		LOCK BOLT - PIVOT PANEL
12	14-9358		ANTI-RATTLE - FOAM BLOCK 1.5 X 1.5
13	24-8949		LOCK ROD, FOR FLUSH BOLT - 3.38'
14	24-0021-14		HEX NUT, 1/4-20, ZN
15	24-8948-01		FLUSH BOLT KAWNEER - RD FACE
16	24-0011-72		FHMS,10-24 X 3/8", PHIL, UND
17	24-0094-01		PHSMS, 10 X 1/2", PHIL, TYPE A
18	22-4495-01	Silver	KEYED ALIKE LOCK CYLINDERS SILVER
19	22-0090-01	Silver	CYLINDER, THUMB TURN SILVER
	22-0090-02	Bronze	CYLINDER, THUMB TURN BRONZE
20	24-0011-84		FHMS,8-32 X 1/2,PHIL
21	14-2046-03		FLUSH BOLT W/O FACEPLATE
22	22-4412		HEADER LOCK ROD ASSY LESS SCREW PACK
23	24-8923-01	RH	CENTER HINGE, MACHINED- RH
	24-8923-02	RH	CENTER HINGE, MACHINED-RH
24	24-8924-01	LH	CENTER HINGE, MACHINED-LH
	24-8924-02	LH	CENTER HINGE, MACHINED-LH
25	22-9643		FLOOR PIVOT ASSY BIFOLD
26	24-0094-07		SCREW, PHLLPS PAN HD MACH 6 X 1" AB
27	24-0011-107		FHMS, 1/4-20 X 7/8", PHIL, ZN
28	24-9642		BRACKET, PIVOT BASE
29	14-1018		ANCHOR - PLASTIC #14 X 1 BLUE
30	24-9641		SPACER, PIVOT
31	14-9705-01		WEATHER STRIP BULB, BLACK IN BULK
32	24-0014-02		HHCS, 1/4-20 X 3/4", ZN
33	22-8939		NOSE GUIDE ASSY - BIFOLD
34	14-9225		BACKING PLATE, TIE ROD - DOOR ASSEMBLY
35	24-0021-21		NUT, WHIZLOCK, 3/8-16, ZN

Single Fold Door			
Item	Part	Added Information	Description
36	14-3624		THREADED ROD, 3/8"-16 - ZINC PLATED
37	24-9504		CLIP, MUNTIN BAR - RAIL .386 HOLE
38	14-9279		OFFSET TEE NUT, 3/8"-16
39	24-9502		CLIP, MUNTIN BAR - RAIL .261 HOLE
40	24-4941-02		FHMS, 1/4-20 X 1", PHIL, TRILOBE, ZN
41	14-4899-40		BRUSH, WTHRING-.006, BRISTENYLON A.44, B
42	14-5636-01		EXTRUSION, ALUM - WEATHERING, FLAT
43	24-0013-04		PHSMS, 6 X 1/2", PHIL, TEKS, BLK ZN
44	24-9503		CLIP, MUNTIN BAR - RAIL .500 HOLE
45	22-10256	Hurricane Doors Only	LOCK ROD, SUB ASSY. 7 FT LENGTHS
46	14-10233	Hurricane Doors Only	UPPER LOCK GUIDE - HURRICANE UNIT
47	24-0011-131	Hurricane Doors Only	FHMS, 10-32X1/2", PHIL, TYP 23, UND, ZN
48	24-0010-16		SHCS, 1/4-20 X 1 1/4"