



GT2150 Full Open w/Track Telescopic Slide Door
Quick Set-Up Parts Guide
P/N 15-12499-011 Rev 12-19-14

Nabco Entrances Inc. S82 W18717 Gemini Drive Muskego, Wisconsin 53150
Phone: (877) 622-2694 Fax: (888) 679-3319 www.nabcoentrances.com

*Associated Manuals Part Numbers: Architectural Specifications Manual
"GT 2150 Manual Slider Installation Manual" (P/N 15-12941)*

WARNING

- Turn OFF all power to the Automatic Door if a Safety System is not working.
- Instruct the Owner to keep all power turned OFF until corrective action can be achieved by a NABCO trained technician. Failure to follow these practices may result in serious consequences.
- NEVER leave a Door operating without all Safety detection systems operational.

Table of Contents

1 INSTALL FRAME 2

2 POSITION THE FLOOR TRACK 2

3 INSTALL THE SWING SIDELITE PANEL 3

4 ADJUST THE BALL DETENTS 4

5 INSTALL THE TRAIL DOOR 5

6 INSTALL THE LEAD DOOR 5

7 SECURE THE FLOOR TRACK 5

8 ADJUSTMENTS 6

SERVICE PARTS: HEADER 8

SERVICE PARTS: SIDELITE 10

SERVICE PARTS: RIGHT HAND SIDELITE 11

SERVICE PARTS: LEFT HAND SIDELITE 12

SERVICE PARTS: TRAIL DOOR 14

SERVICE PARTS: RIGHT HAND TRAIL DOOR 15

SERVICE PARTS: LEFT HAND TRAIL DOOR 16

SERVICE PARTS: LEAD DOOR 19

SERVICE PARTS: RIGHT HAND LEAD DOOR 20

SERVICE PARTS: LEFT HAND LEAD DOOR 21

1 Install Frame

1. Go to the non-breakout side of rough opening. Place Header on a flat surface with the removable cover facing up.
2. Refer to the instruction sticker located on each Jamb Tube to properly orientate Jamb Tubes.
3. Remove Cover from Header. Remove Parts boxes and/or Parts bags from inside Header. Set aside.
4. Go to the Roller Track for the Lead Door. Remove (4) Rail Clamps. Set Hardware aside. Remove the Roller Track.
5. Measure to ensure each Jamb Tube is on the correct side of Header. 3/8 inch gap between the Back of Header and the Jamb Tube. 1/4 inch gap between the front of Header and the Jamb Tube.
6. Install Frame to Rough Opening with 1/4 inch diameter anchors or 3/8 inch threaded rods, with a maximum 48 inches on center for the Header and Jamb Tubes (First anchor maximum is 36 inches from each end of the Header).

2 Position the Floor Track

Note: Do Not Secure Floor Track until both the Sidelite and Slide Doors have been installed. Failure to do so may cause misalignment.

1. Obtain Floor Track that was cut to specification at the NABCO Factory.
2. If not installed, obtain Filler Inserts and Threshold Bumpers that were provided by NABCO (cut to specifications).

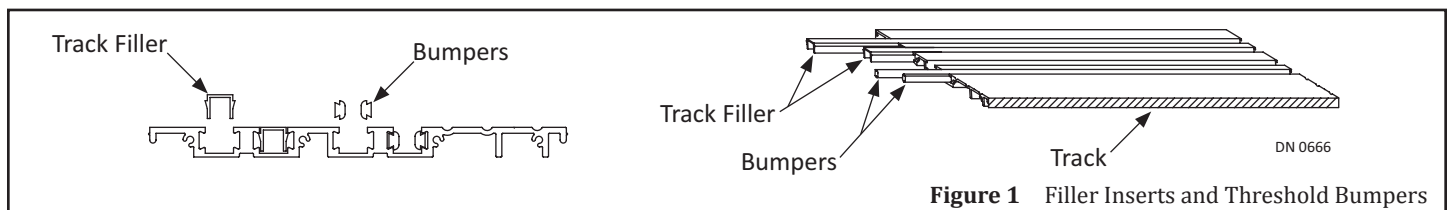

Figure 1 Filler Inserts and Threshold Bumpers

3. Install Filler Inserts within areas that has a door opening. Please see Figure 2.
4. Install Threshold Bumpers within areas that does not have a door opening.

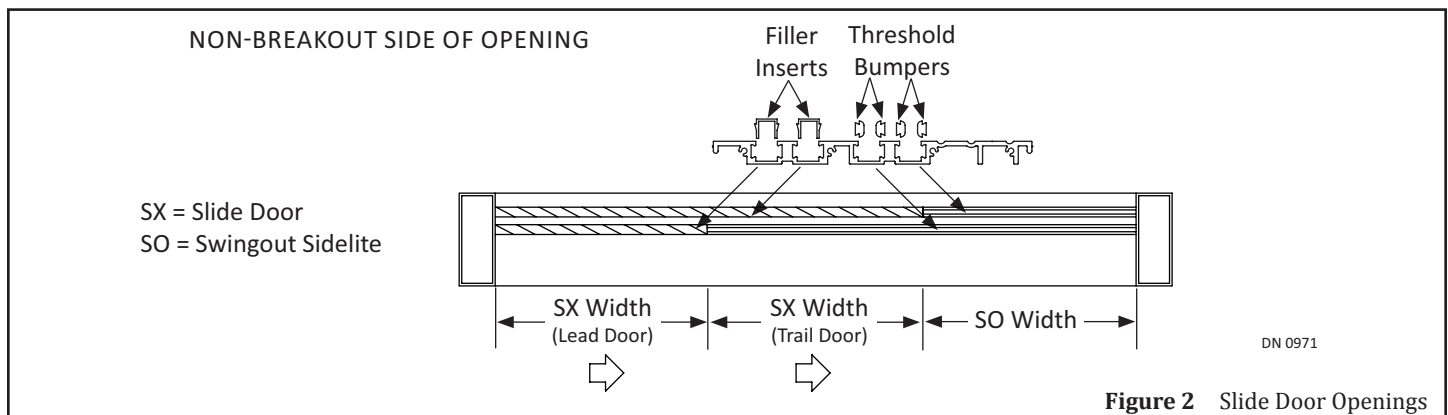

Figure 2 Slide Door Openings

5. On the **Non-Breakout side of opening**, snap a chalk line on the floor from Jamb to Jamb.
6. Position the Floor Track between Jamb tubes until the full length is flush with the chalk line.
 - a. The Floor Track (not including the Ramps) is the same width as the Jamb Tube for both types of Units.

2.1 Recessed Floor Track (Only)

1. Remove the Floor Track. Set aside.
2. Create a channel that is 1/2 inch deep x full width of Jamb Tube x full length of the Floor Track.
 - a. Full length of Floor Track and width of Jamb Tube will vary according to specifications.

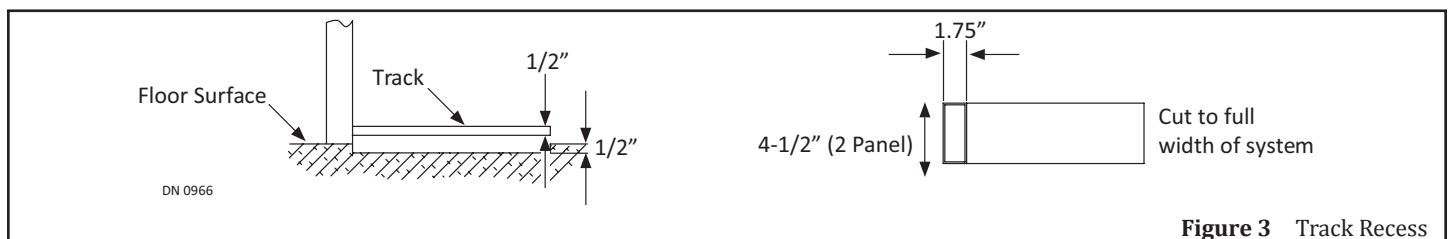
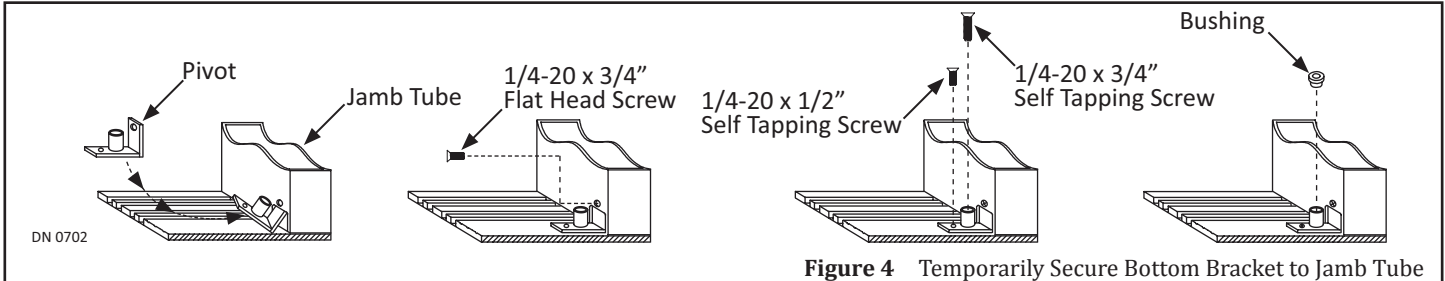

Figure 3 Track Recess

3 Install the Sidelite Panel

1. Obtain the Bottom Pivot assembly provided by NABCO.
2. Insert the Bottom Pivot into a Notch located at the bottom of Jamb tube.
3. Secure Bottom Pivot to Jamb tube with (1) 1/4-20 x 3/4 inch Self Tapping screw.
4. Secure the Bottom Pivot to the Floor with (1) 1/4-20 x 1/2 inch Phillips Screw.
5. Cap the barrel of Pivot with a Bushing provided by NABCO.



6. Obtain (1) Limit Arm Assembly provided by NABCO.
7. Slide (1) Spacer onto the Red Coated 1/4-20 x 1 Flat Head screw. Insert the Red Coated 1/4-20 x 1 Flat Head screw through the Limit Arm screw hole.
8. Slide (1) small Washer and (1 - 2) large Washers (as required) on top of the Red Coated Screw.
9. Secure the Limit Arm to the bottom lip of Header Cover by inserting the Screw assembly into the Factory Drilled Hole.
10. Tighten the Red Coated Screw so the Limit Arm Assembly does not fall out of hole. Do not fully tighten screw at this time.

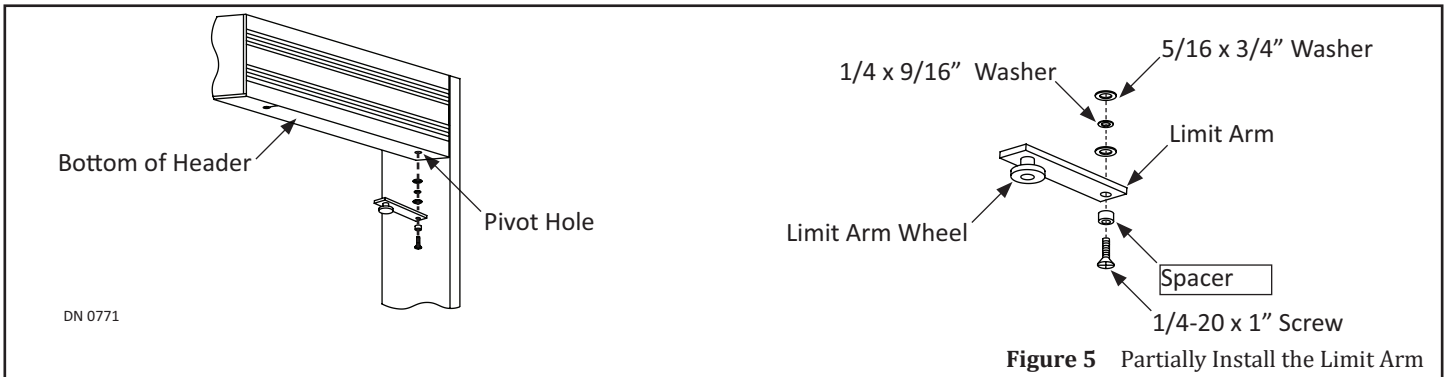

11. Carefully position the Swing Sidelite Panel over the Bottom Pivot. Ensure the Breakout side of the Swing Sidelite Panel is on the breakout side of the opening.

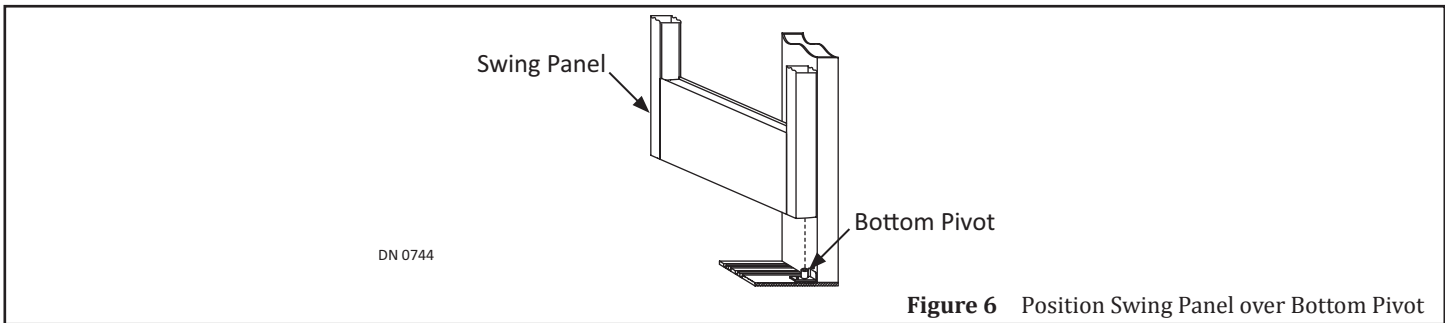

12. Go to the Retracting Pin located inside the Pivot Stile at the very top.
13. Push the Retracting Pin down. At the same time, align the Pivot Pin with the Top Pivot Bracket hole located on bottom of Header. Allow the Pivot Pin to snap into the hole located on the Top Pivot Bracket.
 - a. Ensure Pivot Pin fully engages the hole. If necessary, lift up on the retracting pin with a screwdriver.

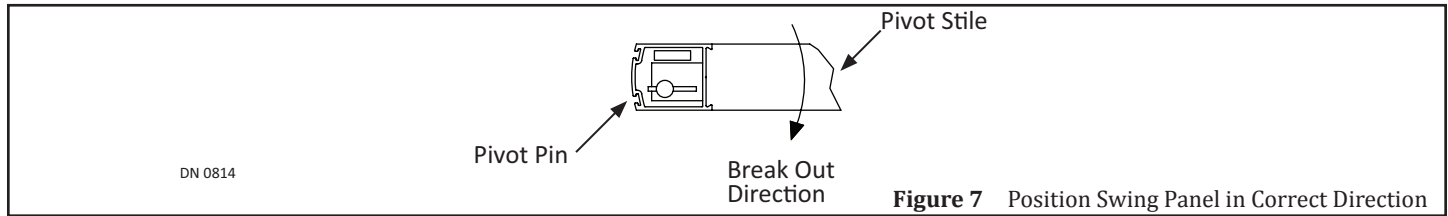

Figure 7 Position Swing Panel in Correct Direction

14. Open the Swing Sidelite Panel out to 90 degrees. Align the Limit Arm with the Top Rail.
15. Rest the Wheel of the Limit Arm inside the Top Rail.
16. Open the Swing Sidelite Panel all the way.
17. Tighten the Red Coated 1/4-20 x 1 Flat Head screw. Do not overtighten.
18. Test the Swing Sidelite Panel to ensure it opens and closes properly. Tighten and/or untighten Red Coated 1/4-20 x 1 Flat Head screw as deemed necessary.

4 Adjust the Ball Detents

Note: Breakout resistance for Ball Detents must meet ANSI Standard A156.10 or Local Codes.

1. With a 15/16" Open End wrench, loosen the Nut to raise or lower the Ball Detent at Top of Strike Stile so it has light contact with the Bottom of Header.
2. Open and close the Swing Door several times to score the surface on the Bottom of Header. Locate and mark where the Score intersects the center groove.
3. With a 1/4 inch diameter drill bit, drill a screw hole through the Bottom of Header. Countersink the screw hole to be 3/8 inch x 82°.

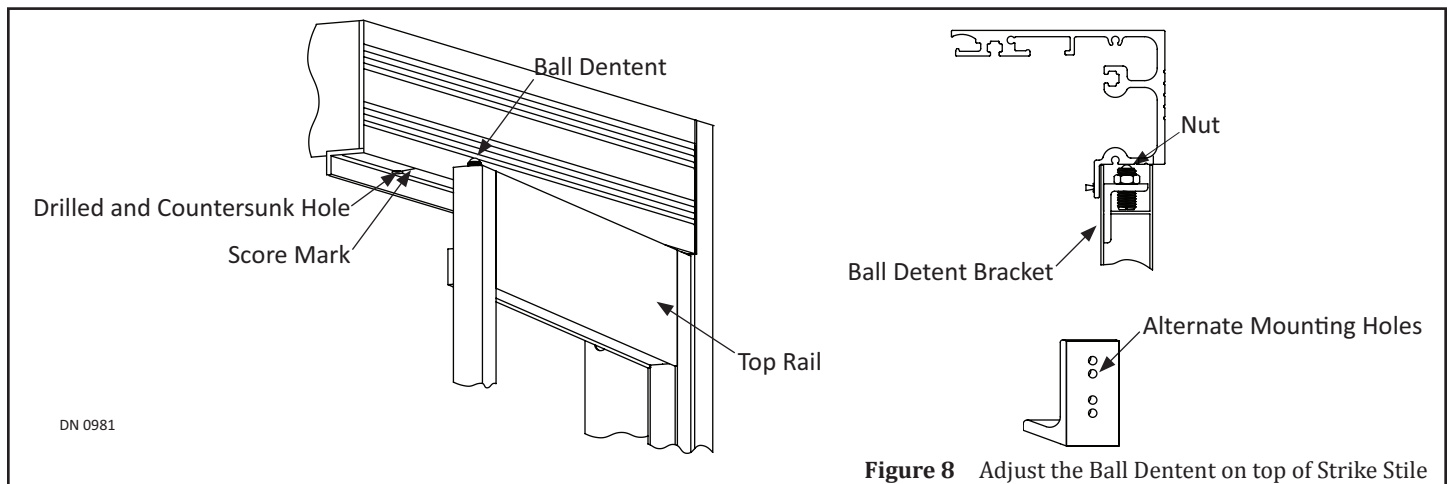

Figure 8 Adjust the Ball Detent on top of Strike Stile

4. With a 15/16" Open End wrench, loosen the Nut to raise or lower the Ball Detent at Bottom of Strike Stile so it has light contact with the Floor Track.
5. Open and close the Swing Door several times to score the surface on the Floor Track.
6. Locate and mark where the Score intersects the center groove.
7. With a 1/4 inch diameter drill bit, drill a hole through the Floor Track (Just deep enough for the Ball Detent to fit within). Countersink the screw hole to be 1/4 inch x 82°.

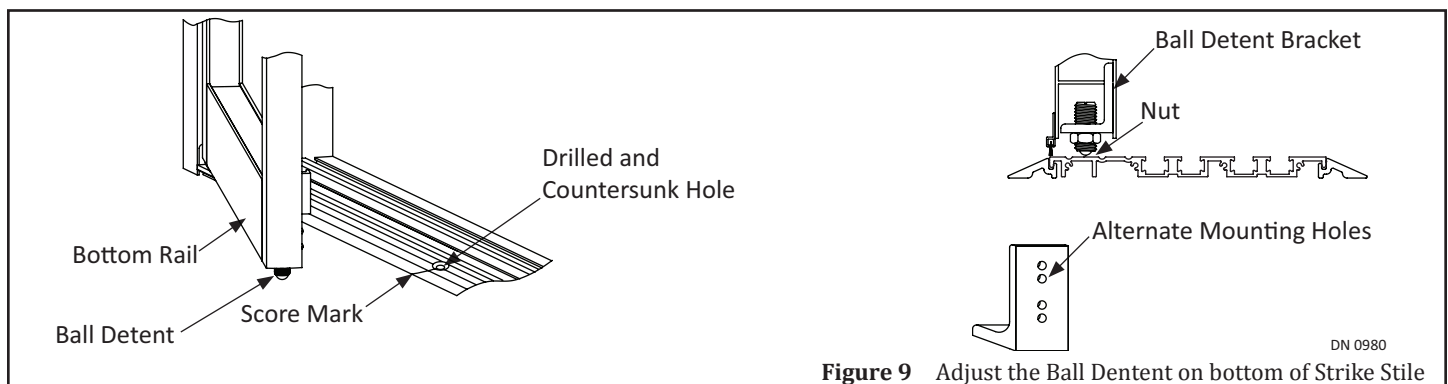
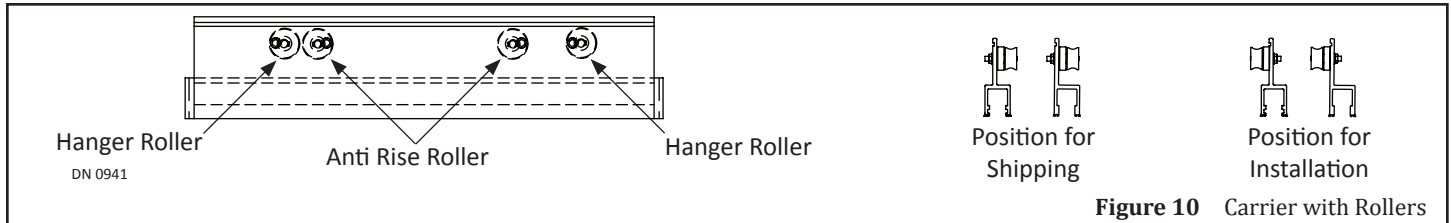

Figure 9 Adjust the Ball Detent on bottom of Strike Stile

8. Close and then break open the Swing door to test fit both Ball Detents.
 - a. Do Not over-drill the hole. If hole is overdrilled the Floor Track will need to be replaced.
 - b. For additional travel remove the ball Detent Bracket to lower or raise the Ball Detent.

5 Install the Trail Door

1. Cover the Sidelite Panel with cardboard on the non-breakout side.
2. Remove each Roller located at the front of Carrier. Refer to the instruction sticker to reinstall each Roller to the back of Carrier. Ensure each Roller is horizontally aligned to each other. Please see Figure 10.



3. Slightly tilt the Slide door to make it easier for the (4) Rollers to 'catch' onto the track.
4. Pry up on the pre-installed Full Open Bottom Guide so the prongs can enter the Floor Track in the appropriate slots.

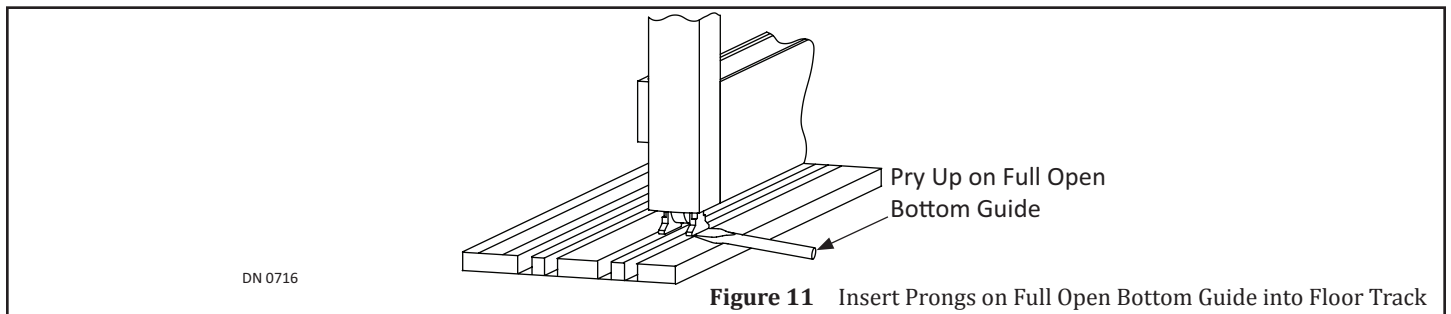

5. Adjust the Trail Door in Section "8 Adjustments"; then come back to complete installation.

6 Install the Lead Door

1. Cover the Trail Door with cardboard on the non-breakout side.
2. Reinstall the Roller Track. It is recommended to tilt the Roller Track until it is inserted within the Header Slot, then dropped down until it is perpendicular to the floor before securing each Rail Clamp.
3. Remove each Roller located at the front of Carrier. Refer to the instruction sticker to reinstall each Roller to the back of Carrier. Ensure each Roller is horizontally aligned to each other.
4. Slightly tilt the Lead door to make it easier for the (4) Rollers to 'catch' onto the track.
5. Pry up on the pre-installed Full Open Bottom Guide so the prongs can enter the Floor Track in the appropriate slots.
6. Adjust the Lead Door in Section "8 Adjustments".

7 Secure the Floor Track

1. Obtain #10 x 1-1/2 inch sheet metal screws and #6 Green Anchors provided by NABCO.
 - a. The number of provided screws and anchors depends upon length of Floor Track.
2. Position as Shown in Figure 12.
3. Go to each end of Floor Track. Mark (1) drill hole approximately 4" from each edge.
4. With a 1/4 inch masonry drill bit, drill through the Floor Track and into the floor no less than 1-1/2 inch deep.
5. Insert plastic anchors into the drilled holes.
6. Secure the Floor Track with #10 x 1-1/2 inch sheet metal screws.

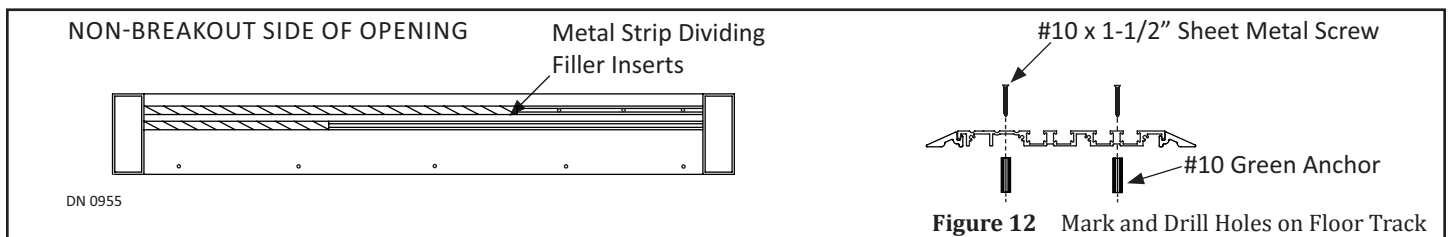

8 Adjustments

8.1 Adjust Height on Trail Door through Mill Cut Out

1. There is a 4-1/2 inch cutout located on the Roller Track directly behind the Hanger Roller. Use a 1/2 inch Wrench and a 5/32 inch Allen Wrench to make adjustments.

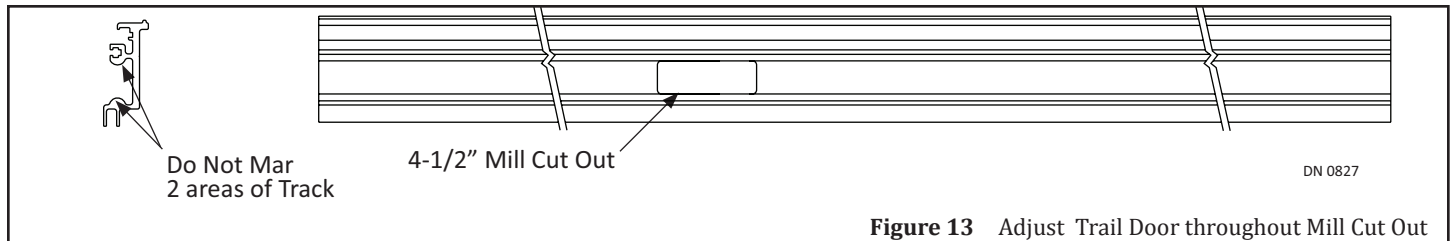

Figure 13 Adjust Trail Door throughout Mill Cut Out

8.2 Adjust Height on Slide Door

CAUTION

Do Not rotate the stud counter-clockwise. Doing so will unthread the Axle from the Hanger Roller assembly.

1. Measure the gap between the door and the floor. The gap must be between 3/16" to 7/16" (3/8" nominal).
2. Loosen each Hanger Roller Nut. It is recommended to adjust the (2) Hanger Rollers located at each end of door first.
3. Turn each axle clockwise to raise or lower the Sliding door. Retighten each Hanger Roller nut. Do not overtighten.
4. Loosen each Anti-Rise Roller nut. Turn each axle clockwise until each Anti-Rise Roller almost makes contact with the top of Roller Track. Gap should be about the same thickness of a credit card. Retighten each Anti-Rise Roller nut. Do not overtighten.

8.3 Adjust Preload on Slide Door

CAUTION

Glass must be installed first before adjusting Preload on Slide Door.

CAUTION

When a Preload Block is shifted, it will be necessary to gently tap on one end of the Interface Leg (located inside the Carrier) until it is properly recentered.

1. Support the weight of sliding door. Breakout sliding door approximately 75 degrees. Check for door sag.
2. Go to the Preload Block located inside the Top Rail. Loosen (2) Locking Bolts.
3. Go to the back edge of Pivot Stile. Reduce door sag by tightening the 5/16 inch Adjustment Set Screw with a 5/32 inch Allen Wrench.
 - a. The door should lift without having to be manually lifted.
 - b. Do not allow the Adjusting Set Screw to protrude more than 5/32 inch past the end of stile.
 - c. If an optional 1/2 inch Adjustment Set Screw provided by NABCO is deemed necessary, it could mean the Preload is misaligned. Go to Section 8.4 before replacing the 5/32 inch Adjustment screw.

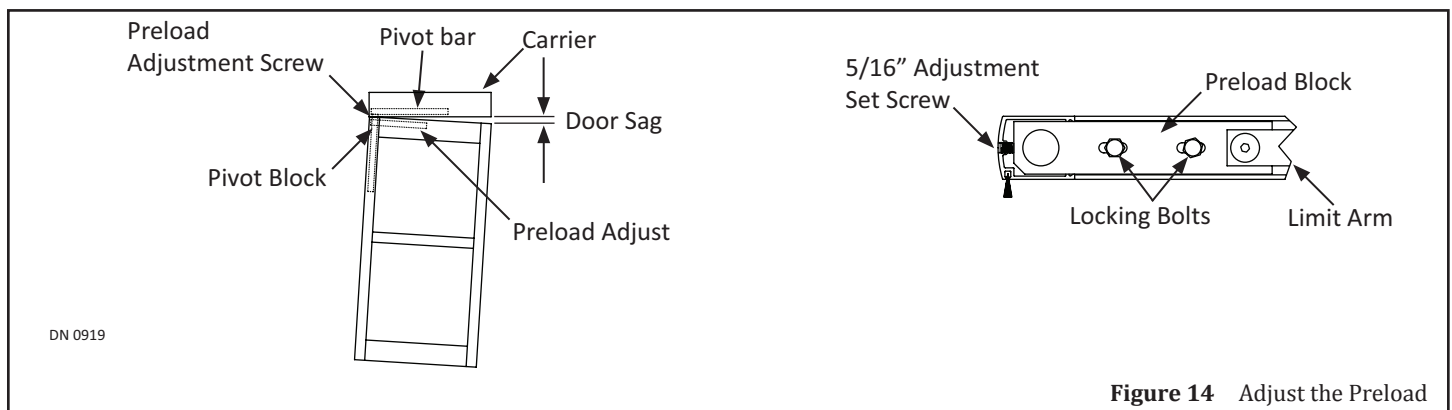
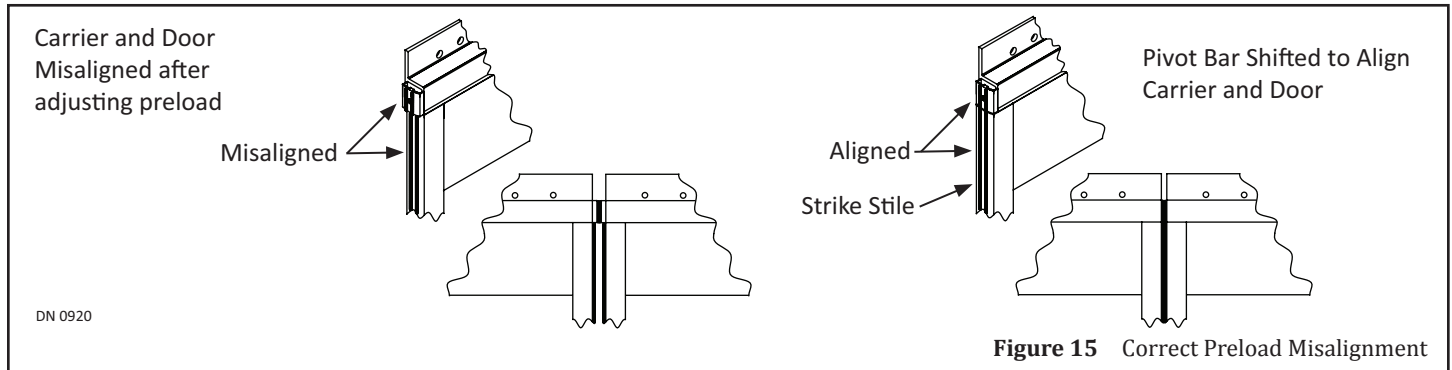

Figure 14 Adjust the Preload

8.4 Correct Preload Misalignment

1. Check to see if misalignment exists on the Strike end of the Door and Carrier.
2. Loosen the Allen head fasteners on the Pivot bar that is located inside the Carrier. Slide the Pivot bar until the door and Carrier are properly aligned.

3. Verify that the Panic Catch inside the Top Rail and the Carrier are still aligned. If not, loosen the 5/16 inch set screw to align the Carrier Panic Catch with the Top Rail Panic Catch.



8.5 Adjust the Nose Caster

Note: Nose Casters are pre-installed for Sliding Doors that are 54 inches Wide (or greater) and/or over 200 pounds.

1. Loosen the #8-32 Set Screw. Position the Wheel so it is perpendicular to the Bottom Rail.
2. Retighten the #8-32 Set Screw.
3. Break open the Slide door. Ensure the Slide door does not scrape the floor. If it does lower the Nose Caster further.

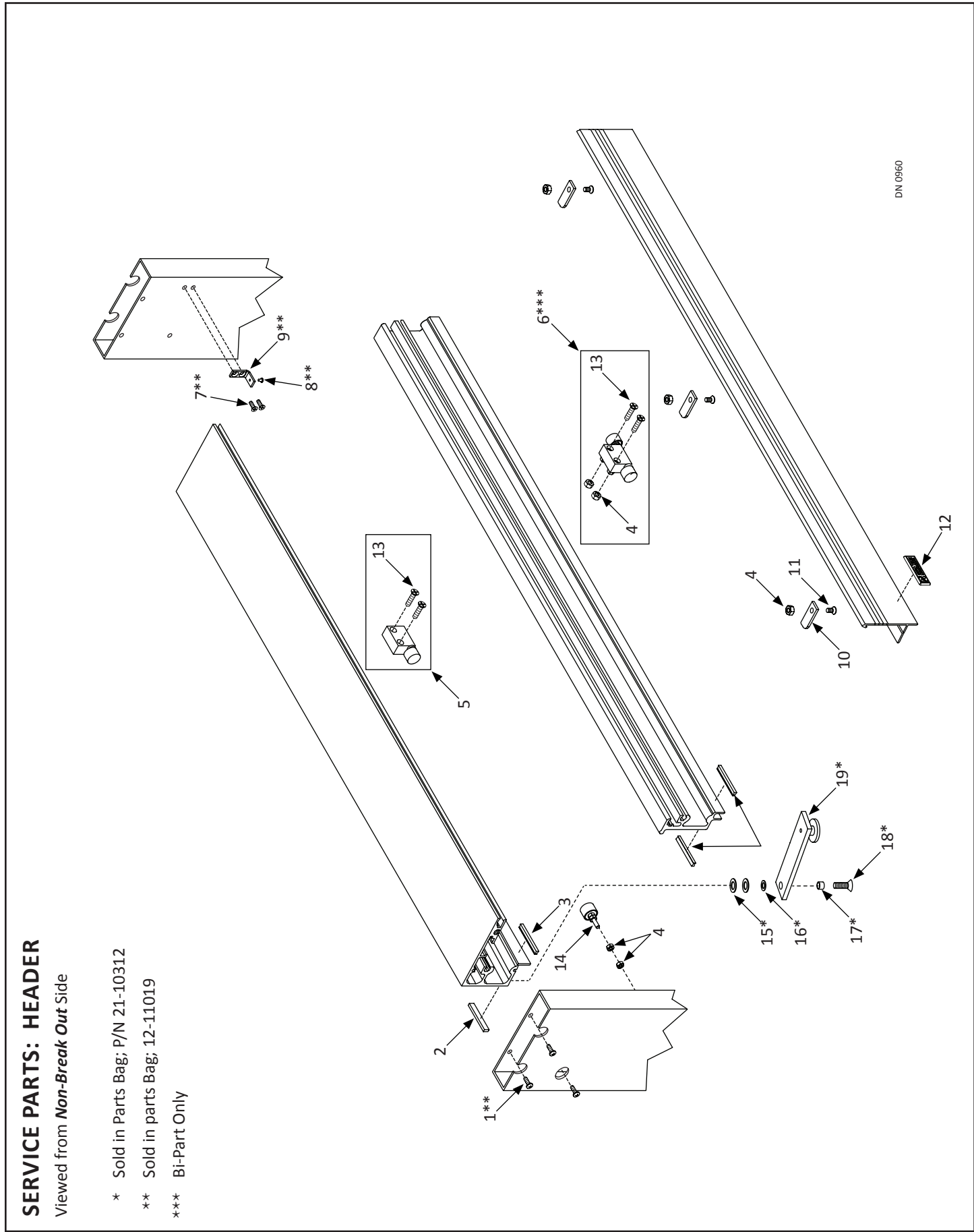

DN 0960

SERVICE PARTS: HEADER
Viewed from *Non-Break Out* Side

- * Sold in Parts Bag; P/N 21-10312
- ** Sold in parts Bag; 12-11019
- *** Bi-Part Only

Header			
Item	Part	Finish/Sizes/Notes	Description
1	24-0015-61	Zinc	RHMS,1/4-20 X 3/4" PHIL, TYPE F, ZN
2	14-8161-01	Smoke Seal only	TAPE, .25 X .50 FOAM
3	14-2279-05	Smoke Seal only/Black	PILE WEATHERING, BLK, .45 TALL, W/ ADHES
4	24-0021-14	Zinc	HEX NUT, 1/4-20, ZN
5	12-10714	Right Hand	END STOP ASSEMBLY - RH
	12-10829	Left Hand	END STOP ASSEMBLY - LH
6	12-11107	Bi-Part	DOOR STOP ASSEMBLY CENTER -BIPART
7	24-0011-70	Zinc	FHMS, 1/4-20 X 7/16", PHIL, UND, ZN
8	24-0015-22	Zinc	RHMS,#8-32 X 1/4", PHIL, ZN
9	14-10727		CLIP, COVER
10	14-10710		RAIL CLAMP, TELESCOPIC
11	24-0011-12	Zinc	FHMS, 1/4-20 X 1/2", PHIL, ZN
12	14-9199		NAMEPLATE, ADHESIVE BACKED
13	24-0011-09		FHMS,1/4-20 X 1,PHILLIPS
14	12-8233		DOOR STOP ASSY JAMB MOUNTD-SPECIAL
15	24-0017-14		WASHER, 5/16 ID X 3/4 OD X .062 THK
16	24-0017-04		WASHER, 1/4 ID X 9/16 OD X .049 THK, STL
17	14-8658		SPACER, LIMIT ARM
18	22-3590-06		SCREW - PHILLIPS FL HD W/VIBR 1/4-20 X 1
19	21-8160		LIMIT ARM ASSY, SWING PANEL

SERVICE PARTS: SIDELITE

Viewed from *Non-Break Out Side*

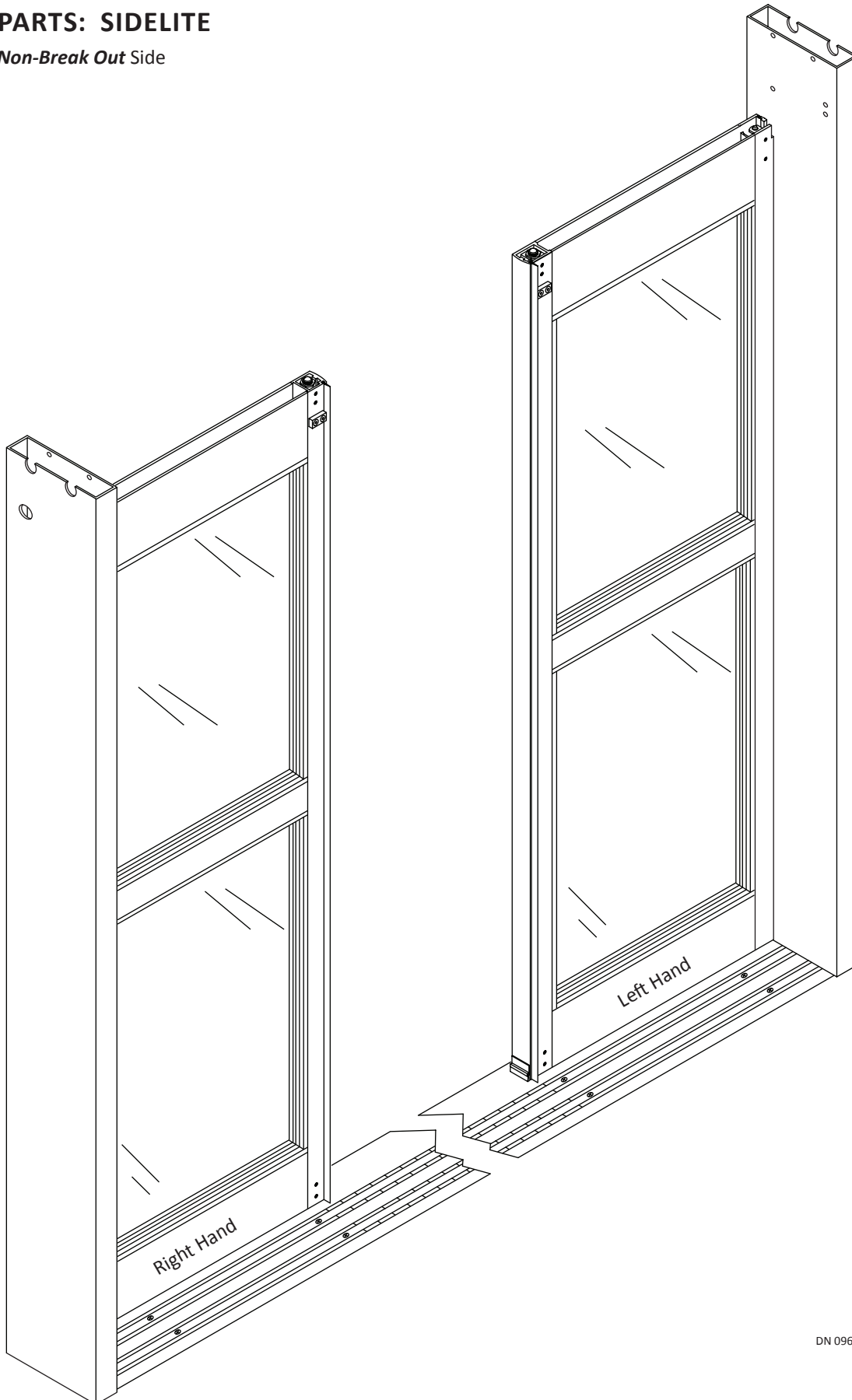

DN 0961

SERVICE PARTS: RIGHT HAND SIDELITE

Viewed from **Non-Break Out** Side

* Sold in Parts Bag; P/N 21-10312

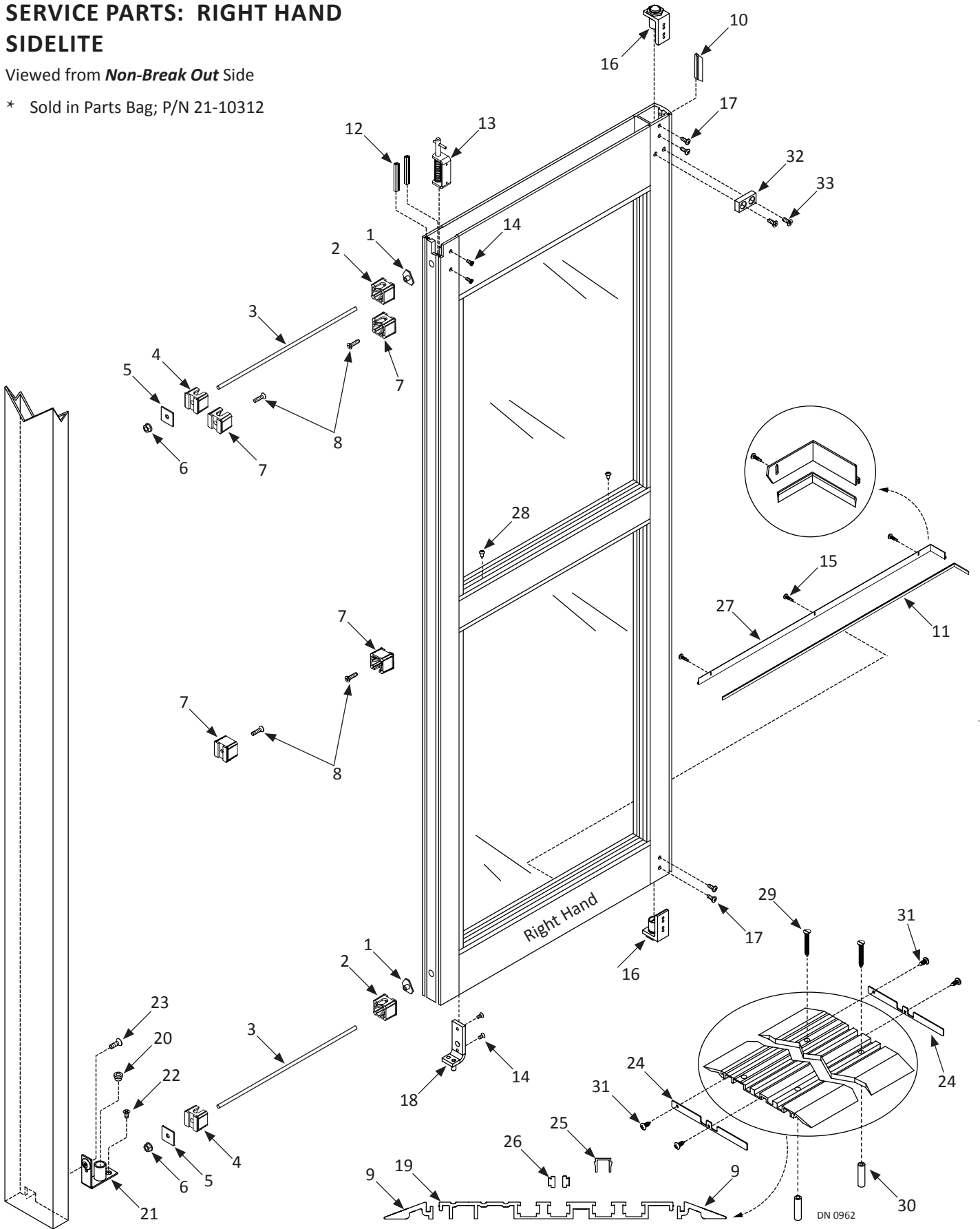

SERVICE PARTS: LEFT HAND SIDELITE

Viewed from **Non-Break Out** Side

* Sold in Parts Bag; P/N 21-10312

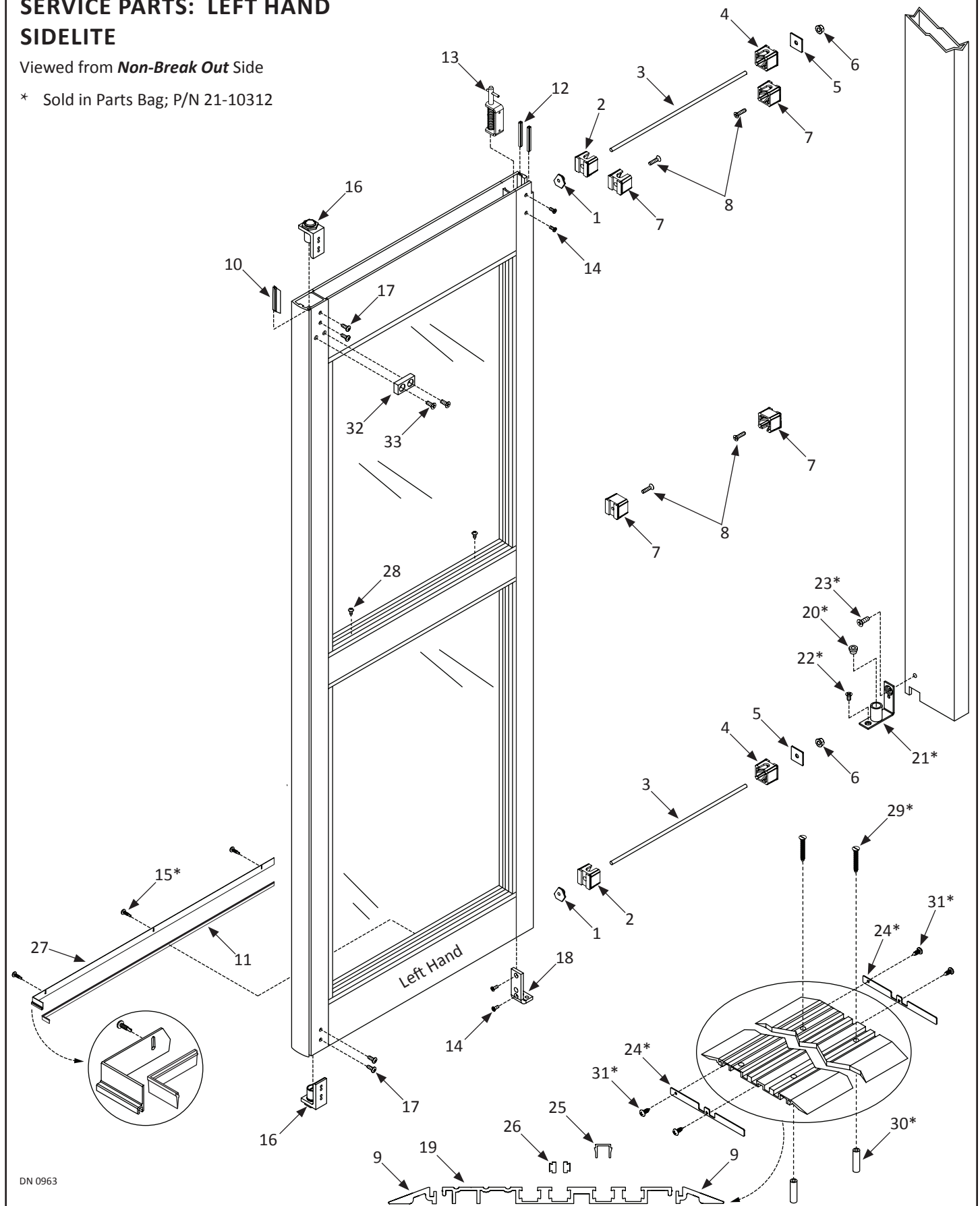

DN 0963

Sidelite			
Item	Part	Finish/Sizes/Notes	Description
1	14-9279		OFFSET TEE NUT, 3/8"-16
2	24-9503		CLIP, MUNTIN BAR - RAIL .500 HOLE
3	14-3624	Zinc	THREADED ROD, 3/8"-16 - ZINC PLATED
4	24-9504		CLIP, MUNTIN BAR - RAIL .386 HOLE
5	14-9225		BACKING PLATE, TIE ROD - DOOR ASSEMBLY
6	24-0021-21	Zinc	NUT, WHIZLOCK, 3/8-16, ZN
7	24-9502		CLIP, MUNTIN BAR - RAIL .261 HOLE
8	24-4941-02	Zinc	FHMS, 1/4-20 X 1", PHIL, TRILOBE, ZN
9	14-9017-01		EXTRUSION, ALUM - RAMP, FLOORTRACK
10	14-5592-01	Smoke Seal Only/Gray	WEATHER STRIP - 9/16 IN VINYL FIN, GRAY
	14-5592-02	Smoke Seal Only/Black	WEATHER STRIP - 9/16 IN VINYL FIN, BLACK
11	14-3933-01	Smoke Seal Only/Gray	WEATHERING GRAY VINYL 1 IN FIN
	14-3933-02	Smoke Seal Only/Black	WEATHERING BLACK VINYL 1 IN FIN
12	14-8632	Black	WEATHERING TRI POLY BLACK BULB
13	21-9507		ASM, TOP PIVOT, 1175 SWING PANEL
14	24-0011-105		FHMS, 10-32 X 1/2", PHIL, UND, ZN
15	24-0013-03	Smoke Seal Only/Zinc	PHSMS, 6 X 1/2", PHIL, TEKS, ZN
	24-0013-04	Smoke Seal Only/Black Zinc	PHSMS, 6 X 1/2", PHIL, TEKS, BLK ZN
16	12-9082		BALL DETENT PANIC, SWING PANEL
17	24-0012-14		PHMS, #10-32 X .50 LG, PHL, ZINC
18	11-9509-01	LH	BOTTOM PIVOT SWING PANEL ASSY - LH
	11-9509-02	RH	BOTTOM PIVOT SWING PANEL ASSY - RH
19	24-10049-01		EXTRUSION,ALUM-FLOOR TRACK,TELE-204
20	24-2458		BOTTOM PIVOT BUSHING, SWING PANEL
21	22-4750		FLOOR PIVOT SUB-ASSY - GT1100 & 1175
22	24-4941-01		FHMS, 1/4-20 X 1/2", TYP F, UND, PHL, ZN
23	24-0011-13		FHMS, 1/4-20 X 3/4", PHIL, ZN
24	24-9857-20		END CAP, THRESHOLD - FOR POCKETED UNITS
25	14-9168		EXTRUSION, RPVC - FILLER, TRACK
26	14-9019		BUMPER, THRESHOLD
27	14-10659-01	Smoke Seal Only/LH/Clear	WEATHERING HOLDER
	14-10659-02	Smoke Seal Only/LH/Dark Bronze	WEATHERING HOLDER
	14-10660-01	Smoke Seal Only/RH/Clear	WEATHERING HOLDER
	14-10660-02	Smoke Seal Only/RH/Dark Bronze	WEATHERING HOLDER
28	24-0031-23		FHSMS, 10 X 3/4", TYPE A, PHIL, ZN
29	24-0031-17		FHSMS, 8 X 1 1/2", TYPE A, PHIL
30	14-6394		ANCHOR, STRT PLSTC 10-12" X 1"
31	24-0094-12		PHSMS, 6 X 3/8", TYPE AB, PHIL
32	14-10766		SPACER 2100 TELESCOPIC
33	24-0011-131		FHMS, 10-32X1/2", PHIL, TYP 23, UND, ZN

SERVICE PARTS: TRAIL DOOR

Viewed from *Non-Break Out* Side

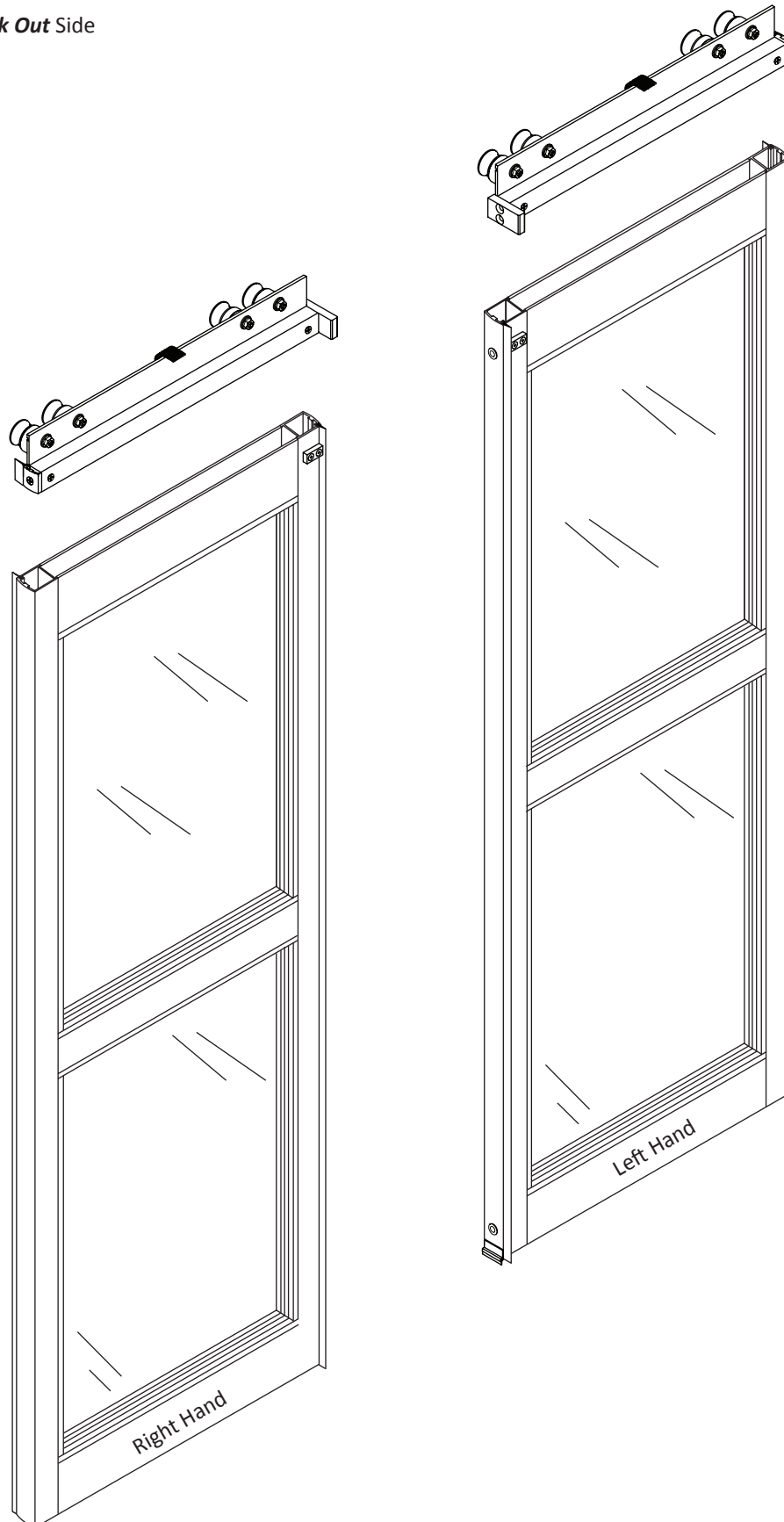

DN 0964

SERVICE PARTS: RIGHT HAND TRAIL DOOR

Viewed from *Non-Break Out* Side

Sold in Parts Bag; P/N 12-11019

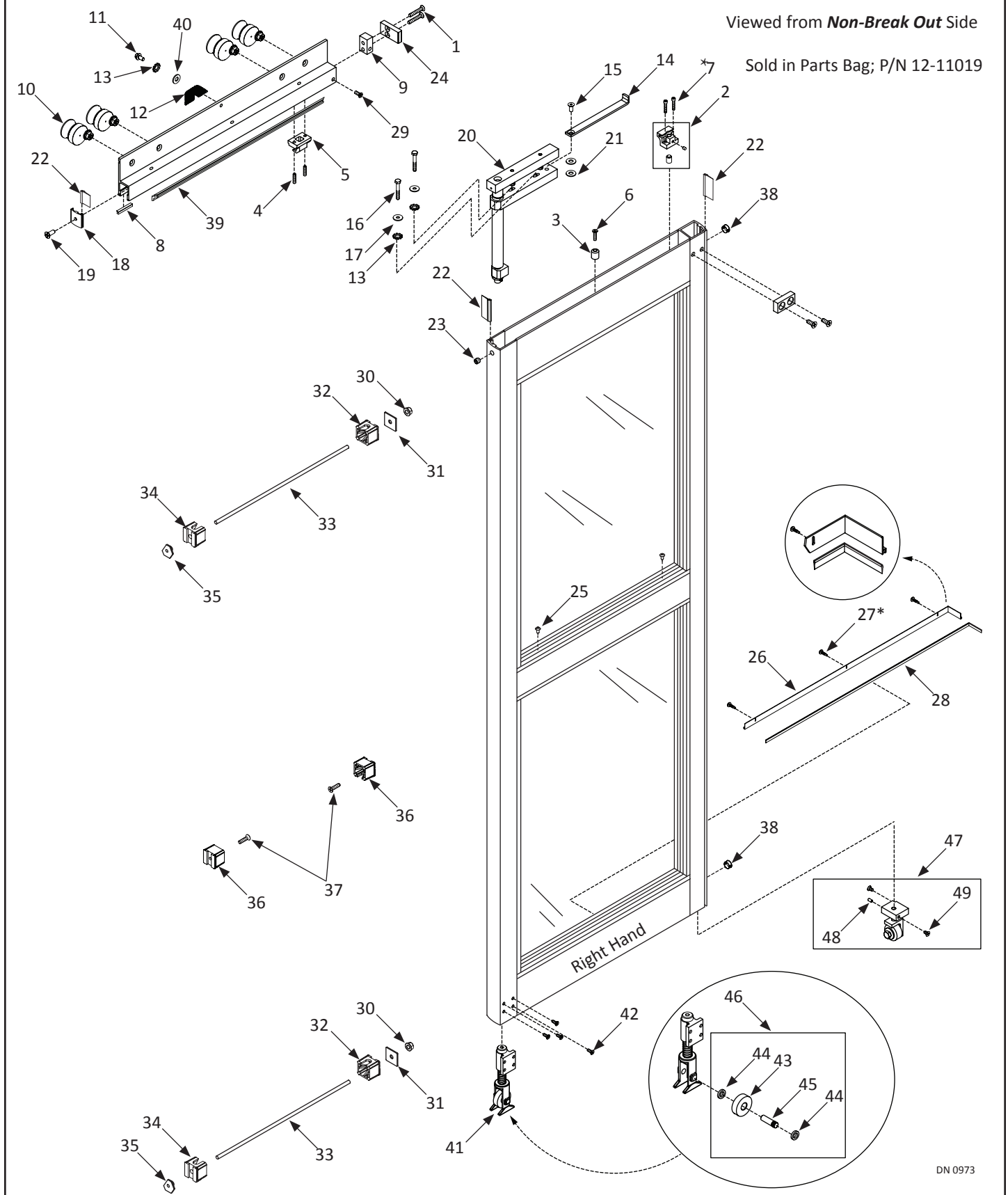

DN 0973

SERVICE PARTS: LEFT HAND TRAIL DOOR

Viewed from *Non-Break Out* Side

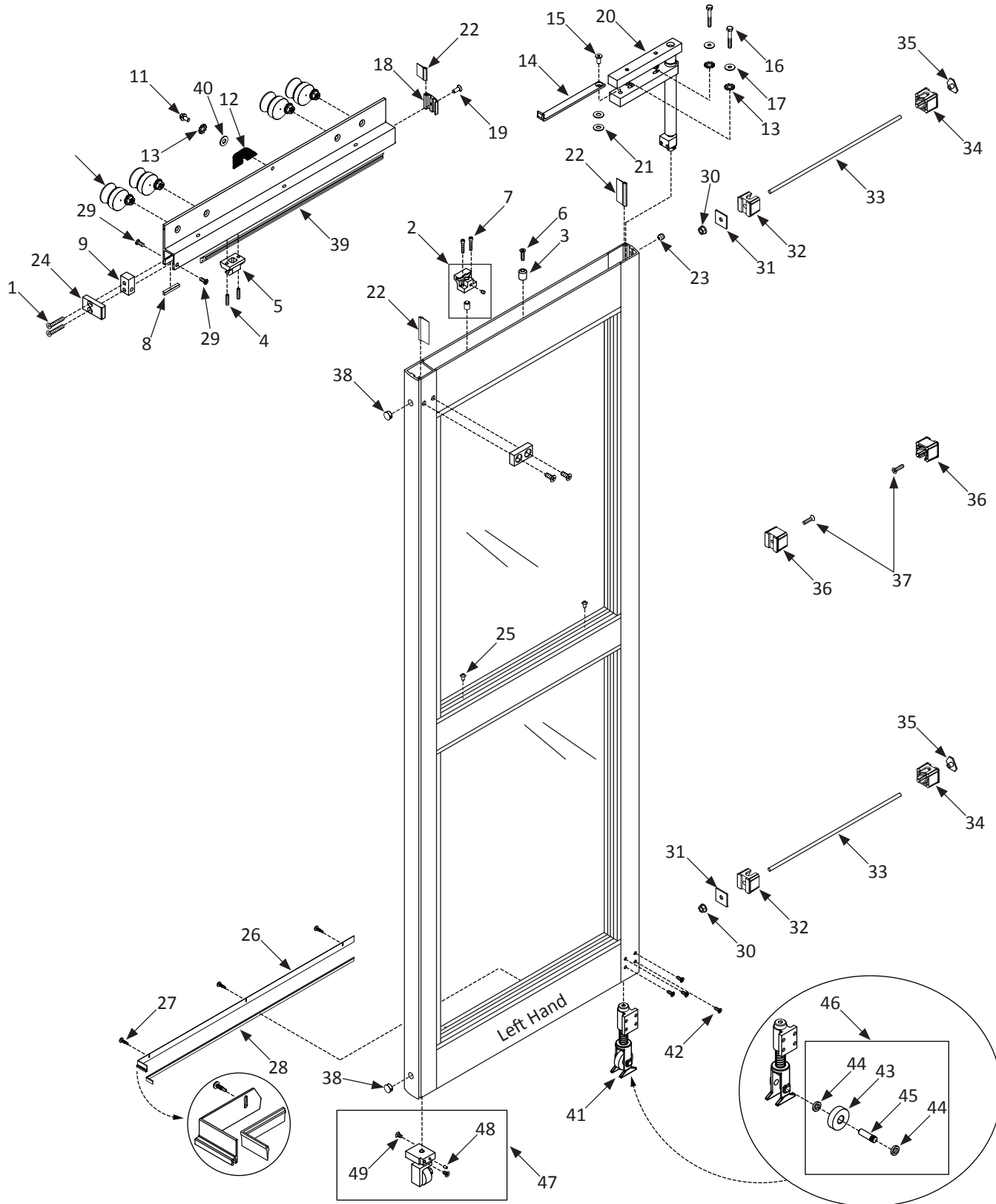

DN 0972

Trail Door			
Item	Part	Finish/Sizes/Notes	Description
1	24-0011-71		FHCS, 1/4-20 X 1 1/4", BLK OX, GRADE 8
2	21-3468		ASM, PANIC CATCH, LOWER PART
3	14-8447		LIMIT ARM SUPPORT
4	24-0016-30		SHSS, 5/16-18 X 1.25", CUP
5	24-9483		PANIC CATCH, UPPER PART
6	24-4941-02	Zinc	FHMS, 1/4-20 X 1", PHIL, TRILOBE, ZN
7	24-0010-16		SHCS, 1/4-20 X 1 1/4"
8	14-2279-04	Smoke Seal Only	PILE WEATHERING, BLK, .20 TALL, CARRIER
9	14-12065		STRIKE MOUNTING BLOCK - COME ALONG
10	12-10027		30mm HANGER ROLLER & HUB SUBASSY
11	24-0014-39	Green	HWHMS, 1/4-20 X 3/8", SLOT, GREEN
12	14-10907-01		STATIC ARRESTOR STRIP 4"
13	24-0019-05		1/4" EXTERNAL STAR WASHER
14	21-8396		LIMIT ARM, STD STILES
15	24-0011-77	Zinc	FHCS, 7/16-14 X 1", ZN
16	24-0014-12		HHCS, 1/4-20 X 1 3/4"
17	24-0017-04		WASHER, 1/4 ID X 9/16 OD X .049 THK, STL
18	14-10561-01	Clear	END CAP, PIVOT - TRAIL DOOR MILLED 204
	14-10561-02	Dark Bronze	END CAP, PIVOT - TRAIL DOOR 313
19	24-0011-130	Black Zinc	FHMS 10-32X1/2" PHIL TYP 23, UND, BLK ZN
	24-0011-131	Zinc	FHMS, 10-32X1/2", PHIL, TYP 23, UND, ZN
20	24-12002-10		CARRIER PVT ASSY NARROW STILE-UL PART
	24-12002-20		CARRIER PVT ASSY MED STILE-UL PART
	24-12002-30		CARRIER.PVT ASY - NRW STL-PNL <22.75-UL
	24-12002-40		CARRIER.PVT ASY - MD STL- PNL < 22.75"UL
21	24-0017-02		WASHER, 7/16 ID X 1 OD X .083 THK
22	14-5592-01	Smoke Seal Only/Gray	WEATHER STRIP - 9/16 IN VINYL FIN, GRAY
	14-5592-02	Smoke Seal Only/Black	WEATHER STRIP - 9/16 IN VINYL FIN, BLACK
23	24-0016-51	Black Oxide	SHSS, 5/16-24 X 5/16" CUP PT, BLK OX
24	14-12066-01	Clear	STRIKE BRACKET - COME ALONG BRACKET 204
	14-12066-02	Dark Bronze	STRIKE BRACKET - COME ALONG BRACKET 313
25	24-0094-01		PHSMS, 10 X 1/2", PHIL, TYPE A
26	14-10659-01	Smoke Seal Only/LH/Clear	WEATHERING HOLDER
	14-10659-02	Smoke Seal Only/LH/Dark Bronze	WEATHERING HOLDER
	14-10660-01	Smoke Seal Only/RH/Clear	WEATHERING HOLDER
	14-10660-02	Smoke Seal Only/RH/Dark Bronze	WEATHERING HOLDER
27	24-0013-03	Smoke Seal Only/Zinc	PHSMS, 6 X 1/2", PHIL, TEKS, ZN
	24-0013-04	Smoke Seal Only/Black Zinc	PHSMS, 6 X 1/2", PHIL, TEKS, BLK ZN
28	14-3933-01	Smoke Seal Only/Gray	WEATHERING GRAY VINYL 1 IN FIN
	14-3933-02	Smoke Seal Only/Black	WEATHERING BLACK VINYL 1 IN FIN
29	24-0011-105		FHMS, 10-32 X 1/2", PHIL, UND, ZN
30	24-0021-21	Zinc	NUT, WHIZLOCK, 3/8-16, ZN

Trail Door			
Item	Part	Finish/Sizes/Notes	Description
31	14-9225		BACKING PLATE, TIE ROD - DOOR ASSEMBLY
32	24-9504		CLIP, MUNTIN BAR - RAIL .386 HOLE
33	14-3624	Zinc	THREADED ROD, 3/8"-16 - ZINC PLATED
34	24-9503		CLIP, MUNTIN BAR - RAIL .500 HOLE
35	14-9279		OFFSET TEE NUT, 3/8"-16
36	24-9502		CLIP, MUNTIN BAR - RAIL .261 HOLE
37	24-4941-02	Zinc	FHMS, 1/4-20 X 1", PHIL, TRILOBE, ZN
38	14-9511-04		PLUG, HOLE, .813 DIAMETER, BLK
39	24-9094-01	Clear	INTERFACE LEG - 204
	24-9094-02	Dark Bronze	INTERFACE LEG - 313
40	24-0017-46		WASHER, FLAT 1/4X5/8X.051/.080
41	21-9053-01		BTM GUIDE ASSY - CAST NRW STILE-UL PART
42	24-0011-53		FHMS,10-32 X 1/2 ,PHIL,UL PART
43	14-9045-01		BTM ROLLER DOOR URETHANE-ULPART
	14-9045-02		BTM RLR DOOR URETH MED STILE-UL PART
44	24-0667-01		SPACER, MOUNTING - END CAP-UL PART
45	14-7061		SHAFT, ROLLER-UL PART
46	14-11320-10		KIT, ASSY, REPAIR, GT1175, NARROW STILES
	14-11320-20		KIT, ASSY, REPAIR, GT1175, MEDIUM STILES
47	14-5543-11	Clear	NOSE CASTER ASSY NARROW STILE
	14-5543-12	Dark Bronze	NOSE CASTER ASSY
	14-5543-21	Clear	NOSE CASTER ASSY MED. STILE
	14-5543-22	Dark Bronze	NOSE CASTER ASSY
48	24-0016-05		SHSS, 8-32 X 5/16, CUP PT
49	24-0011-70		FHMS, 1/4-20 X 7/16", PHIL, UND, ZN
	24-0011-73		FHMS,1/4-20 X 7/16", PHIL, UND, BLK OX
50	14-10766		SPACER 2100 TELESCOPIC
51	24-0011-131		FHMS, 10-32X1/2", PHIL, TYP 23, UND, ZN

SERVICE PARTS: LEAD DOOR

Viewed from *Non-Break Out* Side

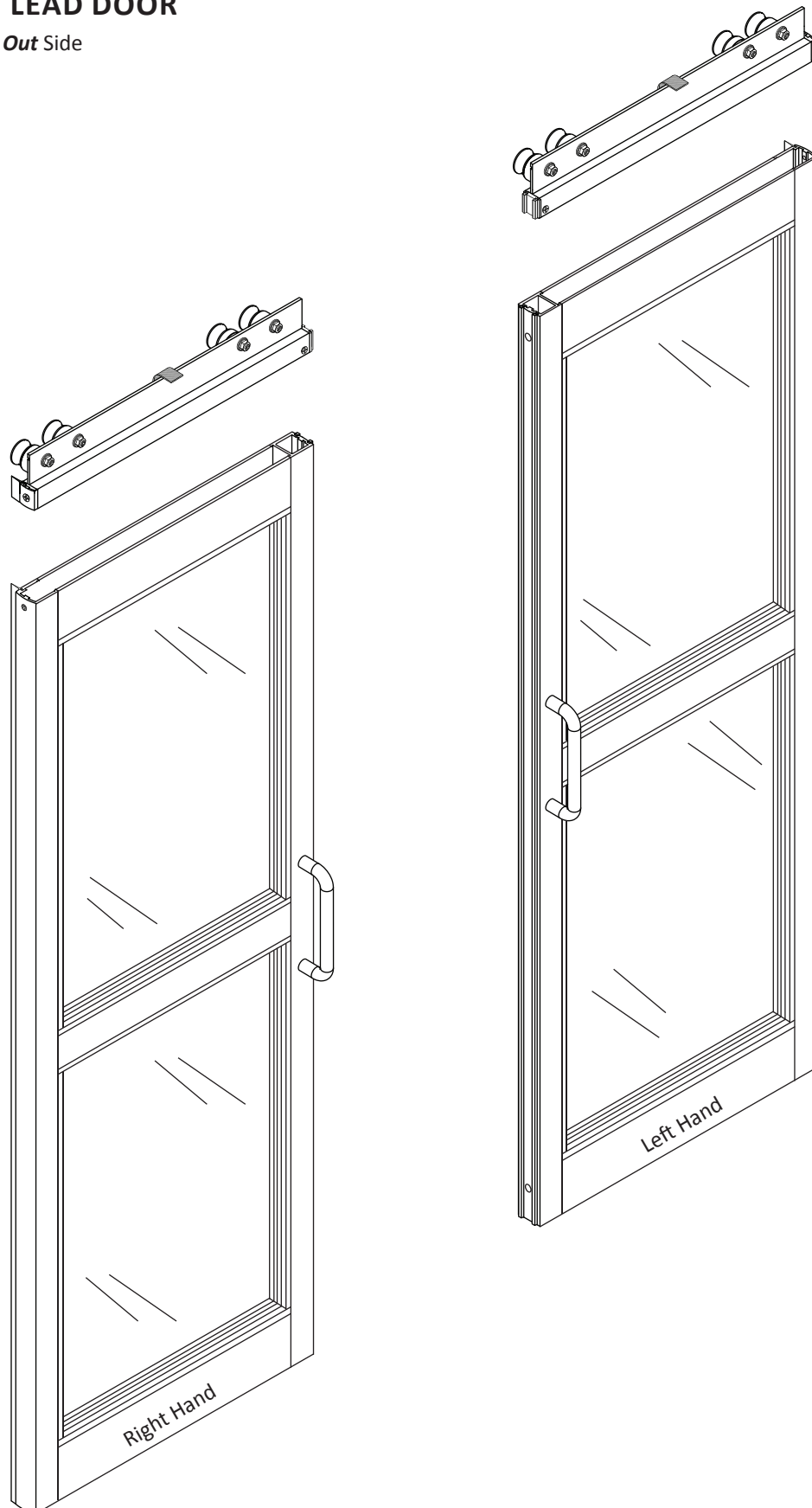

DN 0924

SERVICE PARTS: RIGHT HAND LEAD DOOR

Viewed from *Non-Break Out* Side

* Sold in Parts Bag; P/N 12-11019

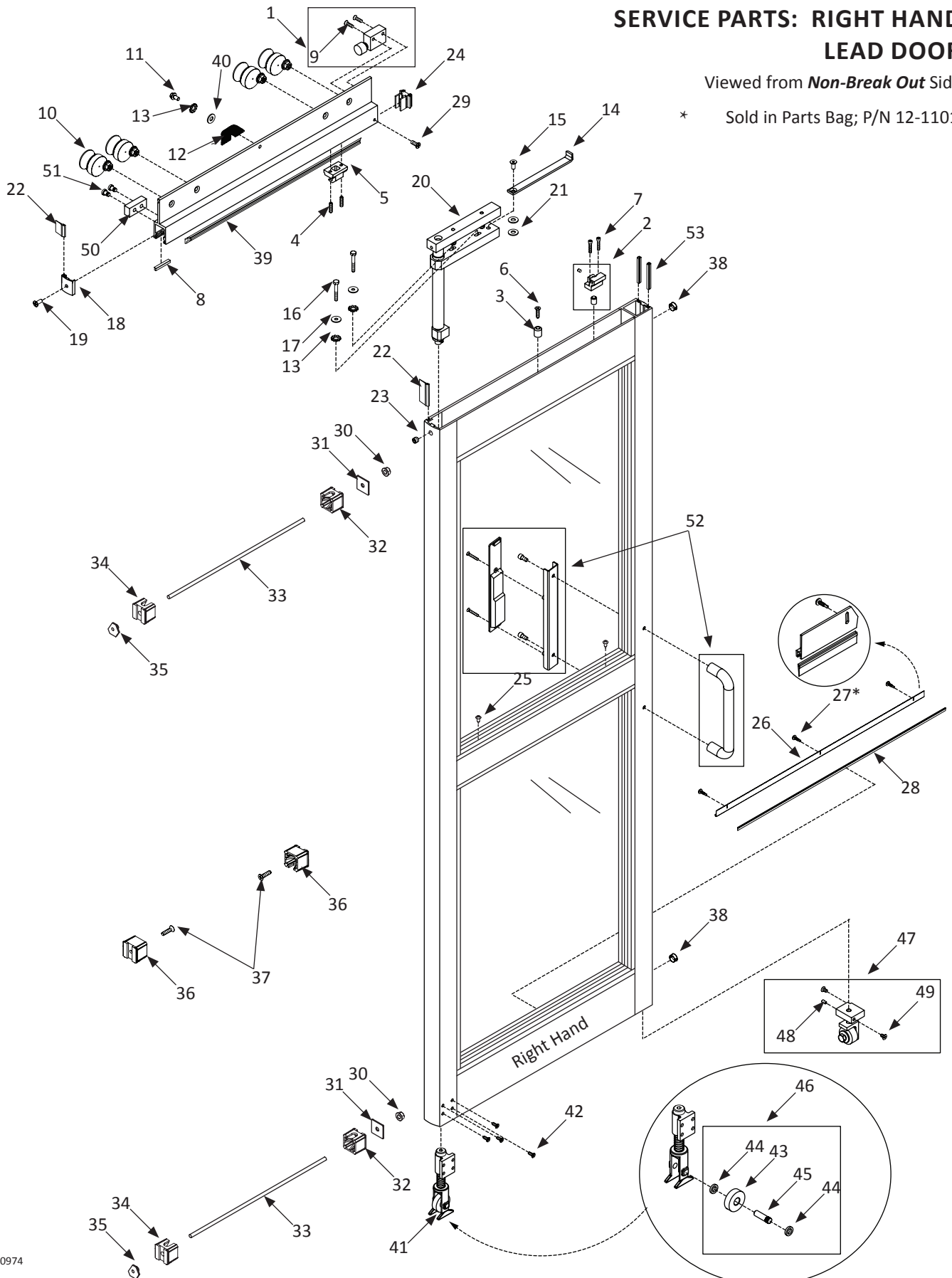

DN 0974

SERVICE PARTS: LEFT HAND LEAD DOOR

Viewed from *Non-Break Out* Side
* Sold in Parts Bag; P/N 12-11019

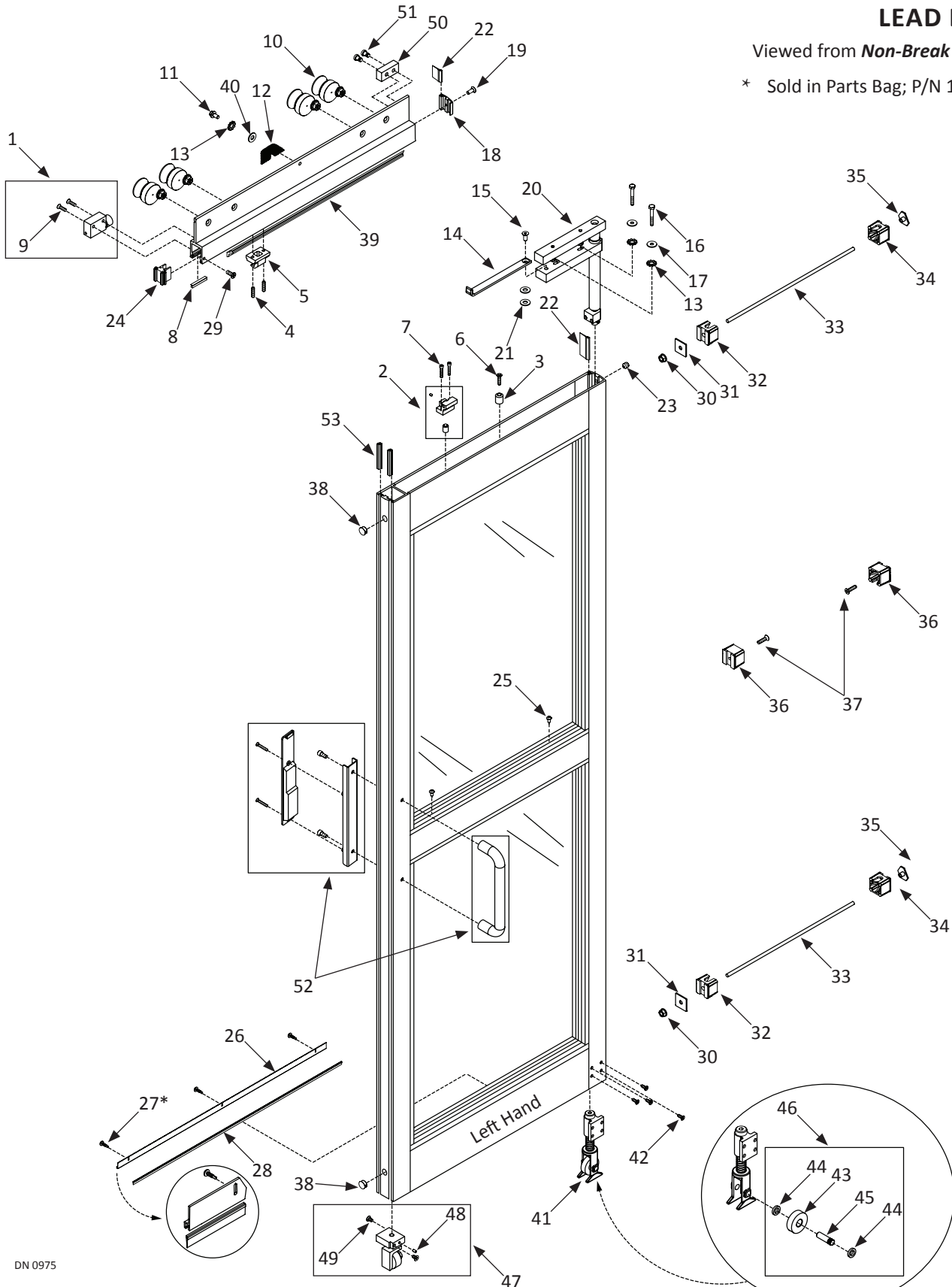

DN 0975

Lead Door			
Item	Part	Finish/Sizes/Notes	Description
1	12-12070-01	Clear	COME ALONG ASSEMBLY RH 204
	12-12070-02	Dark Bronze	COME ALONG ASSEMBLY RH 313
	12-12071-01	Clear	COME ALONG ASSEMBLY LH 204
	12-12071-02	Dark Bronze	COME ALONG ASSEMBLY LH 313
2	21-3468		ASM, PANIC CATCH, LOWER PART
3	14-8447		LIMIT ARM SUPPORT
4	24-0016-30		SHSS, 5/16-18 X 1.25", CUP
5	24-9483		PANIC CATCH, UPPER PART
6	24-4941-02	Zinc	FHMS, 1/4-20 X 1", PHIL, TRILOBE, ZN
7	24-0010-16		SHCS, 1/4-20 X 1 1/4"
8	14-2279-04	Smoke Seal Only	PILE WEATHERING, BLK, .20 TALL, CARRIER
9	24-0011-107	Zinc	FHMS, 1/4-20 X 7/8", PHIL, ZN
	24-0011-134	Black Zinc	FHMS, 1/4-20 X 7/8", PHIL, BLK ZN
10	12-10027		30mm HANGER ROLLER & HUB SUBASSY
11	24-0014-39	Green	HWHMS, 1/4-20 X 3/8", SLOT, GREEN
12	14-10907-01		STATIC ARRESTOR STRIP 4"
13	24-0019-05		1/4" EXTERNAL STAR WASHER
14	21-8396		LIMIT ARM, STD STILES
15	24-0011-77	Zinc	FHCS, 7/16-14 X 1", ZN
16	24-0014-12		HHCS, 1/4-20 X 1 3/4"
17	24-0017-04		WASHER, 1/4 ID X 9/16 OD X .049 THK, STL
18	14-10561-01	Clear	END CAP, PIVOT - TRAIL DOOR MILLED 204
	14-10561-02	Dark Bronze	END CAP, PIVOT - TRAIL DOOR 313
19	24-0011-130	Black Zinc	FHMS 10-32X1/2" PHIL TYP 23, UND, BLK ZN
	24-0011-131	Zinc	FHMS, 10-32X1/2", PHIL, TYP 23, UND, ZN
20	24-12002-10		CARRIER PVT ASSY NARROW STILE-UL PART
	24-12002-20		CARRIER PVT ASSY MED STILE-UL PART
	24-12002-30		CARRIER.PVT ASY - NRW STL-PNL <22.75-UL
	24-12002-40		CARRIER.PVT ASY - MD STL- PNL < 22.75" UL
21	24-0017-02		WASHER, 7/16 ID X 1 OD X .083 THK
22	14-5592-01	Smoke Seal Only/Gray	WEATHER STRIP - 9/16 IN VINYL FIN, GRAY
	14-5592-02	Smoke Seal Only/Black	WEATHER STRIP - 9/16 IN VINYL FIN, BLACK
23	24-0016-51	Black Oxide	SHSS, 5/16-24 X 5/16" CUP PT, BLK OX
24	12-10882-01		CAP, END STRIKE SIDE ASSY. BULB
	12-10882-02		CAP, END CARRIER STRIKE SIDE ASSB 313
25	24-0094-01		PHSMS, 10 X 1/2", PHIL, TYPE A
26	24-9125-01	Smoke Seal Only/LH/Clear	WEATHERING EXT, 204
	24-9125-02	Smoke Seal Only/LH/Dark Bronze	WEATHERING EXT, 313
27	24-0013-03	Smoke Seal Only/Zinc	PHSMS, 6 X 1/2", PHIL, TEKS, ZN
	24-0013-04	Smoke Seal Only/Black Zinc	PHSMS, 6 X 1/2", PHIL, TEKS, BLK ZN
28	14-3933-01	Smoke Seal Only//Gray	WEATHERING GRAY VINYL 1 IN FIN
	14-3933-02	Smoke Seal Only//Black	WEATHERING BLACK VINYL 1 IN FIN

Lead Door			
Item	Part	Finish/Sizes/Notes	Description
29	24-0011-105		FHMS, 10-32 X 1/2", PHIL, UND, ZN
30	24-0021-21	Zinc	NUT, WHIZLOCK, 3/8-16, ZN
31	14-9225		BACKING PLATE, TIE ROD - DOOR ASSEMBLY
32	24-9504		CLIP, MUNTIN BAR - RAIL .386 HOLE
33	14-3624	Zinc	THREADED ROD, 3/8"-16 - ZINC PLATED
34	24-9503		CLIP, MUNTIN BAR - RAIL .500 HOLE
35	14-9279		OFFSET TEE NUT, 3/8"-16
36	24-9502		CLIP, MUNTIN BAR - RAIL .261 HOLE
37	24-4941-02	Zinc	FHMS, 1/4-20 X 1", PHIL, TRILOBE, ZN
38	14-9511-04		PLUG, HOLE, .813 DIAMETER, BLK
39	24-9094-01	Clear	INTERFACE LEG - 204
	24-9094-02	Dark Bronze	INTERFACE LEG - 313
40	24-0017-46		WASHER, FLAT 1/4X5/8X.051/.080
41	21-9053-01		BTM GUIDE ASSY - CAST NRW STILE-UL PART
42	24-0011-53		FHMS,10-32 X 1/2 ,PHIL,UL PART
43	14-9045-01		BTM ROLLER DOOR URETHANE-ULPART
	14-9045-02		BTM RLR DOOR URETH MED STILE-UL PART
44	24-0667-01		SPACER, MOUNTING - END CAP-UL PART
45	14-7061		SHAFT, ROLLER-UL PART
46	14-11320-10		KIT, ASSY, REPAIR, GT1175, NARROW STILES
	14-11320-20		KIT, ASSY, REPAIR, GT1175, MEDIUM STILES
47	14-5543-11	Clear	NOSE CASTER ASSY NARROW STILE
	14-5543-12	Dark Bronze	NOSE CASTER ASSY
	14-5543-21	Clear	NOSE CASTER ASSY MED. STILE
	14-5543-22	Dark Bronze	NOSE CASTER ASSY
48	24-0016-05		SHSS, 8-32 X 5/16, CUP PT
49	24-0011-70		FHMS, 1/4-20 X 7/16", PHIL, UND, ZN
	24-0011-73		FHMS,1/4-20 X 7/16", PHIL, UND, BLK OX
50	14-12068		BUMPER - COME ALONG BRACKET
51	24-0010-50		SHCS, 1/4-20 X 3/8", ZN, LOW
52	12-12958-01	Clear	KIT, ICU D/RECESSED HANDLE
	12-12958-02	Dark Bronze	KIT, ICU D/RECESSED HANDLE
53	14-8632		WEATHERING TRI POLY BLACK BULB