



GT 710/8710 Swing Doors Low Energy Quick Set-Up and Parts Guide

P/N 15-12499-003 Rev 12-19-14

Nabco Entrances Inc. S82 W18717 Gemini Drive Muskego, Wisconsin 53150
Phone: (877) 622-2694 Fax: (888) 679-3319 www.nabcoentrances.com

Associated Manuals Part Numbers: Low Energy Swing Door Systems 710/8710 P/N 15-10683
Magnum IV Control Wiring and Adjustment Manual ;P/N 15-10682
NABCO Price Book P/N 16-9244-30 (for Sensors, Switches, and Accessories)

WARNING

- Turn OFF all power to the Automatic Door if a Safety System is not working.
- Instruct the Owner to keep all power turned OFF until corrective action can be achieved by a NABCO trained technician. Failure to follow these practices may result in serious consequences.
- NEVER leave a Door operating without all Safety detection systems operational.

Table of Contents

SECTION 1: INSTALL THE HEADER	2
SECTION 2: 110 VAC GENERAL WIRING	5
SECTION 3: INSTALL THE FIRST HALF OF SWING ARM	6
SECTION 4: INSTALL THE SECOND HALF OF SWING ARM	11
SECTION 5: INSTALL THE MAGNETS	14
SECTION 6: INSTALL THE ARM STOP	16
SECTION 7: MAGNUM GENERAL WIRING	17
SECTION 8: ADJUSTMENTS	19
SERVICE PARTS: GT 710 LOW ENERGY HEADER	22
SERVICE PARTS: GT 8710 LOW ENERGY HEADER	24
SERVICE PARTS: LOW ENERGY SWING ARM ASSEMBLIES	26

SECTION 1: INSTALL THE HEADER

1.1 Inswing Doors

**FOR OUTSWING UNITS SKIP TO
SUBSECTION 1.2**

1. Open the Swing door 90 degrees.
2. Measure between the wall and the outside face of the Swing Door.
 - a. There must be a 2 inch minimum gap.
 - b. If there is less than a 2 inch gap, please call Customer Service at (877) 622-2694.

1.2 Prepare the Header

Note: It may be necessary to remove the Motor/Operator from the Header to reduce weight, while positioning the Header onto the Door Frame.

1. Place Header on flat surface with Side facing up. Protect header from scratches.
2. Remove two screws from underneath cover. Set Aside.
3. Remove Cover by:
 - ▶ GT710: Lifting it straight off of Header.
 - ▶ GT8710: Lifting it up from Header, and then pulling it out.
4. Remove boxes and/or parts bags from inside Header. Set aside.

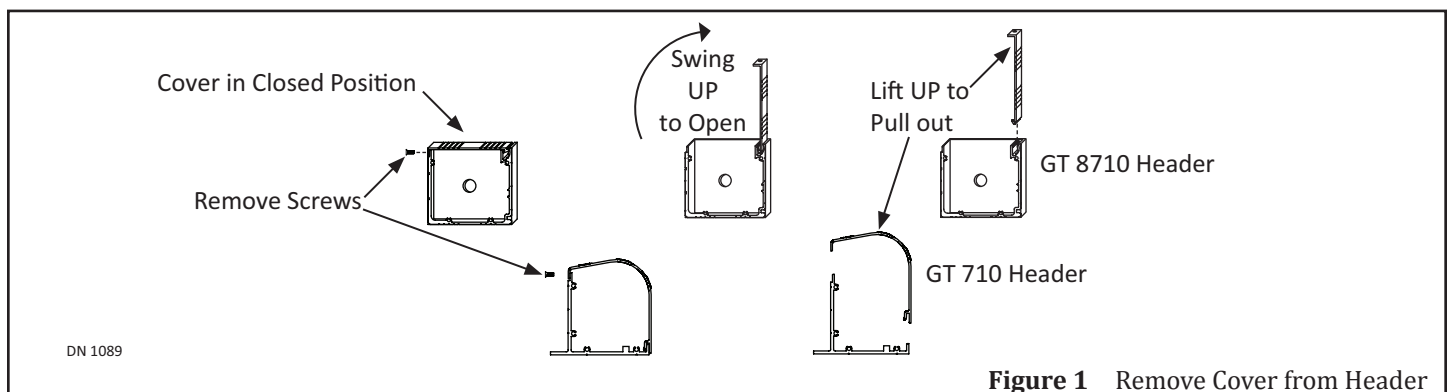

Figure 1 Remove Cover from Header

1.1.1 Drill Holes in Header (GT 8710)

**FOR GT710 UNITS SKIP TO
SUBSECTION 1.3**

1. Go to the Strike side of Header. Drill one 7/8 inch hole through the Header to allow all wiring to be drawn inside.
 - a. The GT-8710 Header can be ordered with a Knockout hole located at either end of the Header. For details, please call Customer Service at 1-888-679-3319.
2. Go to the back wall inside Header on the Pivot side.
3. Measure 1 inch from the End Cap of Header towards the center. Mark a Vertical Line.
4. Measure at least 1/2 inch from the bottom of Header towards the top. Mark a Horizontal Line across the Vertical line. This is the center of the first screw hole. Drill 1/4 inch screw hole.
5. Mark (1) more Horizontal line across the Vertical line directly above the first screw hole. This is the center of the second screw hole. Drill 1/4 inch screw hole.
 - a. It may be necessary to install a Shim behind the Header if mounting the Header to a wall.
6. Go to the Strike side of Header. Repeat steps 3 thru 5.

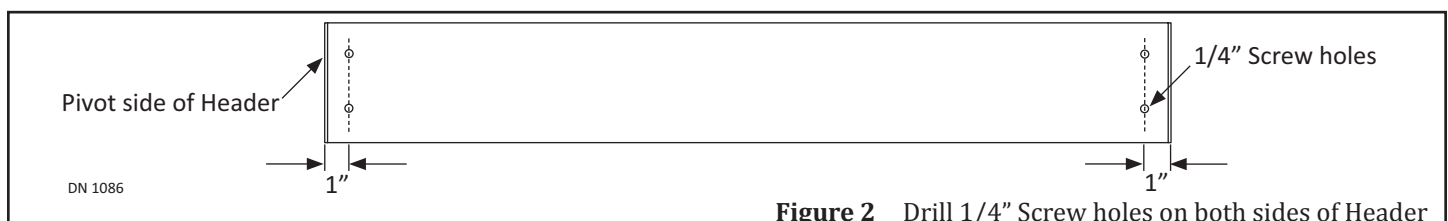

Figure 2 Drill 1/4" Screw holes on both sides of Header

1.3 Prepare the Door Frame

Note: The following instructions are for typical Metal Doors and Frame Profile. It is recommended to use lag bolts.

Note: If the Door Frame is not properly reinforced nor anchored to the building surface, and/or is hollow, reinforce the Door Frame with 1/4-20 blind rivnuts (not provided by NABCO).

Note: If the Door Frame is not Metal, ensure the Door Frame being used is of equal strength.

1. Go to the Pivot Side of Swing door.
2. Measure up from the Bottom edge of the Top door frame:
 - ▶ GT 710: 1/8 inch
 - ▶ GT 8710: 1-1/8 inch
3. Mark a Horizontal Line on the face of Top door frame, at both ends.

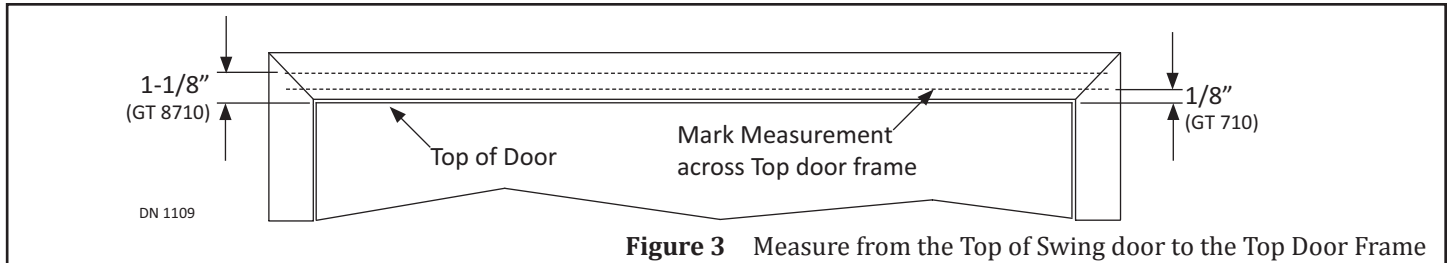

Figure 3 Measure from the Top of Swing door to the Top Door Frame

4. Lift the Header up against the Top door frame until the bottom edge of Header is butted up against the Horizontal Line, at both ends.
5. To ensure proper operation of the Swing Arm:
 - ▶ For a Door Jamb that is 1-3/4 inches wide, position the Pivot side of Header so it is flush to the outside edge of the Pivot Door Jamb.
 - ▶ For a Door Jamb that is wider than 1-3/4 inches, measure from the inner edge of the Pivot Door Jamb to the center. Mark a vertical line at the 1-3/4 inch measurement. The Pivot side of Header must butt against the 1-3/4 inch mark.

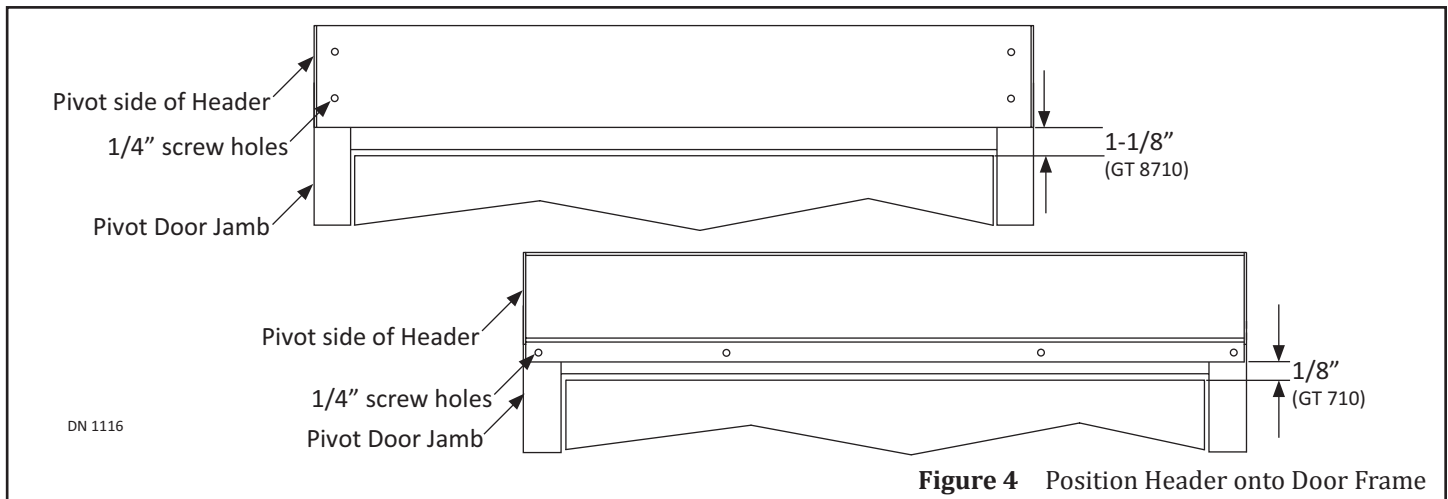

Figure 4 Position Header onto Door Frame

6. Ensure the Header is square and level.
7. Use the Header as a template to mark screw holes onto the face of the door frame.
8. Remove the Header. Set Aside.

1.4 Install the Shim (Only if deemed necessary)

**FOR UNITS NOT INSTALLING A SHIM SKIP TO
SUBSECTION 1.5**

1. Butt the Header up against the Horizontal line, line up the screw holes and then ensure the Header is square and level.
2. Go to the top of Header. Mark a horizontal line along the top edge of Header onto the wall.
3. Measure the depth between the back side of the Header and the wall.
 - a. Write that measurement down and label it #1.

4. Measure the distance between the top of door frame and the horizontal line that was just drawn at the top of Header.
 - a. Write that measurement down and label it #2.

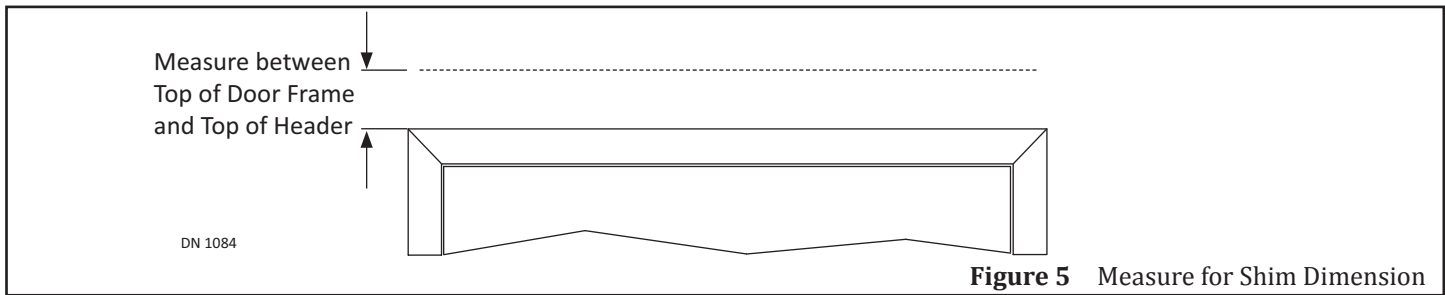

5. Obtain (1) Shim to be the same depth as measurement #1; no higher than measurement #2; and about the same width as the Header.
6. Secure the Shim to stud(s).
 - a. It is recommended to use Lag Bolts.

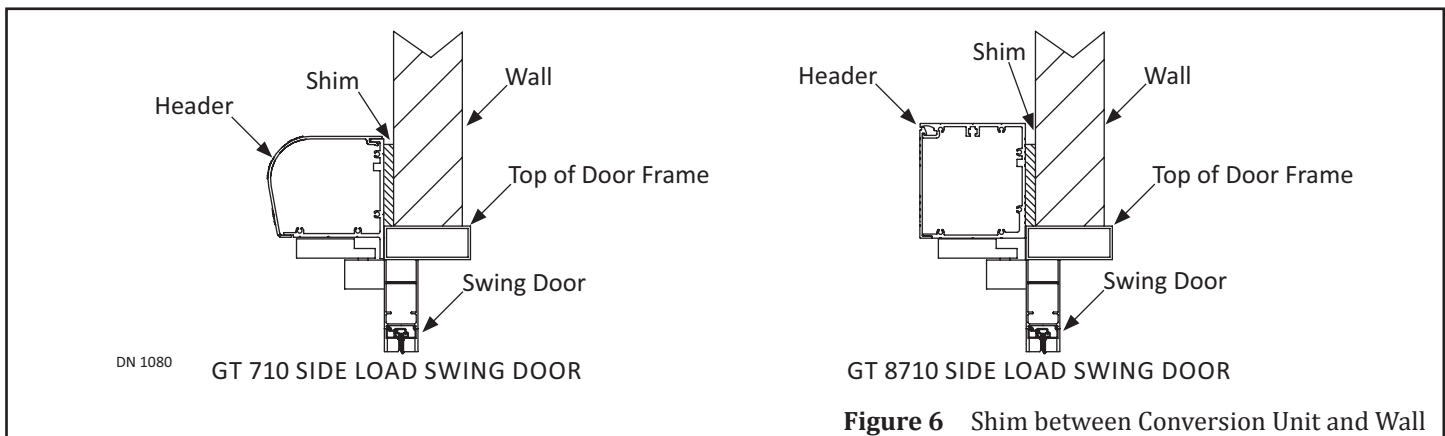

1.5 Secure the Header to the Door Frame

1. Lift up the Header to insert Power Wiring through the 7/8 inch hole.
 - a. It is recommended to use a Conduit.
 - b. It is recommended to insert all other Wiring through a separate hole.
2. Line up the screw holes. Secure the Header to the Door Frame. It is recommended to use Lag Bolts.
 - a. For additional mounting on GT 8710 units: secure the Header to Studs located behind the Shim. It is recommended to use Lag Bolts.

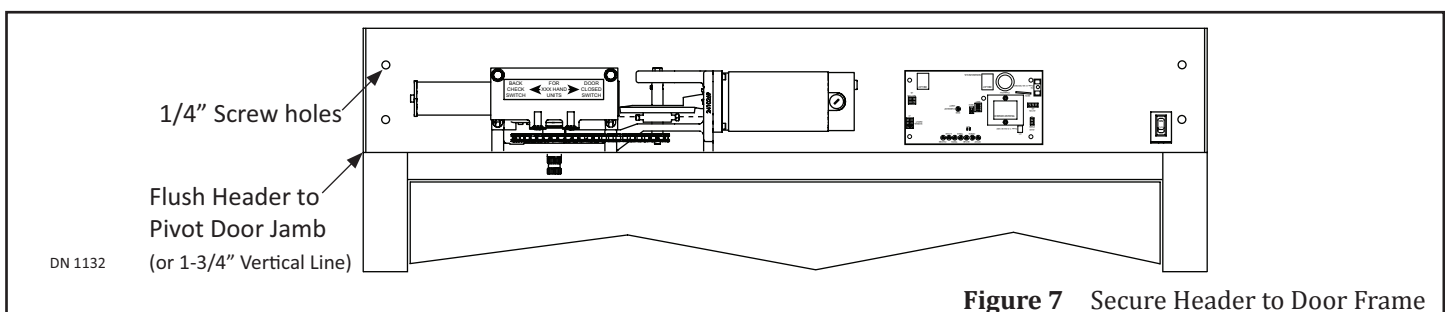

SECTION 2: 110 VAC GENERAL WIRING

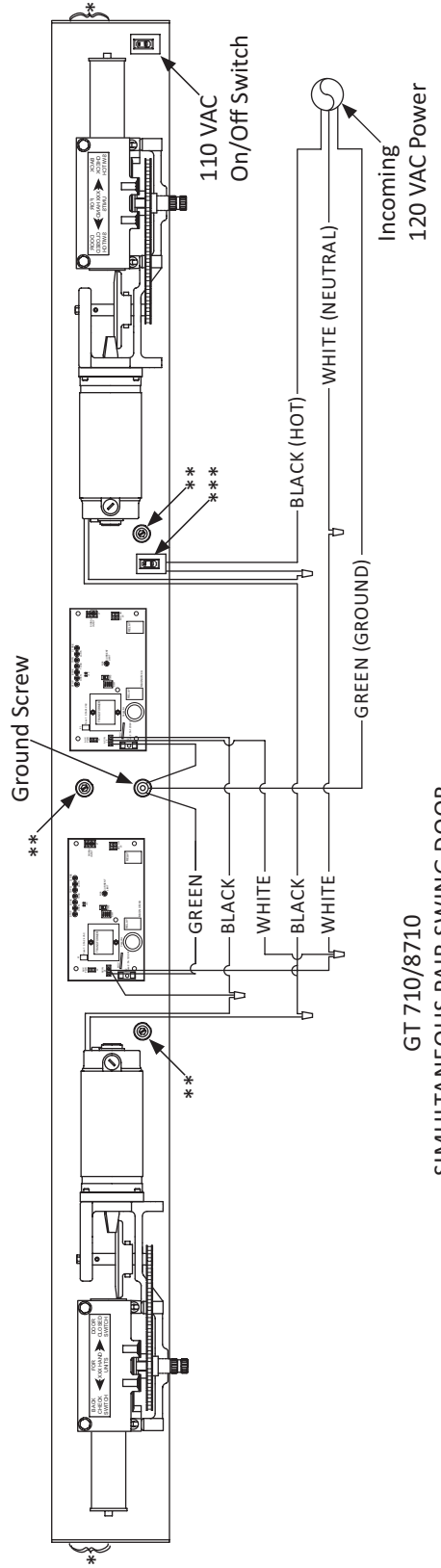
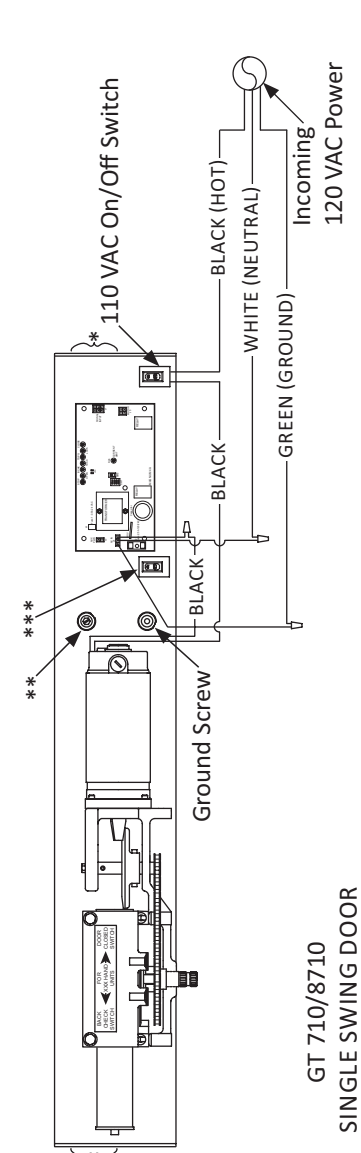

- * Notes
- ** Alternate Ground Screw
- *** Alternate 110 VAC Switch

NOTES:

- * Ensure power is OFF at Breaker.
- * Read Safety instructions within the "General Safety Recommendations" section before wiring.
- * Electrical connections must be made by qualified electrical technician.
- * Protect components from metal chips when drilling hole for electrical conduit.
- * The Control ground wire (Magnum 4A or Analog) and incoming ground wire must be connected to the same Ground screw.
- * Route Hot (Black) and Neutral (White) wires away from moving parts and other low voltage wiring.

DN 1118

SECTION 3: INSTALL THE FIRST HALF OF SWING ARM

3.1 Outswing Arm

**FOR INSWING ARMS SKIP TO
SUBSECTION 3.2**

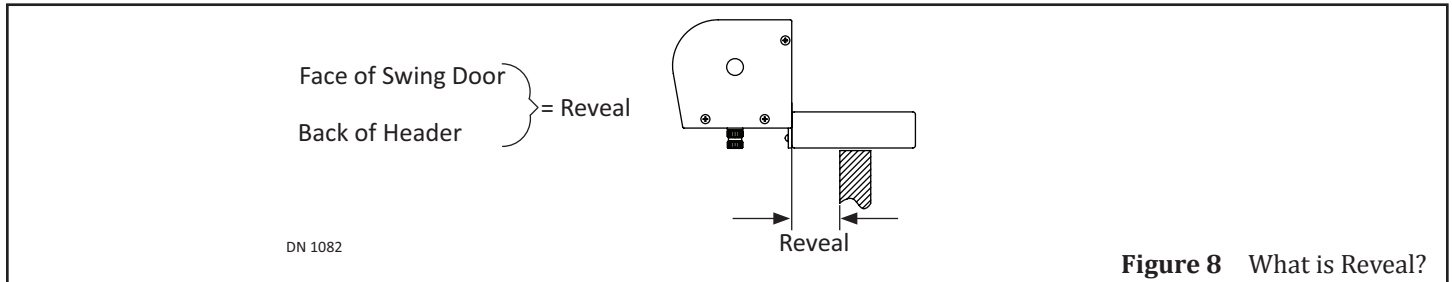

Figure 8 What is Reveal?

3.1.1: Prep the Swing Door

Table 1 Dimension "A" Arm Shoe Mounting Locations

Model	Pivot Type	Outswing	
		With Fingerguard	No Fingerguard
GT 710 & 8710	Butt/Offset	N/A	16-15/16"
	Center Pivot	N/A	16-15/16"

1. Go to Table 1 to measure the distance from the inside edge of the Pivot Door Jamb, or the Center Pivot to the center of the first Sex Bolt hole (used to attach the Arm Shoe).
2. Mark a Vertical line on the face of the Swing door.
3. At the Vertical line, measure 1-1/2 inches from the top edge of the Swing door down to the center of the Swing Door.
4. Mark a Horizontal line to cross the Vertical line. This is the center of the first Sex Bolt hole.

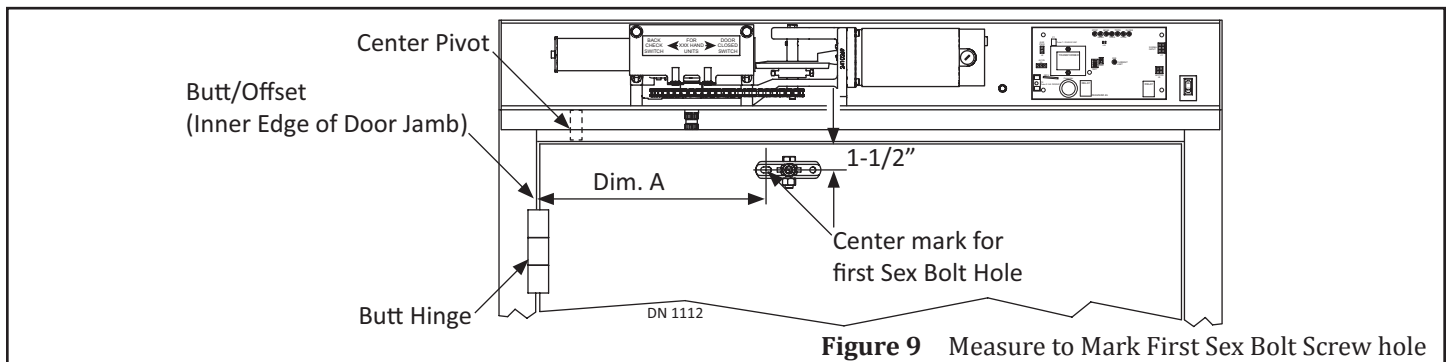

Figure 9 Measure to Mark First Sex Bolt Screw hole

3.1.2: Prep the Outswing Arm Assembly

1. Remove the Swing Arm from the Threaded Rod. Set aside.

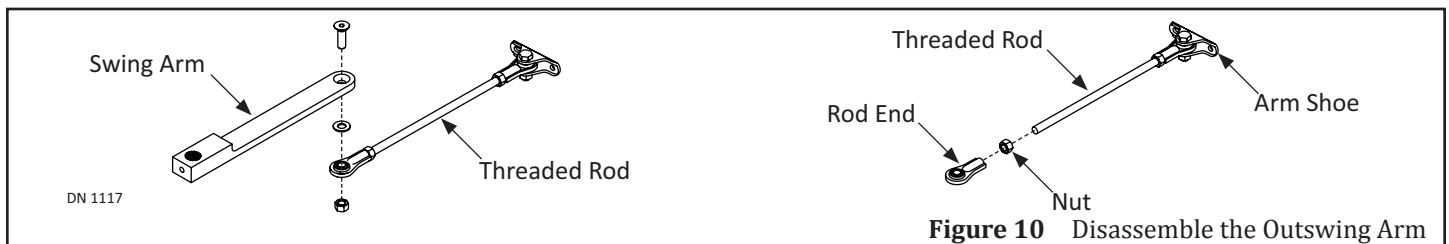

Figure 10 Disassemble the Outswing Arm

2. Go to Table 2 to locate the appropriate length measurement for the Threaded Arm.

Note: For Reveals that are 0 thru 6-1/2 inches, a 20 inch Threaded Rod must be purchased. For Reveals that are 6-3/4 inches and higher, a 30 inch Threaded Rod must be purchased.

3.1.3: Outswing Butt Hinge (Right Hand)

Side View Labels:

- "A" Reveal
- 1 3/4" (44 mm) Header Overlap
- 6 1/2" (165 mm)
- 1 1/2" (38 mm)
- 16 15/16" (430 mm)
- Fasten to door with 1/4" dia. x 3/4" long round head machine screws and sex bolts.
- Drill & fasten with 1/4" dia. x 3/4" long round head machine screws (or 1/4" dia. screws)
- Position of arm before attaching to door.
- 90°
- 18"
- See Chart "B"
- 7/8" (22 mm) dia. electrical feed hole in each end cap.
- Frame
- Door
- "A" Reveal
- "B" Arm Length

A	B
Reveal	Rod Length
0" (0 mm)	16 5/8" (422 mm)
1/4" (6 mm)	16 13/16" (427 mm)
3/8" (13 mm)	17" (432 mm)
3/4" (19 mm)	17 3/16" (437 mm)
1" (25 mm)	17 3/8" (441 mm)
1 1/4" (32 mm)	17 9/16" (446 mm)
1 1/2" (38 mm)	17 3/4" (451 mm)
1 3/4" (44 mm)	17 15/16" (456 mm)
2" (51 mm)	18 1/8" (460 mm)
2 1/4" (57 mm)	18 5/16" (465 mm)
2 1/2" (64 mm)	18 1/2" (470 mm)
2 3/4" (70 mm)	18 11/16" (475 mm)
3" (76 mm)	18 7/8" (479 mm)
3 1/4" (83 mm)	19 1/8" (486 mm)
3 1/2" (89 mm)	19 5/16" (491 mm)
3 3/4" (95 mm)	19 1/2" (495 mm)
4" (102 mm)	19 11/16" (500 mm)
4 1/4" (108 mm)	19 7/8" (505 mm)
4 1/2" (114 mm)	20 1/8" (511 mm)
4 3/4" (121 mm)	20 5/16" (516 mm)
5" (127 mm)	20 1/2" (521 mm)
5 1/4" (133 mm)	20 3/4" (527 mm)
5 1/2" (140 mm)	20 15/16" (532 mm)
5 3/4" (146 mm)	21 1/8" (537 mm)
6" (152 mm)	21 3/8" (543 mm)

Bottom View Labels:

- Frame
- Door
- "A" Reveal
- "B" Arm Length

Bottom View Legend:

- BACK CHECK
- MAIN SPEED
- LATCH SPEED

Part Numbers:

- DN0027
- DN 1121

3.1.4: Outswing Center Pivoted (Right Hand)

**Drill & fasten 1/4\"/>

**Fasten 1/4\"/>

**1 1/2\"/>

**10 3/4\"/>

**16 15/16\"/>

**1 3/4\"/>

90°

18°

Position of arm before attaching to door.

See Chart

90°

Frame

Door

"A" Reveal

"B" Arm Length (70 mm) Door Pivot

**2 3/4\"/>

**2 1/4\"/>

**2 1/2\"/>

**2 3/4\"/>

**3\"/>

**3 1/4\"/>

**3 1/2\"/>

**3 3/4\"/>

**4\"/>

**4 1/4\"/>

**4 1/2\"/>

**4 3/4\"/>

**5\"/>

**5 1/4\"/>

**5 1/2\"/>

**5 3/4\"/>

**6\"/>

0\" (0 mm)

1/4\" (6 mm)

1/2\" (13 mm)

3/4\" (19 mm)

1\" (25 mm)

1 1/4\" (32 mm)

1 1/2\" (38 mm)

1 3/4\" (44 mm)

2\" (51 mm)

2 1/4\" (57 mm)

2 1/2\" (64 mm)

2 3/4\" (70 mm)

3\" (76 mm)

3 1/4\" (83 mm)

3 1/2\" (89 mm)

3 3/4\" (95 mm)

4\" (102 mm)

4 1/4\" (108 mm)

4 1/2\" (114 mm)

4 3/4\" (121 mm)

5\" (127 mm)

5 1/4\" (133 mm)

5 1/2\" (140 mm)

5 3/4\" (146 mm)

6\" (152 mm)

0\" (0 mm)

14\" (356 mm)

14 1/4\" (362 mm)

14 7/16\" (367 mm)

14 11/16\" (373 mm)

14 1/2\" (378 mm)

15 1/8\" (384 mm)

15 5/16\" (389 mm)

15 9/16\" (395 mm)

15 3/4\" (400 mm)

16\" (406 mm)

16 1/4\" (413 mm)

16 7/16\" (418 mm)

16 11/16\" (424 mm)

16 3/8\" (429 mm)

17 1/8\" (435 mm)

17 3/8\" (441 mm)

17 9/16\" (446 mm)

17 13/16\" (452 mm)

18\" (457 mm)

18 1/4\" (464 mm)

18 1/2\" (470 mm)

18 3/4\" (476 mm)

18 15/16\" (481 mm)

19 1/16\" (487 mm)

19 3/8\" (492 mm)

DN0028
DN 1122

3. Measure the Threaded Rod between the center of each Eye, located on each Link, located at each end of the Rod. Please see Dim B in Figure 11.
4. Remove the Link that is not attached to the Arm Shoe, from the Threaded Rod.
5. Cut the Threaded Rod according to the measurement that was determined in Step 3.

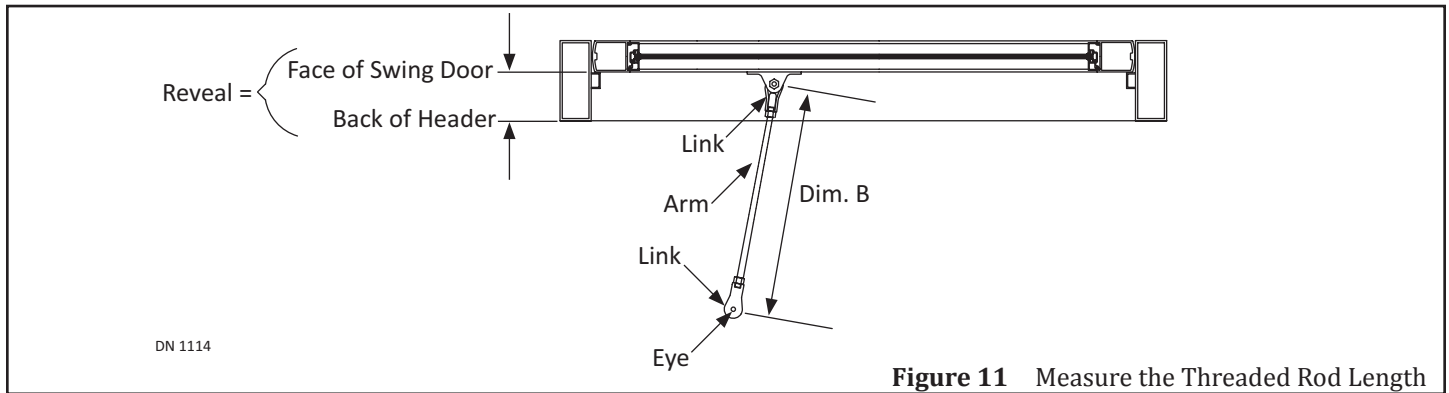

Figure 11 Measure the Threaded Rod Length

6. Obtain (1) color coordinated Plastic Tube from the Outswing Rod assembly.
7. Cut the Plastic Tube to the same length as the exposed Rod (between the Links and Nuts).
8. Slide the Plastic Tube over the Threaded Rod.
9. Replace the Rod Link back onto the Threaded Rod.
10. Tighten the Nut against the Link to prevent the Rod from screwing In or Out.

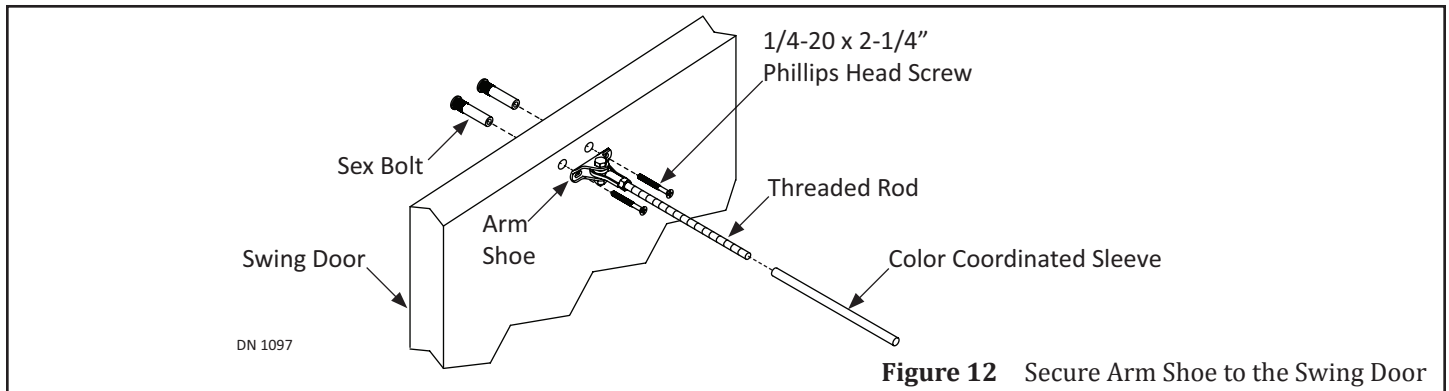

Figure 12 Secure Arm Shoe to the Swing Door

3.1.5: Secure the Arm Shoe to the Swing Door

1. Butt the Arm Shoe against the Swing door. Align the first Sex Bolt hole to the measured Mark.
2. Ensure the Arm Shoe is square and level.
3. Use the Arm Shoe as a Template to mark the second Sex Bolt hole. Set aside.
4. Drill (2) 3/8 inch bolt holes all the way through the Swing door.
5. Go to the back of the Swing door. Insert each Sex Bolt into the drilled holes.
6. Go to the front of the Swing door. Secure the Arm Shoe to the Swing Door with (2) 1/4-20 x 2-1/4" Screws.

3.2 Inswing Arm

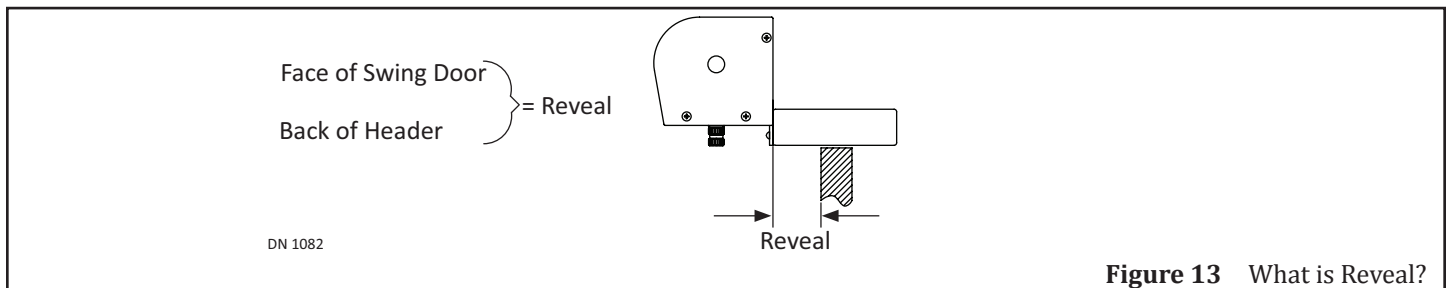

Figure 13 What is Reveal?

3.2.1: Prep the Swing Door

Note: Ensure there is a 2 inch gap between the wall and the outside face of the Swing door in the fully opened position (90 degrees).

1. Go Table 3 or Table 4 to measure the distance from the inside edge of the Pivot Door Jamb, or the Center Pivot to the center of the first Sex Bolt hole (used to attach the Track).
2. Mark a Vertical line reflecting the measured distance on the face of the Swing door.

Table 2 Small Track Mounting Locations (12-1/4 inches)

Reveal	Butt Hinge	Dim A	
		Center Pivot w/Finger Guard	Center Pivot no Finger Guard
0	7-5/8"	8-3/16"	7-3/16"
1/4"	7-3/4"	8-3/8"	7-3/8"
1/2"	7-15/16"	8-9/16"	7-9/16"
3/4"	8-1/8"	8-3/4"	7-3/4"
1"	8-5/16"	8-15/16"	7-15/16"
1-1/4"	8-1/2"	9-1/8"	8-1/8"
1-1/2"	8-11/16"	9-5/16"	8-5/16"
1-3/4"	8-7/8"	9-1/2"	8-1/2"
2"	9-1/16"	9-3/4"	8-3/4"
2-1/4"	9-1/4"	9-15/16"	8-15/16"
2-1/2"	9-1/2"	10-1/8"	9-1/8"
2-3/4"	9-11/16"	10-3/8"	9-3/8"
3"	13-1/8"	10-9/16"	9-9/16"
3-1/4"	13-3/8"	14-1/16"	13-1/16"
3-1/2"	13-9/16"	14-1/4"	13-1/4"
3-3/4"	13-3/4"	14-1/2"	13-1/2"

Reveal	Butt Hinge	Dim A		
		Center Pivot w/Finger Guard	Center Pivot no Finger Guard	
4"	14"	14-11/16"	13-11/16"	
4-1/4"	14-3/16"	14-3/4"	13-3/4"	
4-1/2"	14-7/16"	14-3/4"	13-3/4"	
4-3/4"	14-1/2"	14-3/4"	13-3/4"	
5"		14-3/4"	13-3/4"	
5-1/4"		14-13/16"	14-13/16"	13-13/16"
5-1/2"				
5-3/4"				
6"				
6-1/4"	18-1/2"			
6-1/2"				
6-3/4"	18-9/16"	18-7/8"	17-7/8"	
7"	18-9/16"	18-7/8"	17-7/8"	
7-1/4"	18-5/8"	18-15/16"	17-15/16"	
7-1/2"	18-5/8"	N/A	N/A	

Table 3 Large Track Mounting Locations (21 inches)

Reveal	Butt Hinge	Dim A		
		Center Pivot w/Finger Guard	Center Pivot no Finger Guard	
7-1/2"	N/A	14-1/2"	13-1/2"	
7-3/4"	14-1/4"	14-9/16"	13-9/16"	
8"		14-9/16"	13-9/16"	
8-1/4"		14-5/8"	13-5/8"	
8-1/2"		14-5/8"	13-5/8"	
8-3/4"		14-5/8"	13-5/8"	
9"		14-5/8"	13-5/8"	
9-1/4"		14-5/8"	13-5/8"	
9-1/2"		14-5/8"	13-5/8"	
9-3/4"		14-5/8"	13-5/8"	
10"		14-9/16"	13-9/16"	
10-1/4"		14-3/16"	14-9/16"	13-9/16"

Reveal	Butt Hinge	Dim A	
		Center Pivot w/Finger Guard	Center Pivot no Finger Guard
10-1/2"	19-1/4"	14-9/16"	13-9/16"
10-3/4"	19-1/4"	19-5/8"	18-5/8"
11"	19-1/4"	19-11/16"	18-11/16"
11-1/4"	18-9/16"		
11-1/2"	19-5/16"		
11-3/4"			
12"			
12-1/4"			
12-1/2"			
12-3/4"			
13"			

3. Go to the top edge of the Swing Door. Measure:
 - ▶ 0 inch Reveal (Straight Arm):
 - 11/16 inch from the top edge of the Swing Door down to the center of the Swing Door.
 - ▶ Reveals greater than 0 inch (L-Shape Arm):
 - 1-9/16 inch from the top edge of the Swing Door down to the center of the Swing Door.
 - ▶ New dimension not shown (L-Shape Arm):
 - Reveal + 8-7/8 inch = New dimension
4. Mark a Horizontal line to cross the Vertical line. This is the center of the first Sex Bolt hole.

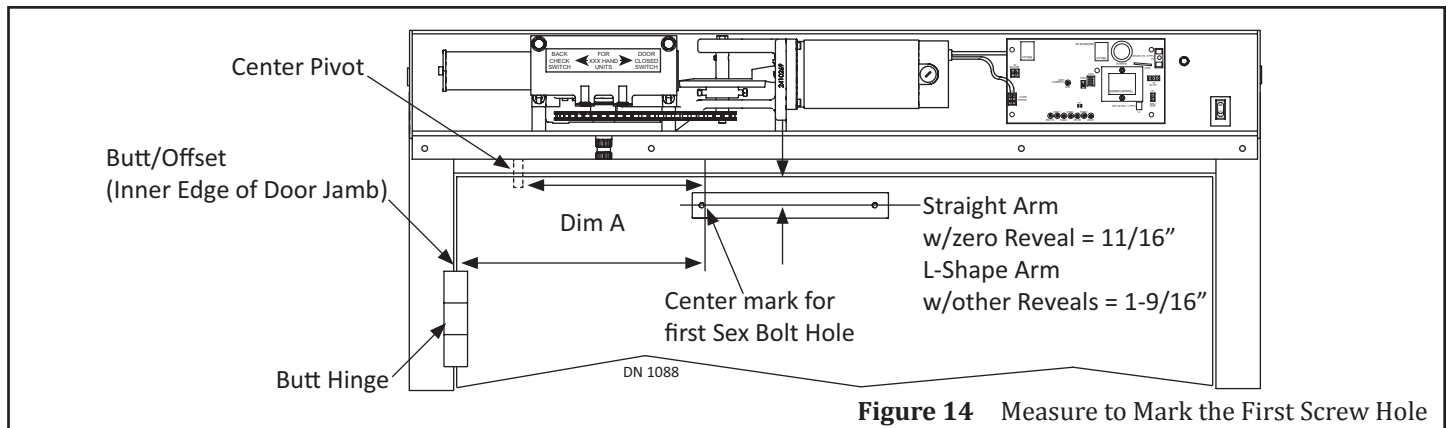

Figure 14 Measure to Mark the First Screw Hole

3.2.2: Secure the Track to the Swing Door

1. Butt the Track against the Swing door by aligning the first Sex Bolt hole with the measured Mark.
2. Ensure the Track is square and level.
3. Use the Track as a Template to mark the second Sex Bolt hole. Set aside.
4. Drill (2) 3/8 inch bolt holes all the way through the Swing door.
5. Go to the back of the Swing door. Insert each Sex Bolt into the drilled holes.
 - a. If the wall/frame is not straight, vertical, plum etc., install (1) Spacer (21-0902) behind the Track only if Reveal has a variance of zero to 1/4 inch and a Straight Arm is being installed.
 - b. A Spacer is used to prevent the Swing Arm from hitting the lip of the GT-710 Header only (the GT-8710 Header does not have a lip).
 - c. If a Spacer can not be obtained, a couple of washers can be used.
6. Go to the front of the Swing door.
7. Butt the Track against the Swing door by aligning the Sex Bolt holes.
 - a. Install (1) Spacer behind the Track for Swing doors with "0" Reveal (If required).
8. Secure the Track to the Swing Door with (2) 1/4-20 x 2-1/4" Screw.

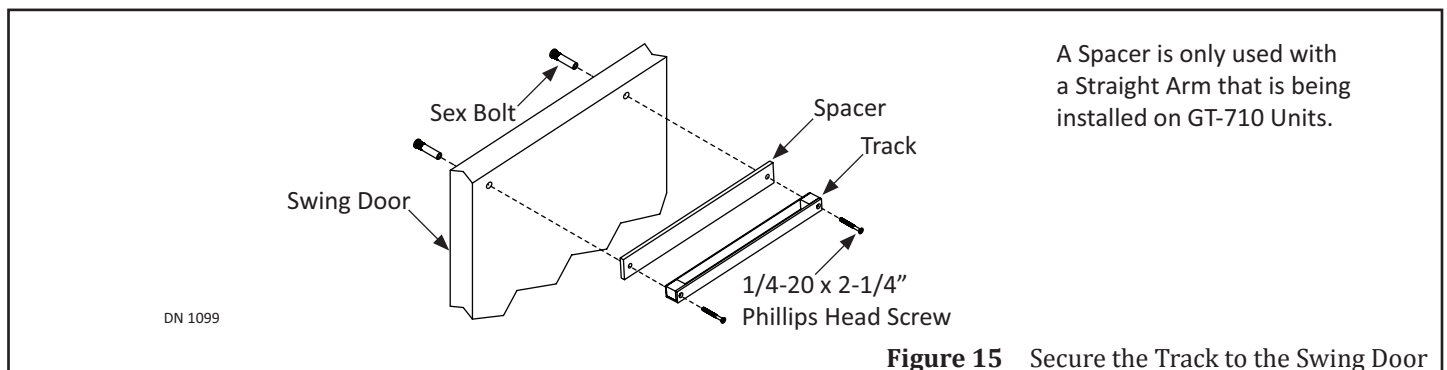

Figure 15 Secure the Track to the Swing Door

SECTION 4: INSTALL THE SECOND HALF OF SWING ARM

4.1 Set Pre-Load

WARNING

Proper Preload is critical for the Control/Operator to open/close the Swing Door correctly.

CAUTION

Power must be turned OFF during the Swing Arm installation.

1. Locate pre-load numbers 1-4 on the Bottom of the Operator Spindle.
 - a. Pre-load numbers 1-4 mark the correct installation position for pre-load.

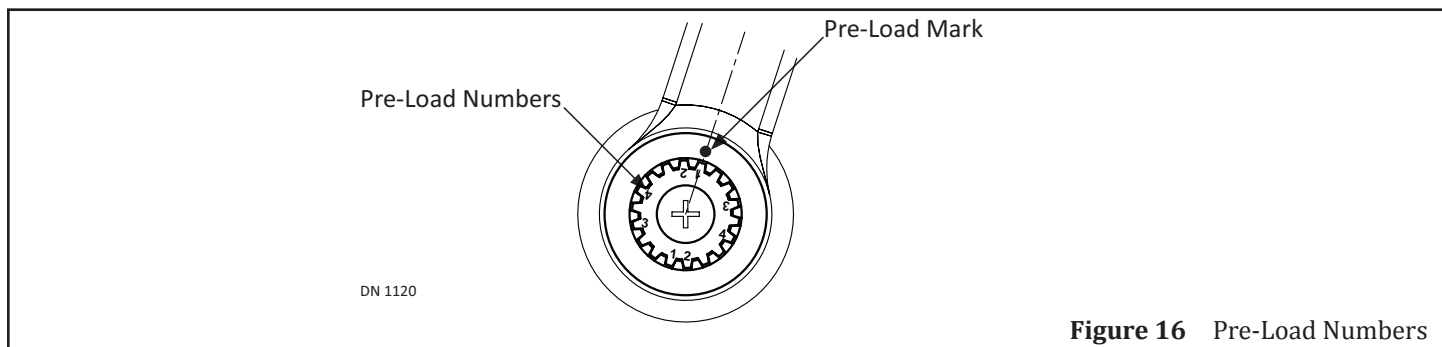

2. Obtain the Swing Arm.
3. Slide the Swing Arm onto the Operator Spindle by aligning the appropriate pre-load number to the pre-load mark on the underside of Swing Arm:

RH Outswing	LH Outswing	RH Inswing	LH Inswing	RH Inswing-0 Reveal	LH Inswing-0 Reveal
1	2	3	4	4	3

4. Please see Figure 17, or Figure 18, or Figure 19.

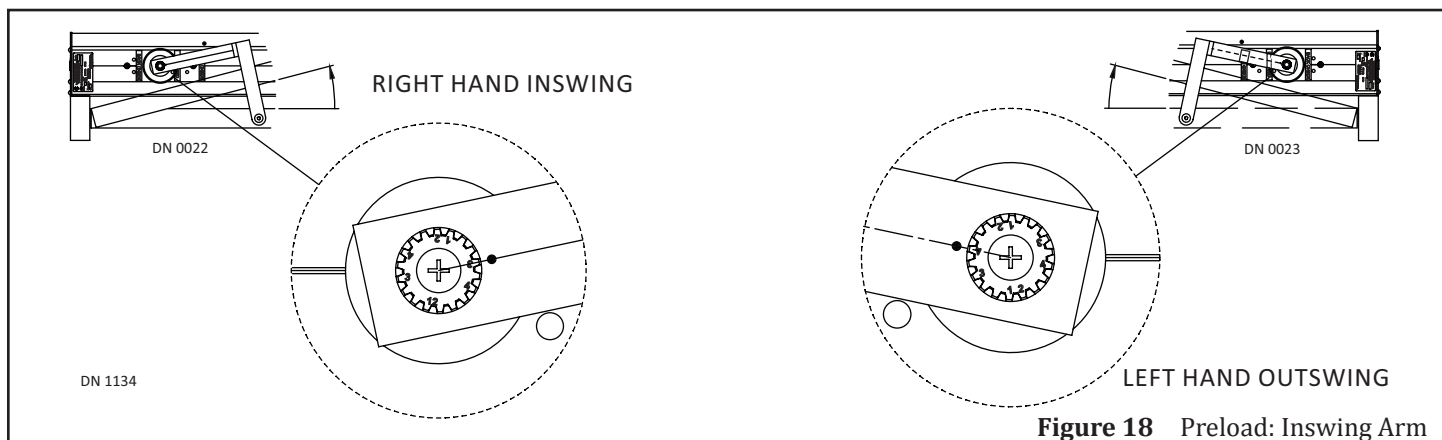

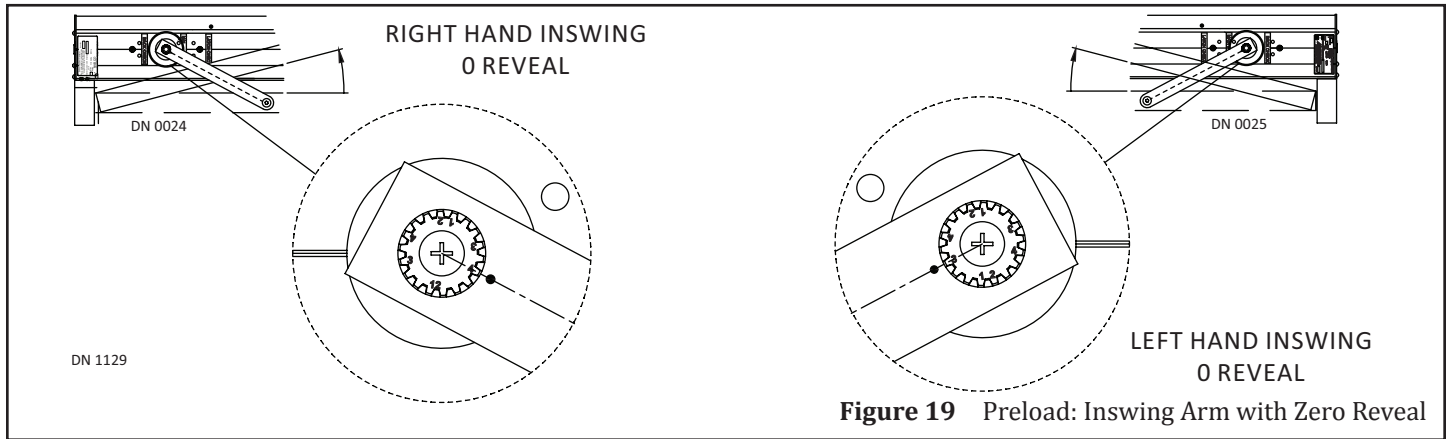

Figure 19 Preload: Inswing Arm with Zero Reveal

5. Secure the Swing Arm to the Operator Spindle with (1) Set Screw. Tighten but do not overtighten.
 - a. Ensure the Set Screw is seated correctly within the groove on the Operator Spindle.

4.2 Secure the Swing Arm to the Swing Door

4.2.1 Outswing Arm

1. Align the screw hole at the end of Swing Arm to the Rod End screw hole.
2. Pull the Swing Arm towards the Rod to connect.
3. Secure the Swing Arm to the Threaded Rod with (1) 3/8"-24 x 1-1/4" Socket Screw, (1) .405 Washer, and (1) 3/8"-24 Lock Nut.

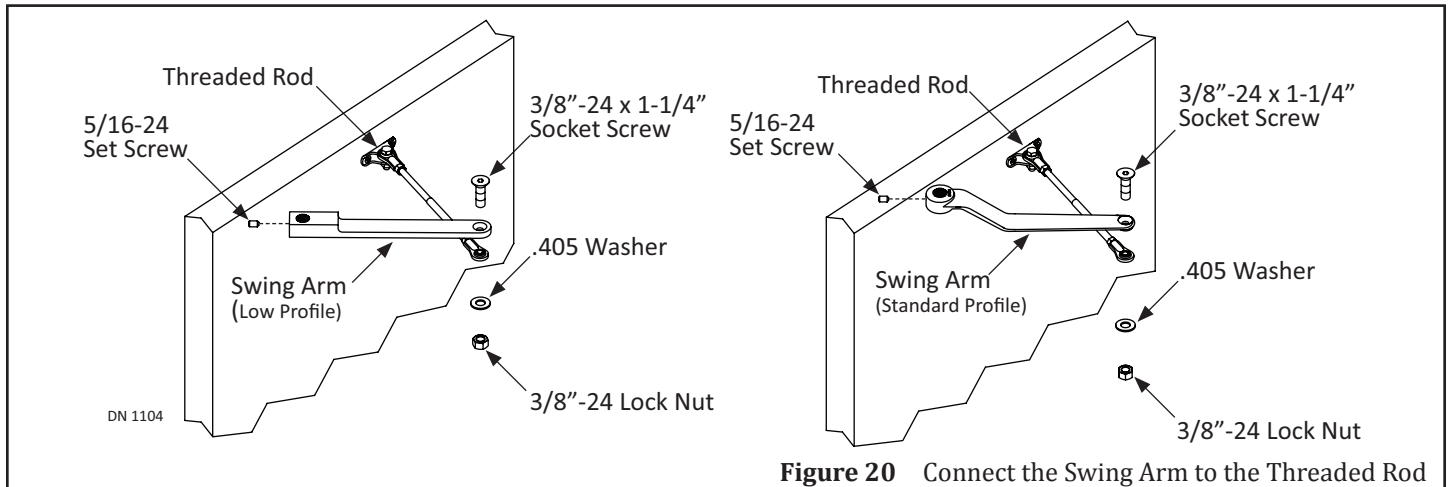

Figure 20 Connect the Swing Arm to the Threaded Rod

4.2.2 Inswing Arm

1. Remove the first 1/4-20 x 2-1/4" Screw (closest to the Pivot Door Jamb) that is used to secure the Track to the Swing door.
 - a. That side of the Track will hang down.
2. Close the Swing door to allow the Wheeled Roller (located at the end of the Swing Arm) to butt against the Swing door.
3. Pull the Swing Arm to the Swing door, then raise the Track.
4. Secure the Track to the Swing door with (1) 1/4-20 x 2-1/4" Screw.

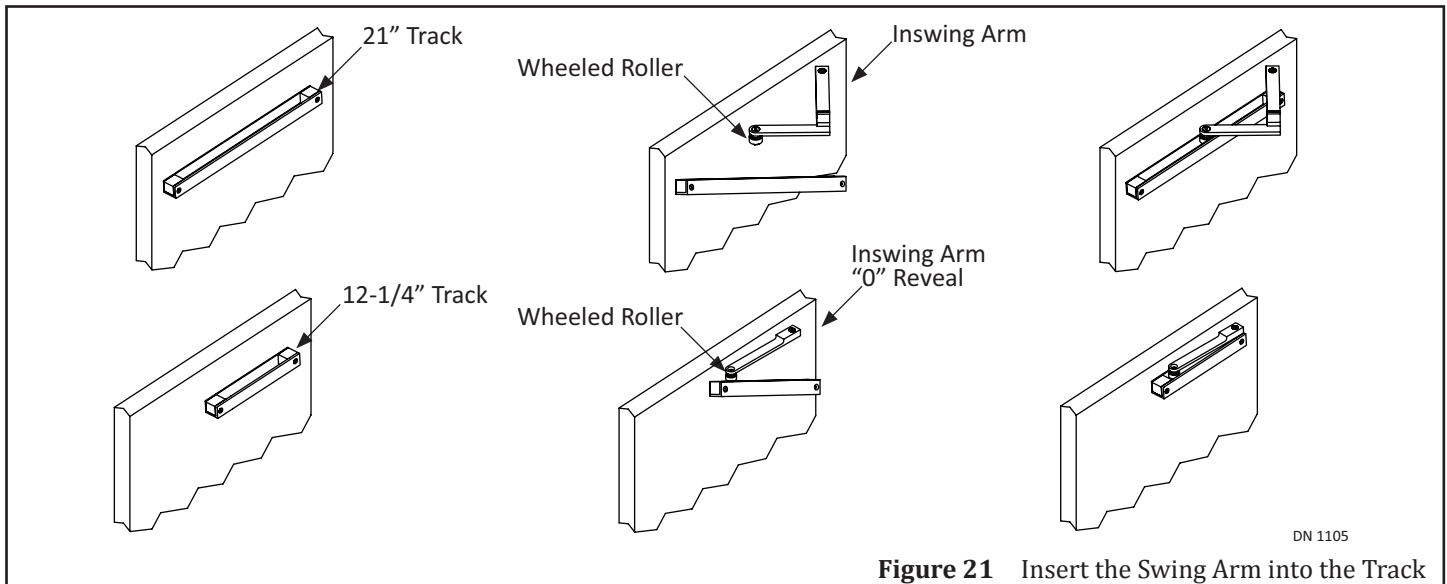

Figure 21 Insert the Swing Arm into the Track

SECTION 5: INSTALL THE MAGNETS

CAUTION

Power must be turned OFF while installing the Magnets.

Note: Magnetic Reed Switches are reversed according to Handing of door (LH vs RH).

When Magnets are correctly set, the Green LED on the Magnum 4A Control will be:

- ▶ OFF when the door is closed.
- ▶ Fast Flashing when opening.
- ▶ On Solid at Back Check.
- ▶ Slow flashing when closing.
- ▶ OFF again at Latch Check

1. Go to the Magnum 4A Control. Disconnect Power.
2. Unplug the J4 Connector.
3. Set the Current Limit Switch to Maximum. (Clockwise)

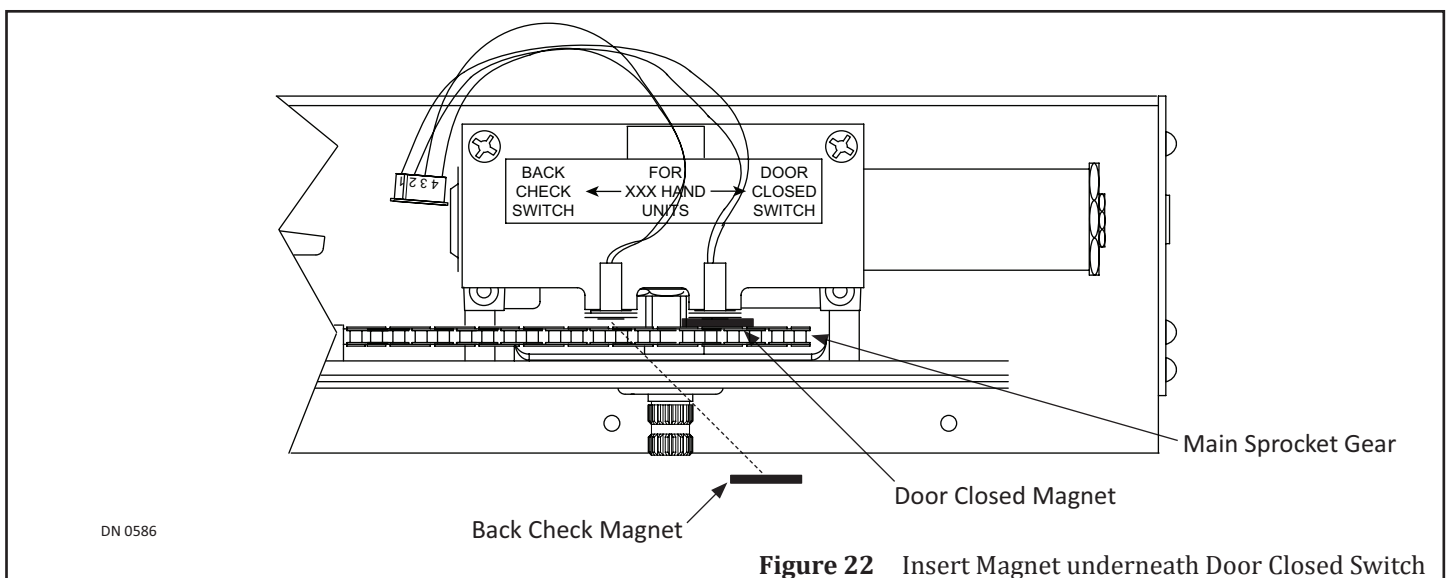

Figure 22 Insert Magnet underneath Door Closed Switch

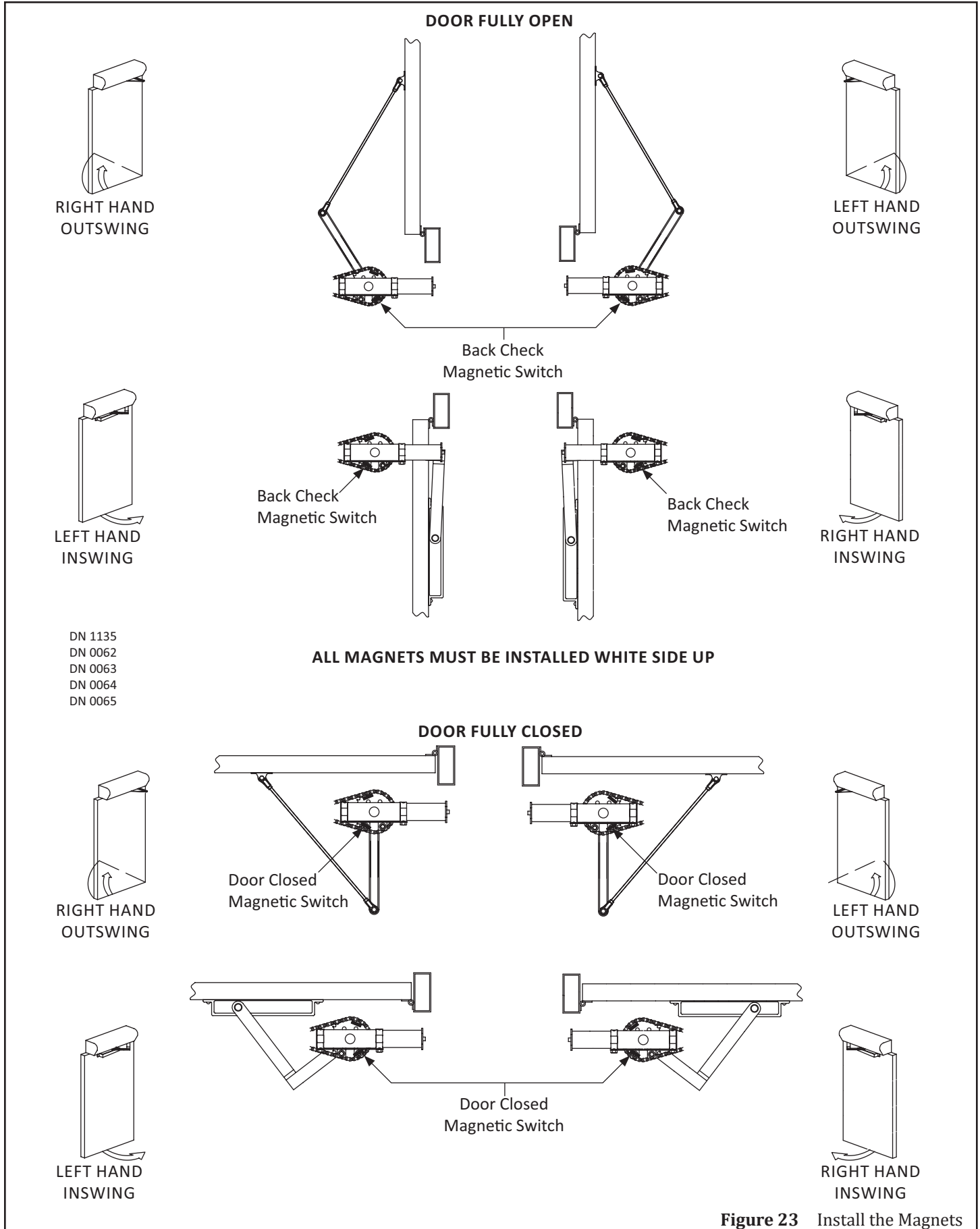

Figure 23 Install the Magnets

5.1 Insert the Back Check Magnet

When the Magnet is correctly set, the Green LED on the Magnum 4A Control will be:

- ▶ ON steady when the Swing door is in the fully Open position after an activation.

1. Obtain (1) 1/4 inch square x 1 inch long Magnet.
2. Manually open the Swing door to the Fully Open position (90 degrees).
3. Place the Magnet (White side up) directly underneath the Back Check Magnetic Switch.

5.2 Insert The Latch Check Magnet

When the Magnet is correctly set, the Green LED on the Magnum 4A Control will be:

- ▶ OFF when the Swing door is in the fully Closed position.

1. Obtain (1) 1/4 inch square x 1 inch long Magnet.
2. Manually Close the Swing door to the Fully Closed position (0 degrees).
3. Place the Magnet (White side up) directly underneath the Door Closed Magnetic Switch.

5.2.1 Test the Magnets

Note: If the Back Check magnet is installed with the Swing door fully open (90°), opening speed does not need to be adjusted.

1. Turn Power ON.
2. Electronically close the Swing door.
 - a. As the Swing door closes to the 15 degree mark, the Door Closed Magnet starts to rotate underneath the "Door Closed" Magnetic Reed Switch. The Swing door will start to slow down.
 - b. At the 0 degree mark, the Latch Check Magnet is fully underneath the Door Closed Magnetic Switch.
3. Relocate the Magnet if adjustment is deemed necessary.

SECTION 6: INSTALL THE ARM STOP

CAUTION

Power must be turned OFF while installing the Arm Stop.

CAUTION

Do Not drill screw holes for the Arm Stop into the Motor/Operator!!!

1. Turn Power OFF.
2. Manually open the Swing Door 90 degrees.
3. Position the Arm Stop at the bottom of Header according to type of Swing Arm and Reveal shown in Figure 24.
4. Use the Arm Stop as a template to mark and drill (2) 7/32 inch diameter screw holes.
5. Secure the Arm Stop with (2) 1/4-20 x 1 inch Self Tapping screws.

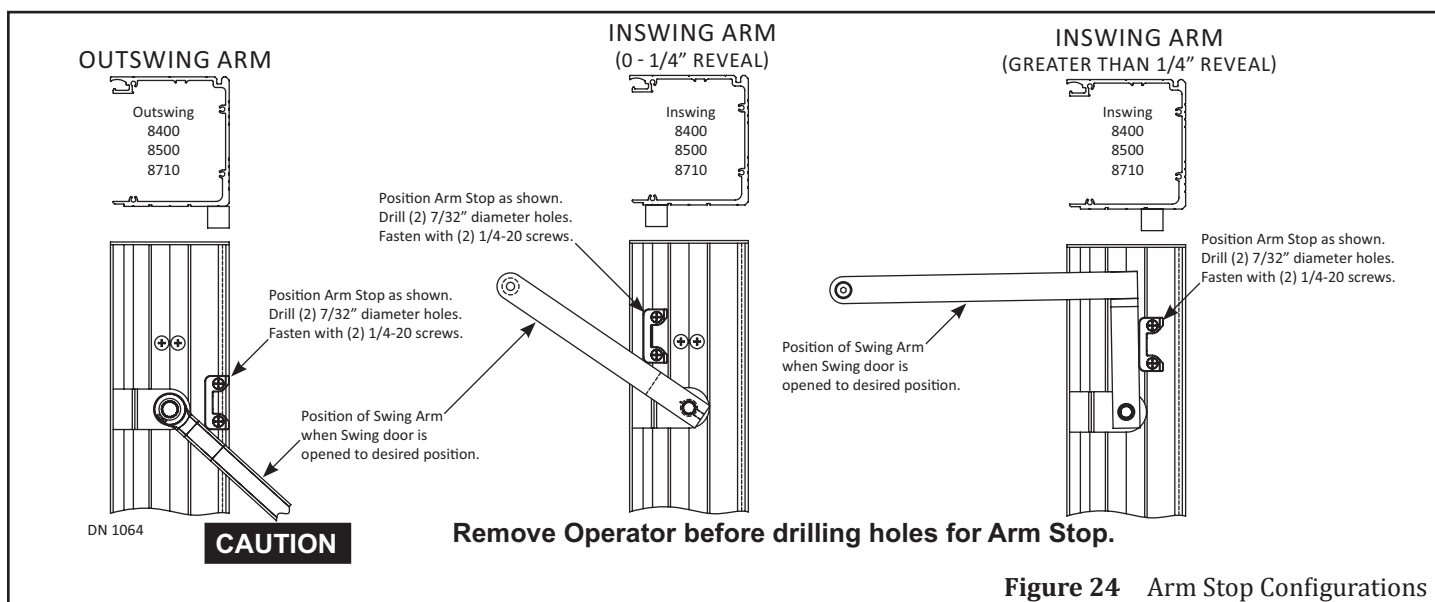

SECTION 7: MAGNUM GENERAL WIRING

7.1.1: GT-710-8710 Single Swing Door

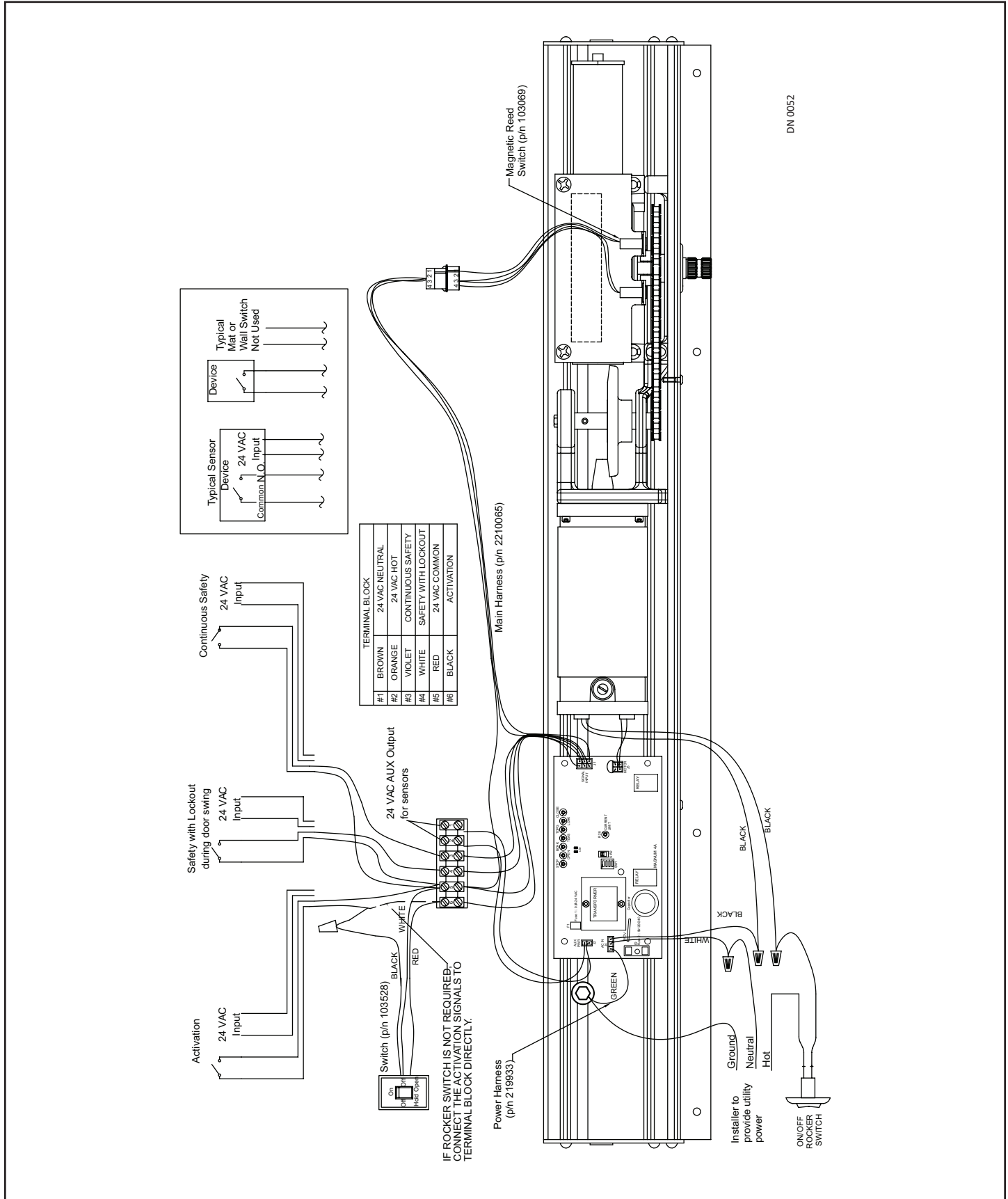

7.1.2: GT-710-8710 Simultaneous Pair Swing Door

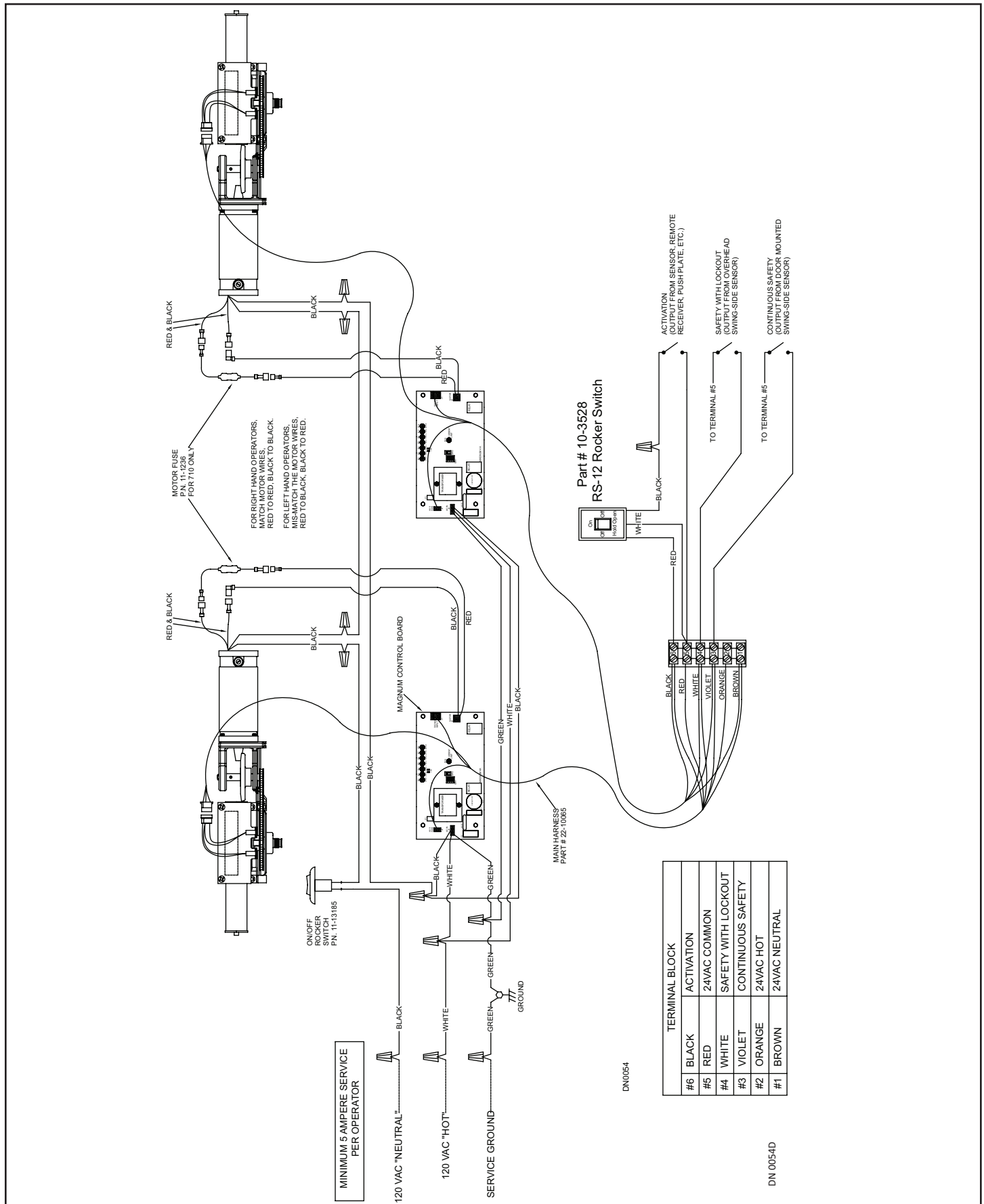

SECTION 8: ADJUSTMENTS

8.1 LCN Tension Spring

WARNING

Improperly installed/adjusted Tension Springs may cause property damage or personal injury. Please follow instructions carefully.

CAUTION

Opening Force must be properly adjusted on the LCN Tension Spring - BEFORE - the Magnum 4A Control can be adjusted.

8.1.1 Adjust Opening/Closing Force (Manual Mode)

The LCN Tension Spring is used to adjust Opening/Closing Force when the Swing door is used Manually. The Factory preset force is ideal in most cases. Adjustment should only need to be done in special cases.

1. Turn Power OFF.
2. Insert 5/32 Allen Wrench in the Screw located at the end of the LCN Tension Spring.
 - a. The Spring should be adjusted so that the Swing door can be easily pushed open, but still have enough force to fully close the Swing door.
3. To Increase Opening/Closing Force, turn the 5/32 Allen wrench clockwise not more than (9) full turns.
4. To Decrease Opening/Closing Force, turn the 5/32 Allen wrench counterclockwise not more than (4) full turns.

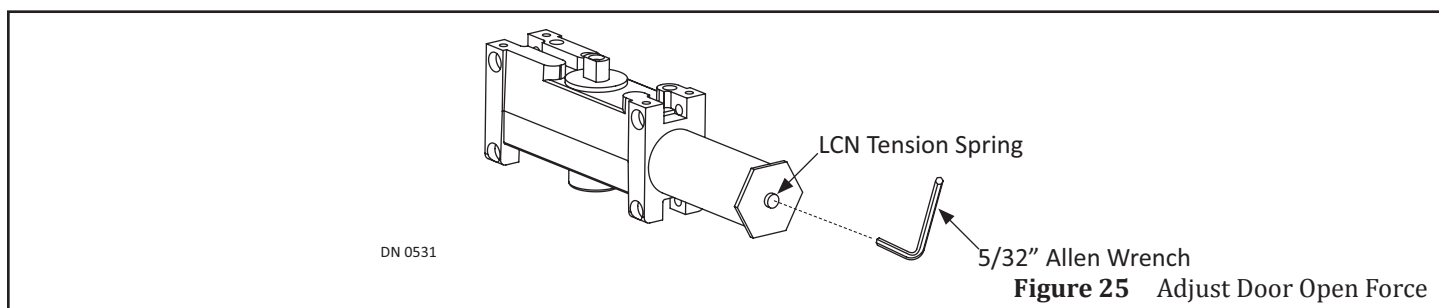

8.2 Hydraulic Speed Control (Automatic Mode)

Note: The Close and Latch Potentiometers located on the Magnum 4A Control is disabled and has no effect.

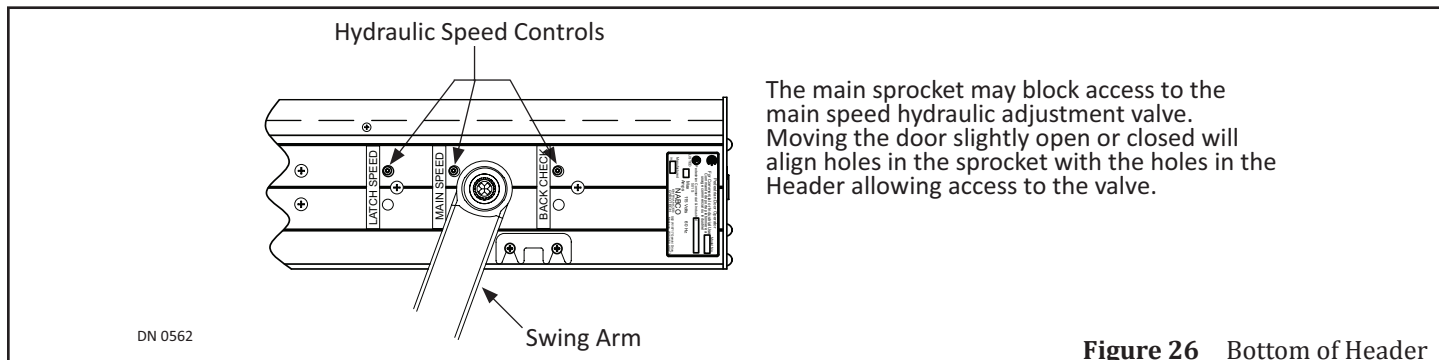

8.2.1: Adjust Main Speed

1. Turn Power OFF.
2. Insert 3/32 Allen Wrench into the Main Speed adjustment hole.
 - a. If the adjustment hole is blocked by the sprocket, slightly close the Swing door until the adjustment Valve can be accessed.
3. Turn the Allen Wrench clockwise to slow down closing speed.

8.2.2: Adjust Latch Speed

1. Turn Power OFF.
2. Insert 3/32 Allen Wrench into the Latch Speed adjustment hole.

3. Turn the Allen Wrench clockwise to slow down Latch Check speed.
4. Manually push the Swing door open, then let it close.
5. Test Latch Check speed. Re-adjust if necessary.

8.2.3: Adjust Back Check Speed

This adjustment should not be confused with the Back Check (BCHK) setting located on the Magnum 4A control. BCHK determines the amount of power applied to the motor to push the door open through Back Check.

1. Turn Power OFF.
2. Insert Allen Wrench into the Latch Speed adjustment hole.
3. Turn Allen Wrench clockwise to increase hydraulic tension at back check.
4. Manually push the Swing door open.
5. Test Back Check speed. Re-adjust if necessary.

8.3 Magnum Control Adjustments

Before adjusting speeds:

- ▶ Set the Current Limit to maximum
- ▶ Adjust the Open-Close-Check speeds
- ▶ Adjust current limit to the proper level

Table 4 Dip Switch Information

Dip Switch	ON Position	OFF Position
1	Not Used	Not Used
2	Normally Open Safely	Normally Closed Safely
3	Push-N-Go Inactive	Push-N-Go Active
4	Timer Mode	Sequential Mode

Table 5 Slide Switch

Position	Function
UP	Low Energy (GT-710 & 8710)
DOWN	High Energy (GT-300 & 400 only); Door opens faster

Table 6 Potentiometers and Functions

Potentiometer	Function
STOP	<ul style="list-style-type: none"> ▶ Adjusts how door reacts to continuous safety input (terminal # 3) during Opening. Counterclockwise = door slowly closes, Clockwise = door creeps open ▶ For Magnum 4 and 4A only: After 8 seconds of the door being held open, motor voltage is lowered to reduce stress on motor and control. "stop" will adjust this reduced voltage.
OPEN	Adjusts opening speed. Clockwise = Faster
BCHK	Adjusts Back Check speed. Clockwise = Faster
TDAS	Adjusts how long door remains open after activation signal. Clockwise = Longer
TDPG	Adjusts how long door remains open after Push-N-Go. Clockwise = Longer
LCHK	Adjusts Latch Check speed. Clockwise = Faster
CLOSE	Adjusts closing speed. Clockwise = Faster
Current Limit	Adjusts how hard the door will push against an obstacle (while opening) before recycling. Clockwise = less sensitive

Table 7 Magnum Control LED Information

LED Color	LED Status	Door Status
Green	Fast Flashing (2 flashes per second)	Door is opening.
	On Steady	Door is in Back Check.
	Slow Flashing (1 flash per second)	Door is closing.
	Off	Door is in Latch Check or Closed
Red	Indicator	
	Slow Flashing (1 flashes per second)	Continuous Safety Activated
	Fast Flashing (2 flashes per second)	Safety with Lockout Activated
	On Solid	Recycle Activated

SERVICE PARTS: GT 710 LOW ENERGY HEADER

* Sold in Parts Bag 12-5662-01

** Sold in Parts Bag 12-11358

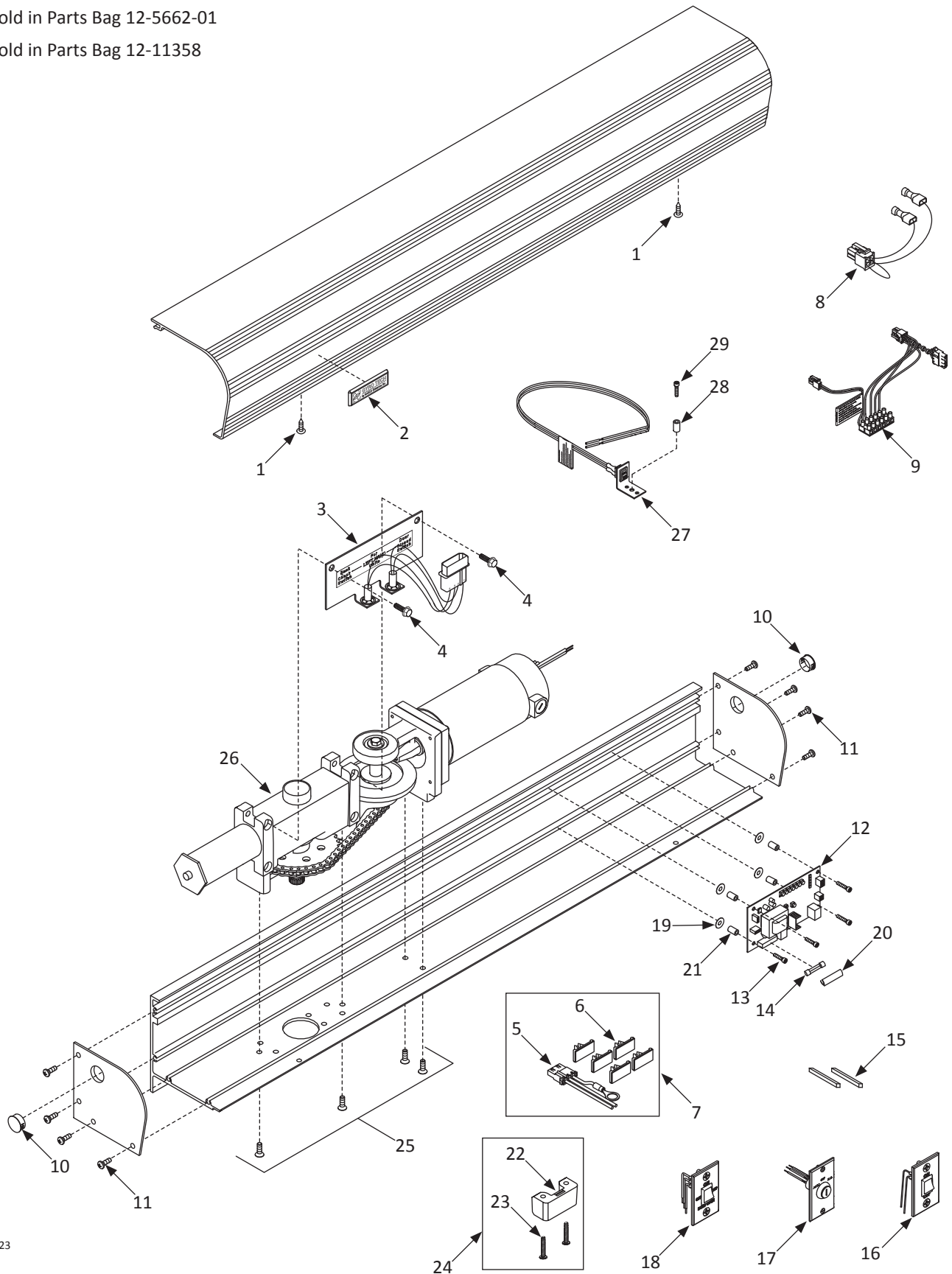

DN 1123

GT 710 Low Energy Header			
Item	Part	Finish/Sizes/Notes	Description
1	24-0094-04		SCREW, PHLLPS PAN HD MACH #8 X 5/8" AB
	24-0094-16		SCREW, PHLLPS PAN HD MACH #8 X 5/8" AB
2	14-9199		NAMEPLATE, ADHESIVE BACKED
3	21-9941-01	RH	MAGNETIC SWITCH SUB-ASSY, RH
	21-9941-02	LH	MAGNETIC SWITCH SUB-ASSY, LH
4	24-4941-19		HHMS,WASHR,5/16-18 X 1" TYPE F
5	22-1774		PWR HARNESS - SWGR & SLDR-UL PART
6	14-9960		SADDLE WIRE
7	22-0779		POWER HARNESS ASSY - SWINGER
8	11-10286		MOTOR HARNESS ASSY, GT710
9	22-10065	Single Swing Door	HARNESS ASSY - MAGNUM, SINGLE
	22-10270	Simultaneous Pair Swing Door	MAGNUM HARNESS ASSY, SIM PAIR
10	14-9511-04		PLUG, HOLE, .813 DIAMETER, BLK
11	24-0015-61	Zinc	RHMS,1/4-20 X 3/4" PHIL, TYPE F, ZN
	24-0015-62	Dark Bronze	RHMS,1/4-20 X 3/4"PHIL,SELFTAP
12	24-9800		MAGNUM CONTROL BOARD
13	24-0010-03		SHCS, 10-24 X 1
14	14-9470	Magnum 4A only	FUSE, MC
	14-11862	Magnum 1-4 only	FUSE 5 AMP
15	14-9943		MAGNET, CERAMIC 1/4" SQUARE X 1"
16	10-3527		LE RS-11 ON/OFF RCKR SWITCH ASY W/FPLT
17	22-1772-03		KEY SWITCH KS-14 3 POSITION
	22-1772-05		KEY SWITCH KS-16 2 POS MOMENTARY
18	10-3528		LE RS-12 ON/OFF/HLD OPN RCKR SWITCH ASY
19	24-0017-47		WASHER, 156 ID X .750 OD X .020 THK
20	14-10015	Magnum 1-4 only	FUSE COVER
21	14-8743		SPACER - NYLON #10 X 5/8 3/8 OD
22	14-11586		ARM STOP 710
23	24-4941-21		PHMS,PHIL,1/4-20 X1 1/2" TYPE F
24	14-12073		ARM STOP ASSEMBLY FOR SIDELOAD
25	24-0011-13		FHMS, 1/4-20 X 3/4", PHIL, ZN
	24-0011-96		FHMS,1/4-20 X 3/4,PHIL
26	22-10311-01	RH	OPER.ASM,GT710,RH
	22-10311-02	LH	OPER.ASM,GT710,LH
27	11-13185		POWER SWITCH ASSY, SWINGERS / 710
28	14-8743		SPACER - NYLON #10 X 5/8 3/8 OD
29	24-0010-01		SHCS,10-24 X 7/8CAD-UL PART

SERVICE PARTS: GT 8710 LOW ENERGY HEADER

* Sold in Parts Bag 12-5662-01

** Sold in Parts Bag 12-11358

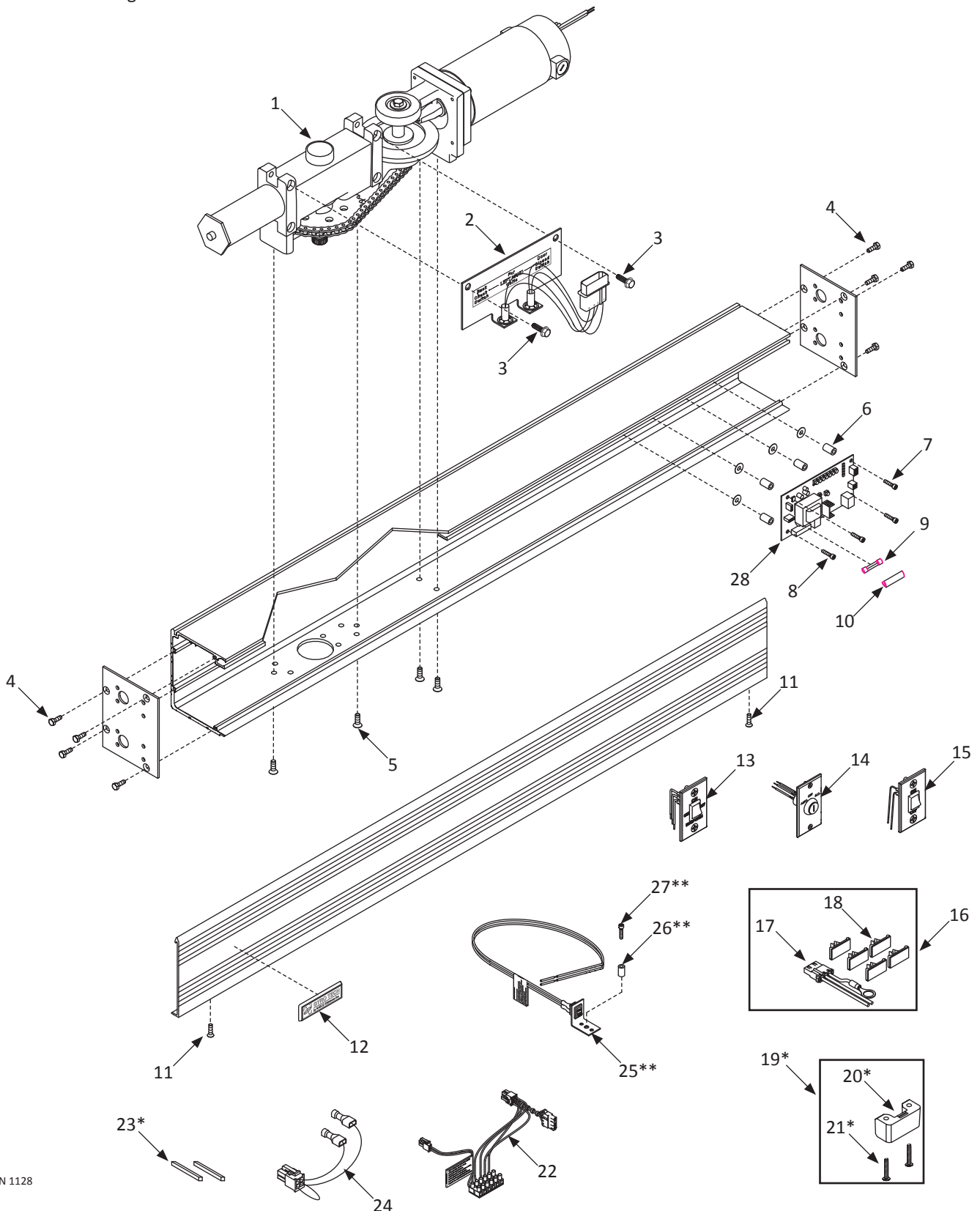

DN 1128

GT 8710 Low Energy Header				
Item	Part	Finish/Sizes/Notes		Description
1	22-10311-01	RH		OPER.ASM,GT710,RH
	22-10311-02	LH		OPER.ASM,GT710,LH
2	21-9941-01	RH		MAGNETIC SWITCH SUB-ASSY, RH
	21-9941-02	LH		MAGNETIC SWITCH SUB-ASSY, LH
3	24-4941-19			HHMS,WASHR,5/16-18 X 1" TYPE F
4	24-0011-70	Zinc		FHMS, 1/4-20 X 7/16", PHIL, UND, ZN
	24-0011-73	Black Onix		FHMS,1/4-20 X 7/16", PHIL, UND, BLK OX
5	24-0011-13			FHMS, 1/4-20 X 3/4", PHIL, ZN
	24-0011-96			FHMS,1/4-20 X 3/4,PHIL
6	14-8743			SPACER - NYLON #10 X 5/8 3/8 OD
7	24-0017-47			WASHER, 156 ID X .750 OD X .020 THK
8	24-0010-03			SHCS, 10-24 X 1
9	14-9470	Magnum 4A only		FUSE, MC
	14-11862	Magnum 1-4 only		FUSE 5 AMP
10	14-10015	Magnum 1-4 only		FUSE COVER
11	24-0094-04			SCREW, PHLLPS PAN HD MACH #8 X 5/8" AB
12	14-9199			NAMEPLATE, ADHESIVE BACKED
13	10-3528			LE RS-12 ON/OFF/HLD OPN RCKR SWITCH ASY
14	22-1772-03			KEY SWITCH KS-14 3 POSITION
	22-1772-05			KEY SWITCH KS-16 2 POS MOMENTARY
15	10-3527			LE RS-11 ON/OFF RCKR SWITCH ASY W/FPLT
16	22-0779			POWER HARNESS ASSY - SWINGER
17	22-1774			PWR HARNESS - SWGR & SLDR-UL PART
18	14-9960			SADDLE WIRE
19	14-12073			ARM STOP ASSEMBLY FOR SIDELOAD
20	14-11586			ARM STOP 710
21	24-4941-21			PHMS,PHIL,1/4-20 X1 1/2" TYPE F
22	22-10065	Single Swing Door		HARNESS ASSY - MAGNUM, SINGLE
	22-10270	Simultaneous Pair Swing Door		MAGNUM HARNESS ASSY, SIM PAIR
23	14-9943			MAGNET, CERAMIC 1/4" SQUARE X 1"
24	11-10286			MOTOR HARNESS ASSY, GT710
25	11-13185			POWER SWITCH ASSY, SWINGERS / 710
26	14-8743			SPACER - NYLON #10 X 5/8 3/8 OD
27	24-0010-01			SHCS,10-24 X 7/8CAD-UL PART
28	24-9800			MAGNUM CONTROL BOARD

SERVICE PARTS: LOW ENERGY SWING ARM ASSEMBLIES

Inswing Arm Reveal *Equal* to 0 degrees

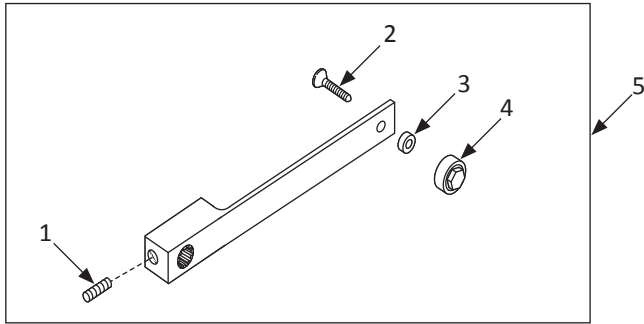

Outswing Arm Assembly

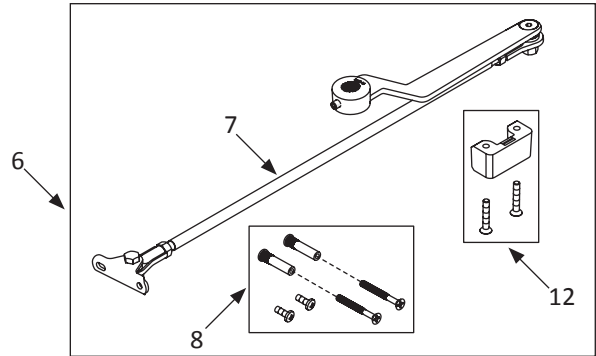

(CU) Inswing Arm Assembly Reveal Greater than 0 inches

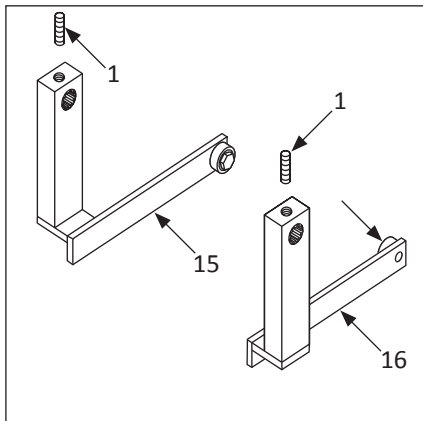

Low Profile Outswing Arm Assembly

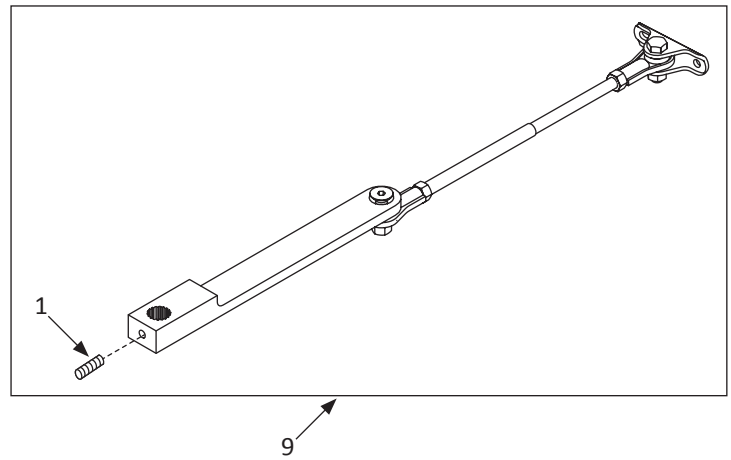

Inswing Track Assembly

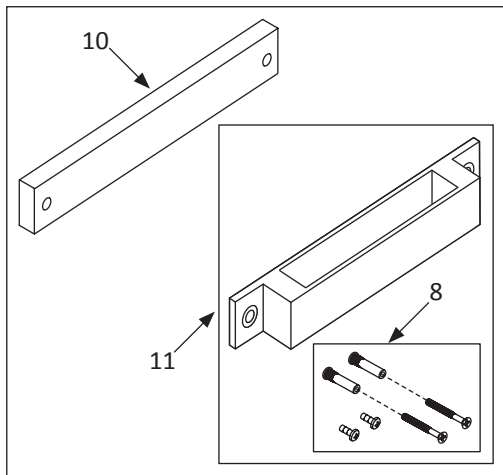

Arm Stop Assembly

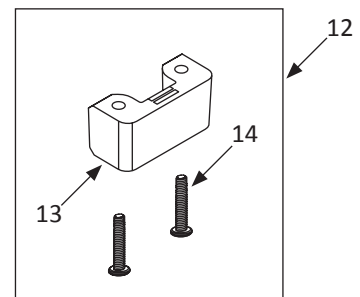

DN 1073

Low Energy Swing Arm Assemblies				
Item	Part	Finish/Sizes/Notes	Description	
1	24-0016-33		SCREW, SET 5/16-24 X 1/2, CUP POINT	
2	24-0011-15		SCREW, 3/8"-24 X 1.25 LG, FHCS, ZINC	
3	24-0017-07		WASHER, 3/8 ID X 3/4 OD X.375 THK ZINC	
4	11-1935		REPLACEMENT ROLLER ASSY	
5	21-0902-01	Clear	CU - INSWING ARM, NON PANIC NH 204	
	21-0902-02	Dark Bronze	CU - INSWING ARM, NON PANIC NH 313	
6	22-13992-41	Clear	KIT,SWINGER ARM 20 IN.204	
	22-13992-42	Dark Bronze	KIT,SWINGER ARM 20 IN.313	
	22-13992-51	Clear	KIT,SWINGER ARM 30 IN.204	
	22-13992-52	Dark Bronze	KIT,SWINGER ARM 30 IN.313	
7	21-8848-41	Clear	OUTSWING ARM ASSY, 20" ROD, 204	
	21-8848-42	Dark Bronze	OUTSWING ARM ASSY, 20" ROD, 313	
	21-8848-51	Clear	OUTSWING ARM ASSY, 30" ROD, 204	
	21-8848-52	Dark Bronze	OUTSWING ARM ASSY, 30" ROD, 313	
8	12-1355	Clear	PARTS BAG, TRACK & ARM CU GUIDE CLEAR	
	12-1355-02	Dark Bronze	PARTS BAG, TRACK & ARM CU GUIDE BRONZE	
9	21-10546-41	Clear	C.U. OUTSWING ARM ASSY, 20" THREADED ROD	
	21-10546-42	Dark Bronze	C.U. OUTSWING ARM ASSY, 20" THREADED ROD	
	21-10546-51	Clear	C.U. OUTSWING ARM ASSY, 30" THREADED ROD	
	21-10546-52	Dark Bronze	C.U. OUTSWING ARM ASSY, 30" THREADED ROD	
10	14-5806		SPACER, TRACK - 1/4" X 12-1/4" BLK	
11	21-0997-01	Clear	CU - GUIDE TRACK ASSY 12.25" 204	
	21-0997-02	Dark Bronze	CU - GUIDE TRACK ASSY 12.25" 313	
	21-0998-01	Long/Clear	CU - GUIDE TRACK ASSY 21" 204	
	21-0998-02	Long/Dark Bronze	CU - GUIDE TRACK ASSY 21" 313	
12	14-12073		ARM STOP ASSEMBLY FOR SIDELOAD	
13	14-11586		ARM STOP 710	
14	24-4941-21		PHMS,PHIL,1/4-20 X1 1/2" TYPE F	
15	21-10329-11	LH/Clear	ARM, INSWING LH 204 REVEAL 0-2	
	21-10329-12	LH/Dark Bronze	ARM, INSWING LH 313 REVEAL 0-2	
	21-10329-21	LH/Clear	ARM, INSWING LH 204 REVEAL 2-5 1/2	
	21-10329-22	LH/Dark Bronze	ARM, INSWING LH 313 REVEAL 2-5 1/2	
	21-10329-31	LH/Clear	ARM, INSWING LH 204 REVEAL 5 1/2-9 3/4	
	21-10329-32	LH/Dark Bronze	ARM, INSWING LH 313 REVEAL 5 1/2-9 3/4	
	21-10329-41	LH/Clear	ARM, INSWING LH 204 REVEAL 9 3/4-13	
	21-10329-42	LH/Dark Bronze	ARM, INSWING LH 313 REVEAL 9 3/4-13	
	16	21-10329-51	LH/Clear	ARM, INSWING RH 204 REVEAL 0 - 2
		21-10329-52	LH/Dark Bronze	ARM, INSWING RH 313 REVEAL 0 - 2
21-10329-61		LH/Clear	ARM, INSWING RH 204 REVEAL 2 - 5 1/2	
21-10329-62		LH/Dark Bronze	ARM, INSWING RH 313 REVEAL 2 - 5 1/2	
21-10329-71		LH/Clear	ARM INSWING RH 204 REVEAL 5 1/2- 9 3/4	
21-10329-72		LH/Dark Bronze	ARM INSWING RH 313 REVEAL 5 1/2- 9 3/4	
21-10329-81		LH/Clear	ARM INSWING RH 204 REVEAL 9 3/4 - 13	
21-10329-82		LH/Dark Bronze	ARM INSWING RH 313 REVEAL 9 3/4 - 13	