

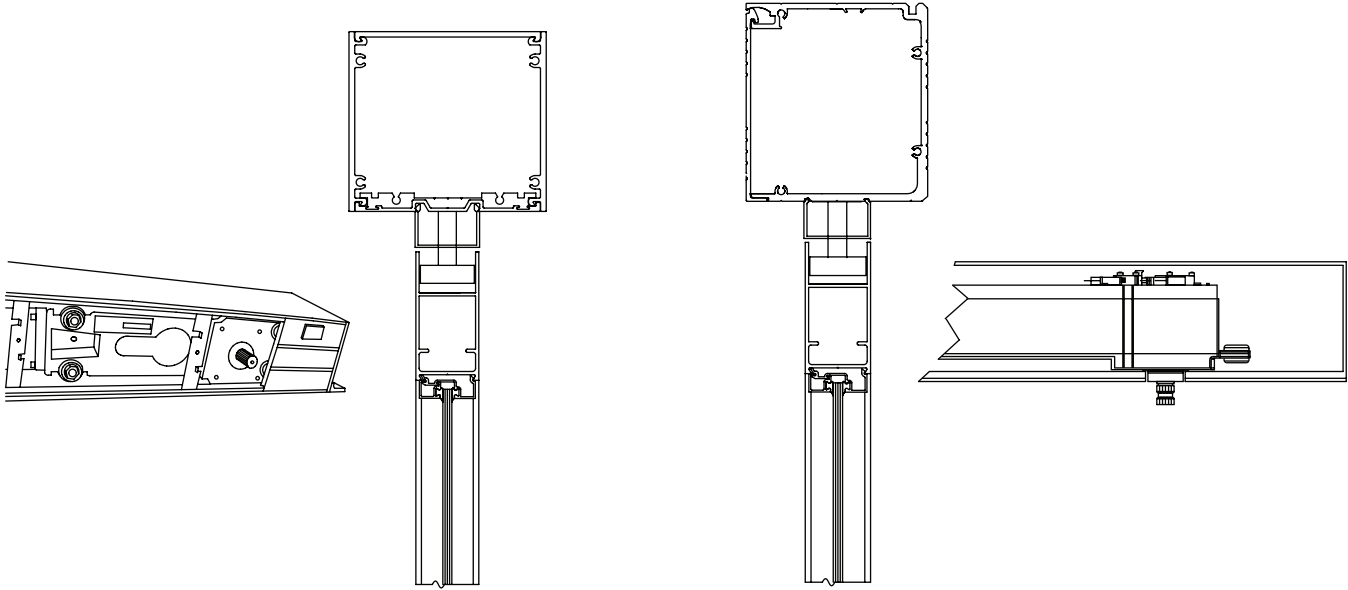


S82 W18717 Gemini Drive  
 Muskego, Wisconsin 53150  
 Phone: (877) 622-2694  
 Fax: (888) 679-3319  
 www.nabcoentrances.com  
 Technical Support: (866) 622-8325

## Overhead Concealed Swing Door Systems

Bottom Load Models: GT 300 and GT 350

Side Load Models: GT 8300 and GT 8350



GT 300  
 GT 350

GT 8300  
 GT 8350

DN 0376

**WARNING**  
 Do Not install or service this product unless Safety Practices, Warning Labels, Installation instructions, and Operating Instructions, have been read and fully understood.  
 Failure to so do may result in bodily injury or property damage.

**THIS PAGE IS INTENTIONALLY LEFT BLANK**

## Table of Contents

*Warning Labels* . . . . . iii

*General Safety Recommendations* . . . . . iv

**CHAPTER 1: SCOPE** . . . . . **1-5**

    Section 1a: To the Installer . . . . . 1-5

    Section 1b: Objective. . . . . 1-5

**CHAPTER 2: GETTING STARTED** . . . . . **2-6**

    Section 2a: Mechanical Configurations . . . . . 2-6

    Section 2b: Electrical Standards . . . . . 2-6

    Section 2c: Installation Specifications . . . . . 2-6

    Section 2d: Base Unit Types . . . . . 2-6

    Section 2e: Header Types . . . . . 2-7

    Section 2f: How to Determine Handing . . . . . 2-7

    Section 2g: Swing Door Types . . . . . 2-8

    Section 2h: Control Types . . . . . 2-9

    Section 2i: Emergency Egress . . . . . 2-9

    Section 2j: Associated Manuals Part Number . . . . . 2-9

**CHAPTER 3: PREPARE THE ROUGH OPENING** . . . . . **3-10**

**CHAPTER 4: ASSEMBLE THE DOOR FRAME** . . . . . **4-11**

    Section 4a: Prep the Bottom Load Header . . . . . 4-11

    Section 4b: Prep the Jamb Tubes . . . . . 4-14

    Section 4c: Install the Header to Jamb Tubes . . . . . 4-15

**CHAPTER 5: INSTALL FRAME TO BUILDING** . . . . . **5-16**

    Section 5a: Secure Frame to Rough Opening . . . . . 5-16

    Section 5b: Install the Finger Guard . . . . . 5-17

**CHAPTER 6: INSTALL BOTTOM LOAD COMPONENTS..... 6-19**

- Section 6a: Secure Incoming Wires .....6-19
- Section 6b: Install Motor/Operator into Header.....6-19
- Section 6c: Install the Control.....6-20
- Section 6d: Install Optional Components .....6-21

**CHAPTER 7: 110 VAC GENERAL WIRING..... 7-22**

**CHAPTER 8: INSTALL THE FLOOR PIVOT..... 8-23**

**CHAPTER 9: INSTALL THE SADDLE THRESHOLD ..... 9-23**

**CHAPTER 10: INSTALL THE SWING DOOR..... 10-23**

- Section 10a: Install the NABCO Swing Door ..... 10-23
- Section 10b: Install the Swing Door (Not provided by NABCO)..... 10-24

**CHAPTER 11: INSTALL THE SWING ARM..... 11-31**

- Section 11a: Set Pre-Load ..... 11-31
- Section 11b: Secure the Swing Arm ..... 11-32
- Section 11c: Test the Pre-Load ..... 11-34

**CHAPTER 12: PRE-LOAD ADJUSTMENTS..... 12-35**

- Section 12a: Rotate the Cam for Back Check..... 12-35
- Section 12b: Adjust the Swing Arm for Latch Check..... 12-36

## WARNING LABELS

Warning labels are universal and used to alert an individual of potential harm to one's self or to others. The following warning labels are listed in a hierarchy order that defines the most potential danger first, and the least potential danger last. Please refer to this page in the event that a warning label is displayed within this manual and further definition needs to be explained.

**DANGER**

Indicates potentially dangerous situations. Danger is used when there is a hazardous situation where there is a *high* probability of severe injury or death. It should not be considered for property damage unless personal injury risk is present.

**WARNING**

Indicates a hazardous situation which has *some* probability of severe injury. It should not be considered for property damage unless personal injury risk is present.

**CAUTION**

Indicates a hazardous situation which *may result in a minor injury*. Caution should not be used when there is a possibility of serious injury. Caution should not be considered for property damage accidents unless a personal injury risk is present.

**Notice:** Indicates a statement of company policy as the message relates to the personal safety or protection of property. Notice should not be used when there is a hazardous situation or personal risk.

*Note:* Indicates important information that provides further instruction.

## GENERAL SAFETY RECOMMENDATIONS

### WARNING

Read this “General Safety Recommendations” section before installing, operating or servicing the automatic door. Failure to follow these practices may result in serious consequences.

**Notice:** Read, study and understand the operating instructions contained in, or referenced in this manual before operating. If you do not understand the instruction, ask the installing qualified technician to teach you how to use the door.

### DANGER

Do not place finger or uninsulated tools inside the electrical controller. Touching wires or other parts inside the enclosure may cause electrical shock, serious injury or death.

**Notice:** This manual and the owner’s manual must be given to and retained by the purchasing facility or end user.

**Notice:** Advise the purchasing facility or end user to make regular safety checks and all other duties that may apply.

- ▶ If the door appears broken or does not seem to work correctly, it should be immediately removed from service until repairs can be carried out or a qualified service technician is contacted for corrective action.
- ▶ Disconnect power at the fused disconnect during all electrical or mechanical service. When uncertain whether power supply is disconnected, always verify using a voltmeter.
- ▶ All electrical troubleshooting or service must be performed by qualified electrical technicians and must comply with all applicable governing agency codes.
- ▶ It is the responsibility of the installing window technician to install all warning and instructional labels in accordance with ANSI 156.10 (GT-300 and GT-8300) or ANSI 156.19 (GT-350 and GT-8350).
- ▶ It is the responsibility of the purchasing facility or end user to keep warning and instructional labels and literature legible, intact and with the door. Replacement labels and literature may be obtained from local NABCO Entrances, Inc. distributors. If the name of the local distributor is unknown, contact NABCO Entrances, Inc. at 1-877-622-2694 for assistance.
- ▶ Do Not take shortcuts.
- ▶ Study and understand both ANSI Standard Codes A156.10 and A156.19.
- ▶ Ensure that all safety devices provided by the manufacturer work as intended.
- ▶ Ensure that all safety decals are properly displayed on any/all swing doors.

## CHAPTER 1: SCOPE

### Section 1a: To the Installer

The purpose of this manual is to familiarize the installer and purchaser with the proper installation and operation of this system. It is essential that this equipment be properly installed and operational before the door is used by the public. It is the installer's responsibility to inspect the operation of the entrance system to be sure it complies with any applicable standards. In the United States, ANSI Standard 156.10 (GT-300 and GT-8300) or ANSI Standard 156.19 (GT-350 and GT-8350) covers these types of doors. Other local standards or codes may apply. Use them in addition to the ANSI standard. The GT-300, GT-8300, GT-350 and GT-8350 OHC are listed with the Underwriters Laboratory and is identified as such on the label.

Instruct the building owners and operator on the essentials of the operation of the door and this device. The owner should follow these instructions to determine whether the door is operating properly and should immediately call for service if there is any malfunction. All installation changes and adjustments must be made by qualified, NABCO trained technicians.

The OHC Header assembly can be purchased as a standalone unit and may be installed on other makes of doors and frames in lieu of the NABCO Complete Swing Door System.

### Section 1b: Objective

The GT-300, GT-8300, GT-350 and GT-8350 OHC swing door series is designed inline with the frame as a concealed unit. The door function is operated by the Magnum IV Control Board which offers many features to accommodate most installation options. This manual offers step by step instructions to install each of the GT-300, GT-8300, GT-350 and GT-8350 OHC swing door units.

## CHAPTER 2: GETTING STARTED

### Section 2a: Mechanical Configurations

Base Model	OHC Bottom Load	OHC Side Load
Full Automatic	GT300	GT8300
Low Energy	GT350	GT8350

### Section 2b: Electrical Standards

*Note:* It is recommended for the Installer to use an Electrical Conduit to house all incoming 120 VAC wires.

*Note:* All wiring must conform to standard wiring practices and be in accordance with national and local electrical codes.

Electricity	Description
Power Input	120 ( $\pm 10\%$ ) AC 50-60Hz, 10 Amps
Available Current for accessories	0.5 Amps 24 VAC
Available wire size for incoming power	14 AWG

### Section 2c: Installation Specifications

Specification	Measurement	
Minimum Frame Face for Mounting	1-3/4 inches (44mm)	
Minimum Clearance from Top of Door to Ceiling	Bottom Load	Side Load
	6-1/8" (156 mm)	7-18" (181 mm)
Minimum Door Thickness	1-3/4 inches (44 mm)	
Door Width	Specified when ordered	

### Section 2d: Base Unit Types

#### 2.d.a: Full Power Swing Doors

- ▶ Utilize Sensor(s) to open a Swing door.
  - Sensors activate the Control by detecting motion of pedestrians (or moving objects) that come into range.
- ▶ Must be compliant with ANSI Standard Code 156.10 to reduce chance of injury to pedestrians and wheeled traffic.

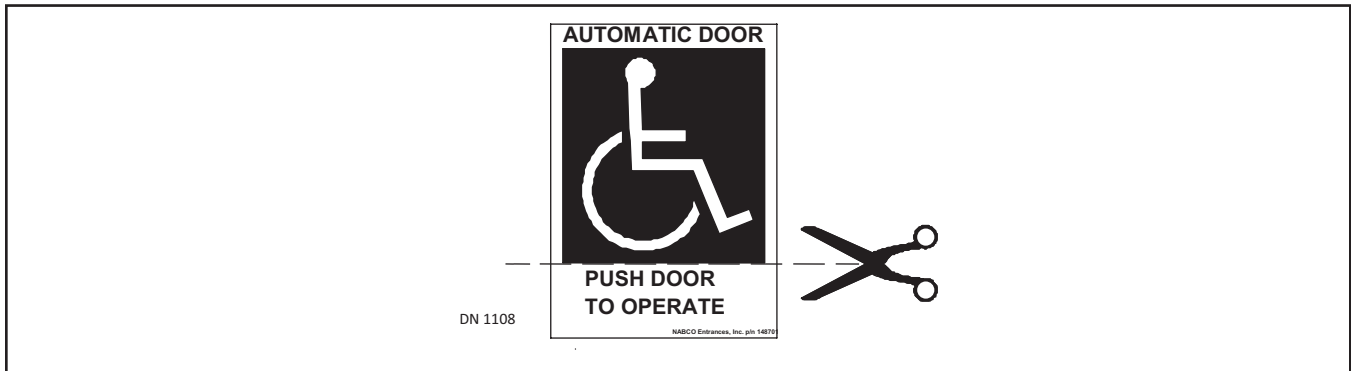
#### 2.d.b: Low Energy Swing Doors

- ▶ Utilize a Knowing Act to open a Swing door.
  - A conscious effort that is carried out in many different ways, including (but not limited to): manually opening/closing a Swing door; pressing various types of Push Plates; turning a Key switch; flipping a Rocker Switch; utilizing a keypad or card reader, etc.
- ▶ Must be compliant with the ANSI Standard Code 156.19 to reduce chance of injury to pedestrians and wheeled traffic.



**DANGER**

Always remove the bottom portion of the HandiCap Label stating "Push Door To Operate" if the "Push-n-Go" feature is not being used.



**Section 2e: Header Types**

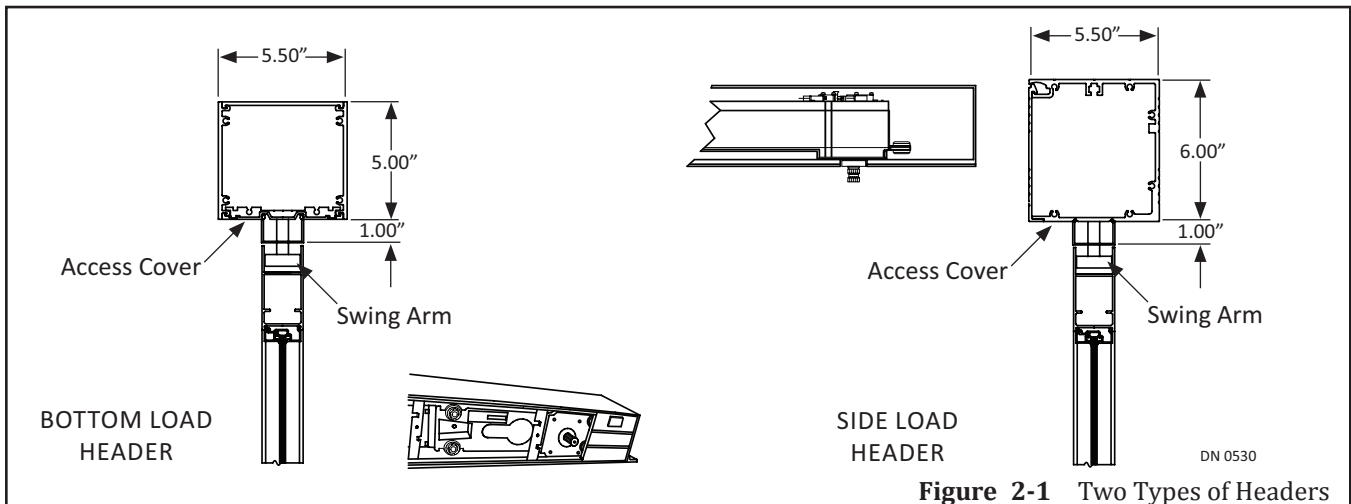


Figure 2-1 Two Types of Headers

**Section 2f: How to Determine Handing**

- ▶ To Determine Handing from the Operator: locate the Serial Number underneath Operator. Please see Figure 2-2.
  - The Letter (L) or (R) located in front of the Serial Number indicates the Handing.

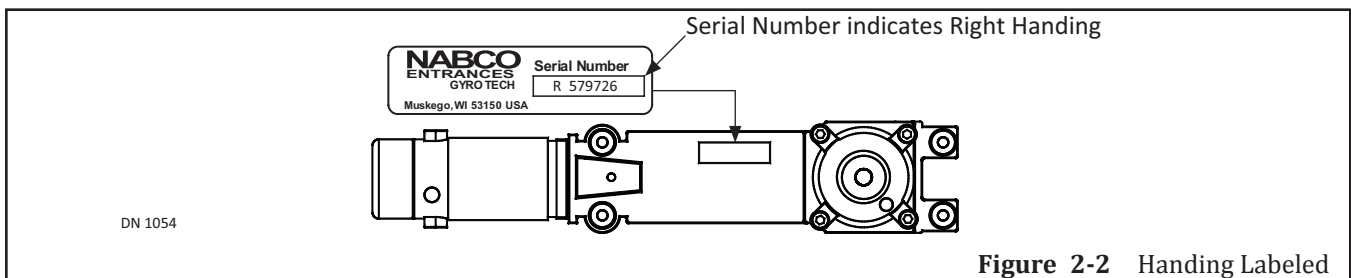
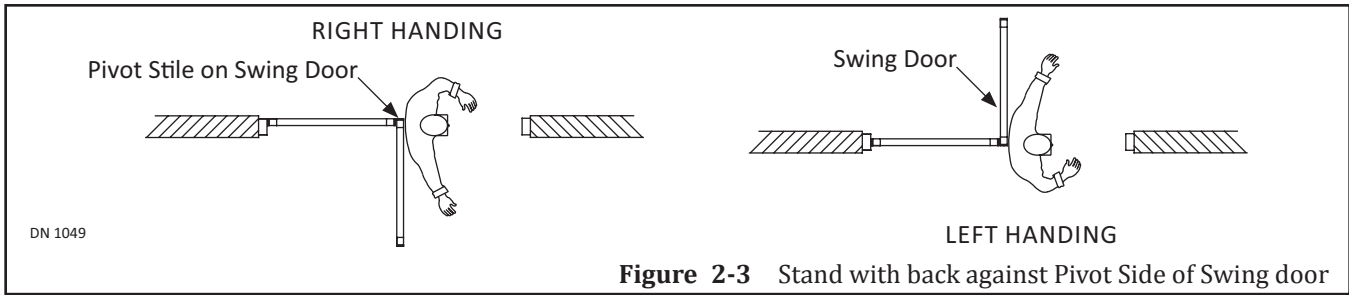


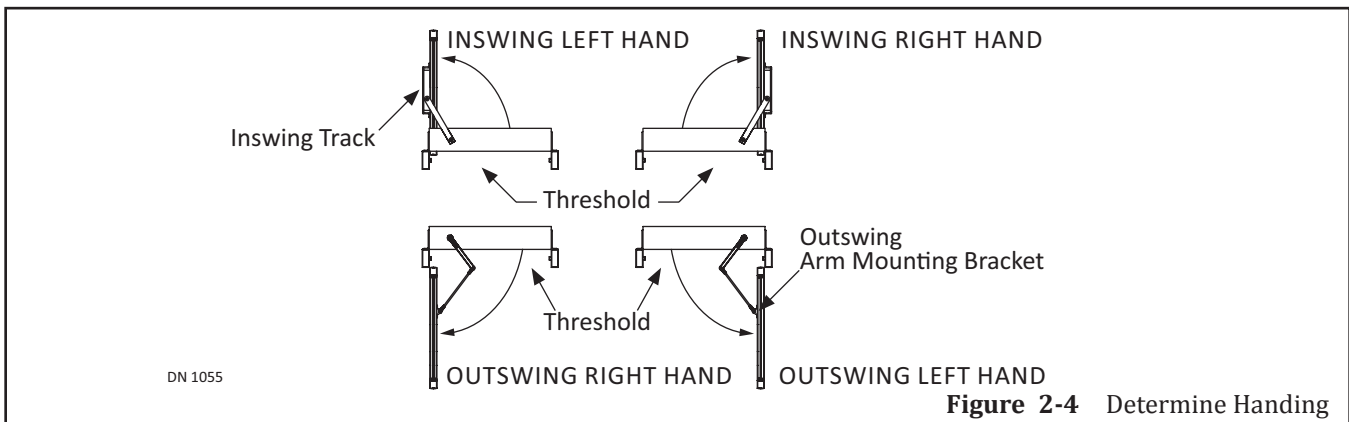
Figure 2-2 Handing Labeled

- ▶ To determine Handing from standing underneath the Header: Open the Swing door. Butt your back against the Pivot side of Swing door. Swing out the (right or left) arm in the direction the Swing door opened. Please see Figure 2-3.



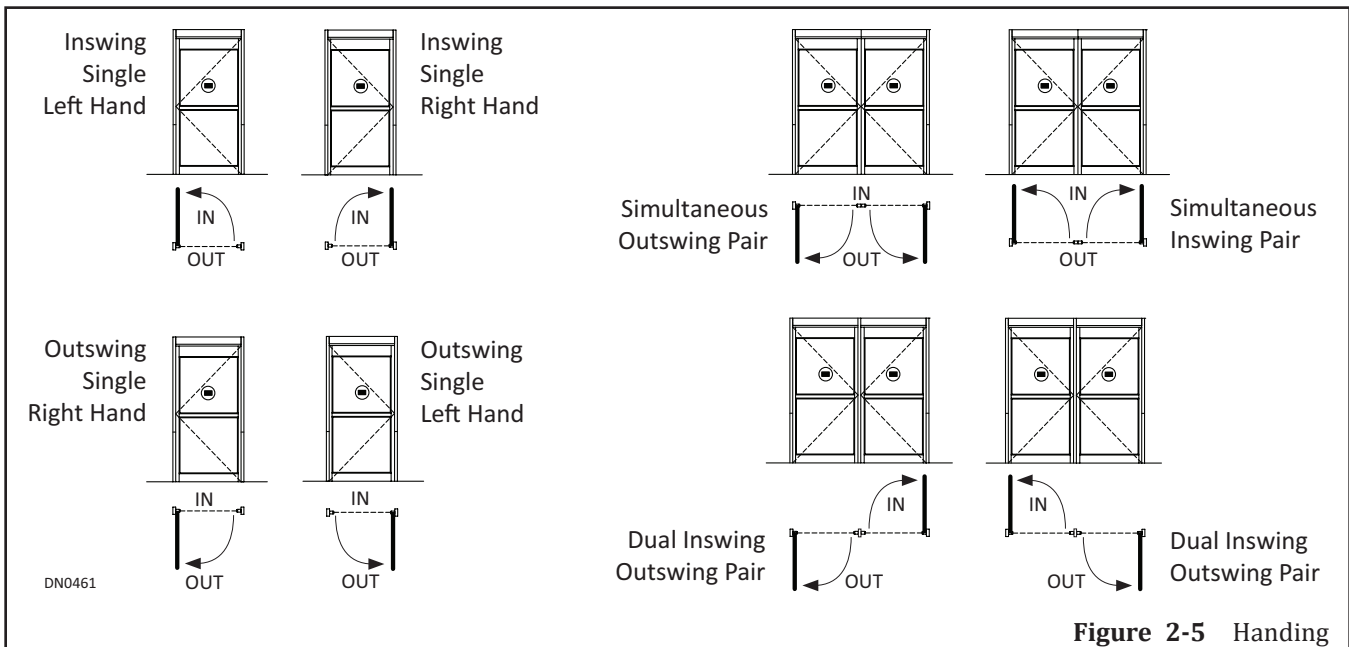
**Figure 2-3** Stand with back against Pivot Side of Swing door

- ▶ To determine Handing from the direction the Swing Arm opens. Please see Figure 2-4.
  - If the Swing Arm swings underneath the Threshold to open, it is an Outswing Unit.
  - If the Swing Arm does not swing underneath the Threshold to open, it is an Inswing Unit.



**Figure 2-4** Determine Handing

### Section 2g: Swing Door Types



**Figure 2-5** Handing

## Section 2h: Control Types

The Control is programmed to open/close the Swing door according to how the door will be used in terms of Handing, Speed, Time Delay, Back Check, and Latch Check. Two types of Controls can be purchased for the CU Series Swing doors:

- ▶ Magnum 4A
- ▶ Analog Control

## Section 2i: Emergency Egress

Emergency Egress allows a Swing door to breakout during an emergency, and is commonly referred to as a Panic Breakout. The hardware used to allow Emergency Egress is called a Panic Latch. A Panic Latch can only be installed on Inswing Doors.

## Section 2j: Associated Manuals Part Number

- ▶ Magnum 4A Control Wiring and Adjustment Manual; P/N 15-10682
- ▶ Analog Control Wiring and Adjustment Manual; P/N 15-10745
- ▶ GT300/350/8300/8350 OHC Swing Door QSPG; P/N 15-12499-005

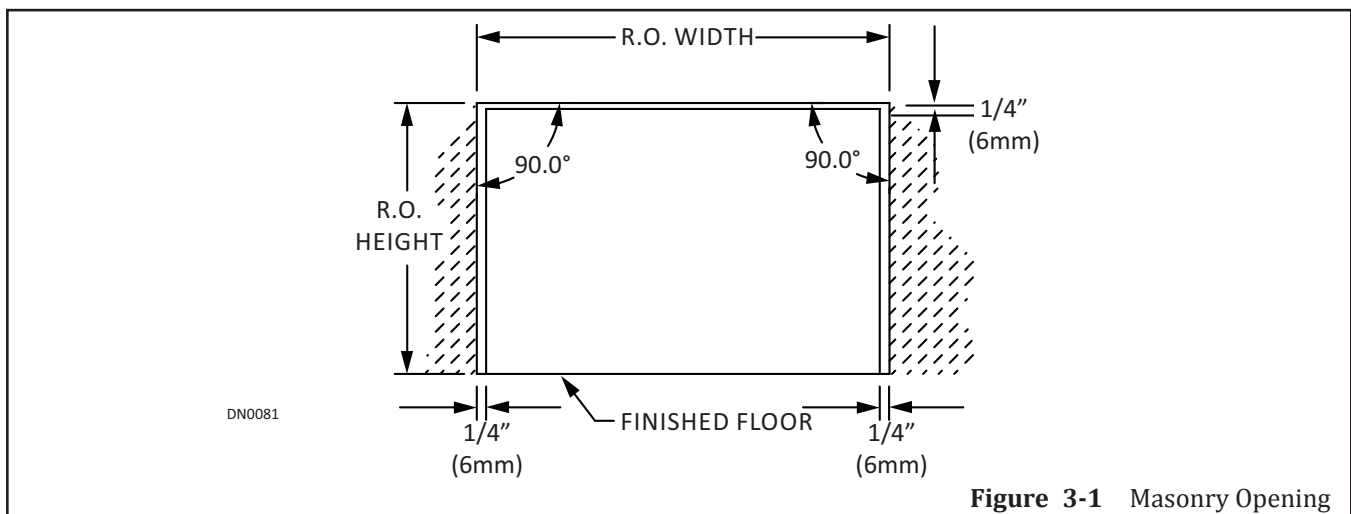
## CHAPTER 3: PREPARE THE ROUGH OPENING

*Note:* Make allowances for tile or other existing materials that may change the floor height.

*Note:* Use of a supplemental door stop is always required.

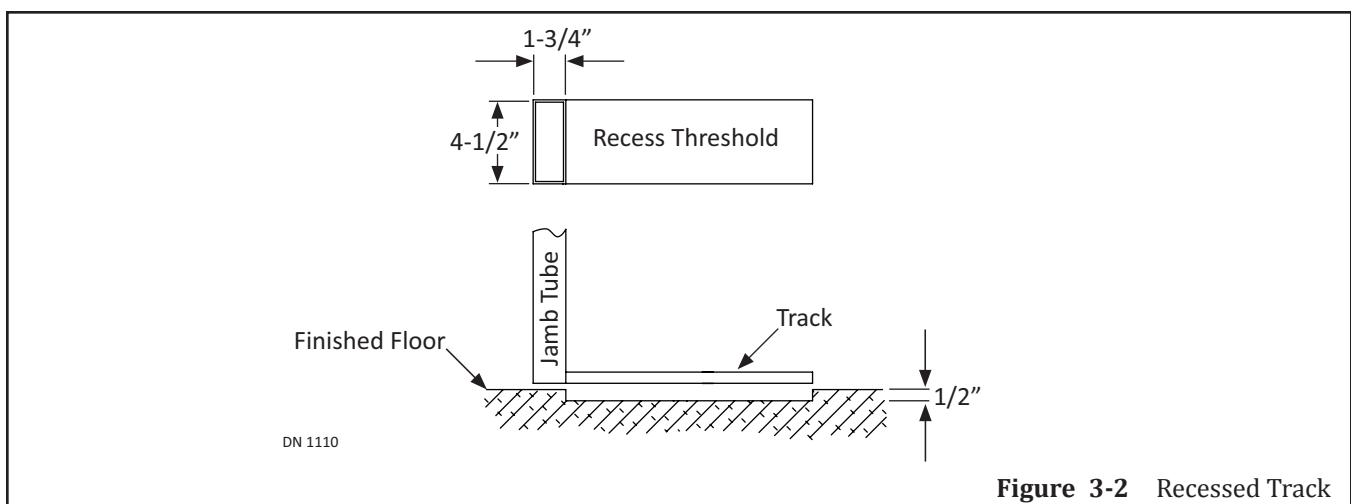
1. Ensure the Rough Opening is the correct size. Please see Figure 3-1.

- ▶ The width of the Rough Opening should equal:  
**PACKAGE WIDTH + 1/4 INCH ON EACH SIDE**
- ▶ The height of the Rough Opening should equal:  
**PACKAGE HEIGHT + 1/4 INCH**



**Figure 3-1** Masonry Opening

2. Check to make sure that the floor is level across the entire opening.
3. If used, check recessed threshold across the door opening. Please see Figure 3-2.



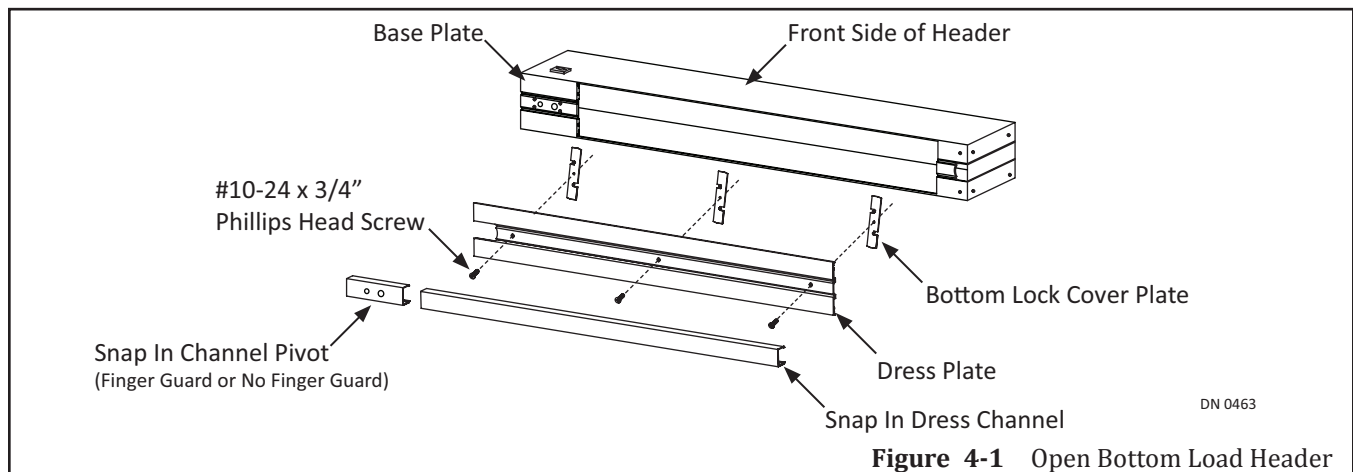
**Figure 3-2** Recessed Track

## CHAPTER 4: ASSEMBLE THE DOOR FRAME

### Section 4a: Prep the Bottom Load Header

***FOR SIDE LOAD HEADER SKIP TO  
SECTION 4B***

1. Place Header on flat surface with Bottom facing up.
  - a. Protect header from scratches.
2. Remove the Snap In Dress Channel and the Snap In Channel Pivot. Please see Figure 4-1.
3. Remove screws used to secure the Snap In Dress Plate. Set aside.
4. Remove the Snap In Dress Plate and (3) Bottom Cover Lock Plates. Set Aside.
5. Remove any/all decals, paperwork and Parts bag from inside Header. Set all Contents aside.

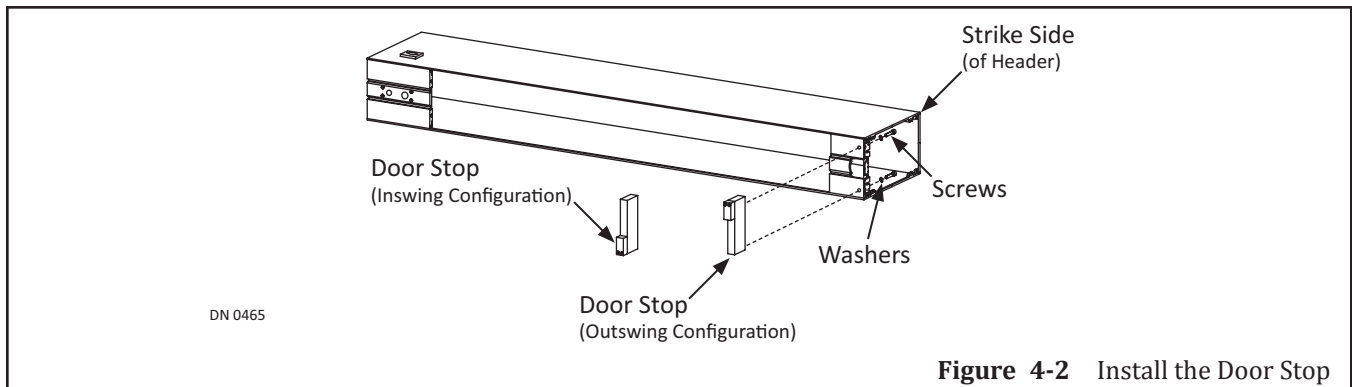


#### 4.a.a: Install the Door Stop (Standard)

***FOR PANIC LATCH SKIP TO  
SUBSECTION 4.A.B***

Door Stops are standard and can be installed on an Inswing door and an Outswing door. A Door Stop is used to stop the door from swinging farther back from the fully closed position.

1. Obtain the Door Stop.
2. Remove (4) Socket Head Cap Screws and (4) Washers. Set aside.
3. Go to the bottom, Pivot side of Header. Butt the Door Stop against the underside of the 3-1/4 inch Strike Base. Please see Figure 4-2.
  - a. For an Outswing, the Stop end of Door Stop must face front side of Header.
  - b. For an Inswing, the Stop end of Door Stop must face back side of Header.
4. Secure Door Stop from inside Header with (2) Socket Head Cap Screws and (2) Washers.

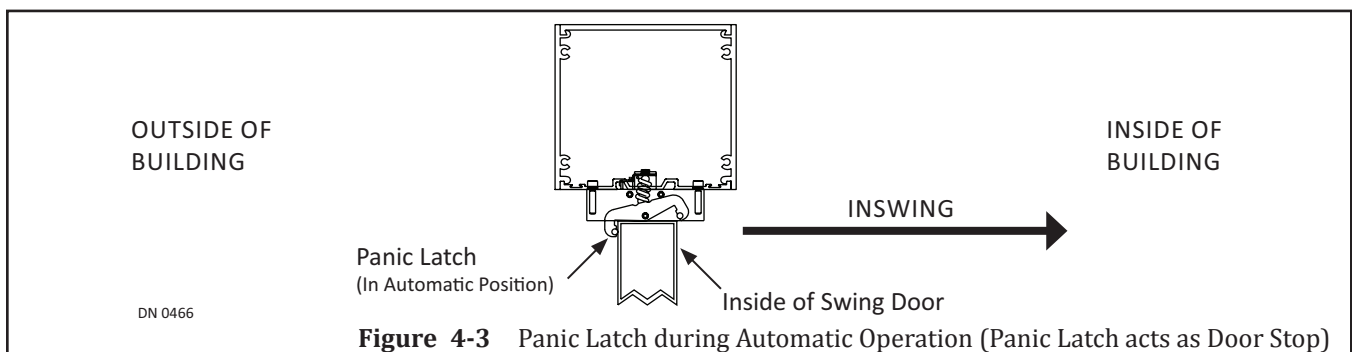


**Figure 4-2** Install the Door Stop

**4.a.b: Install the Panic Latch (Inswing Doors)**

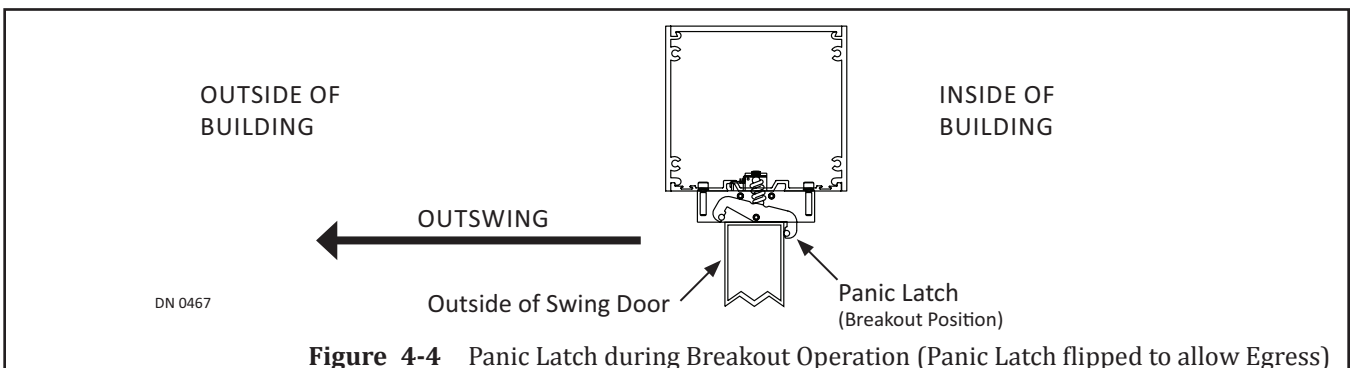
*Note: The Panic Latch is installed on Inswing doors only.*

During Automatic Operation, the Inswing door opens to the Interior side of the building/room. The Panic Latch is then used as a Door Stop. Please see Figure 4-3.



**Figure 4-3** Panic Latch during Automatic Operation (Panic Latch acts as Door Stop)

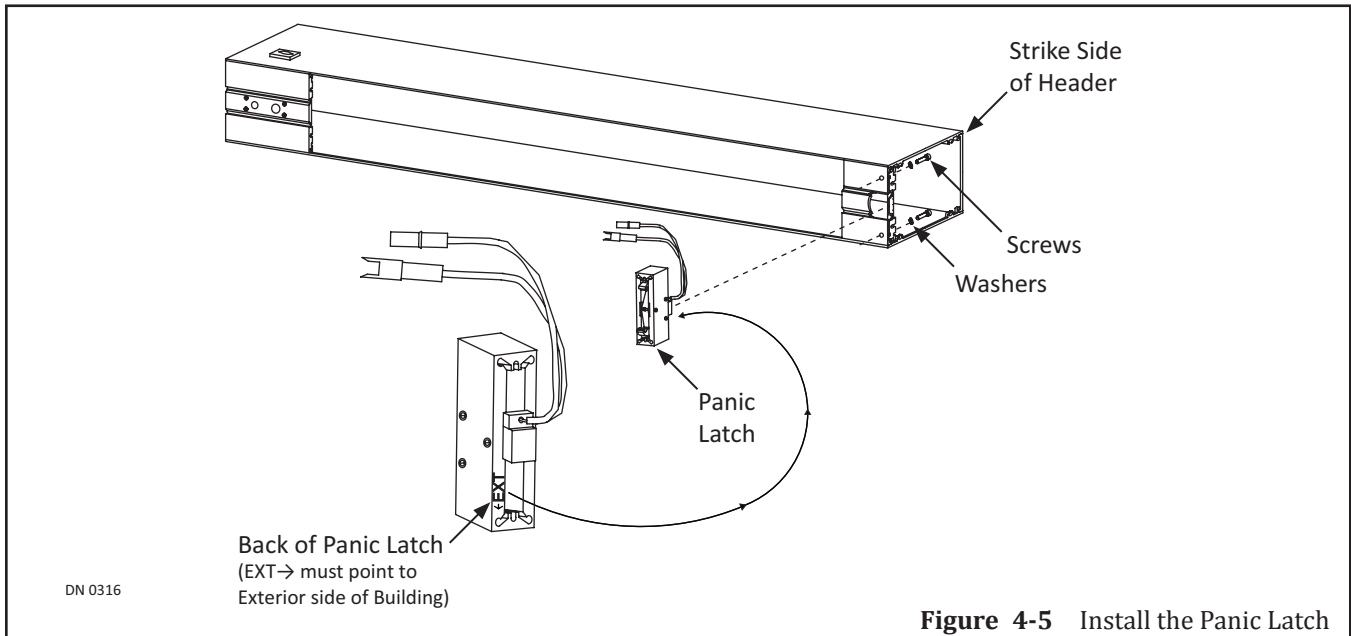
During Emergency Operation, the Inswing door is manually pushed Out to the exterior side of the building/room (not to exceed 50 pounds of pressure; per ANSI code). The Panic Latch flips to allow emergency egress and immediately shuts the Swing door OFF. Please see Figure 4-4.



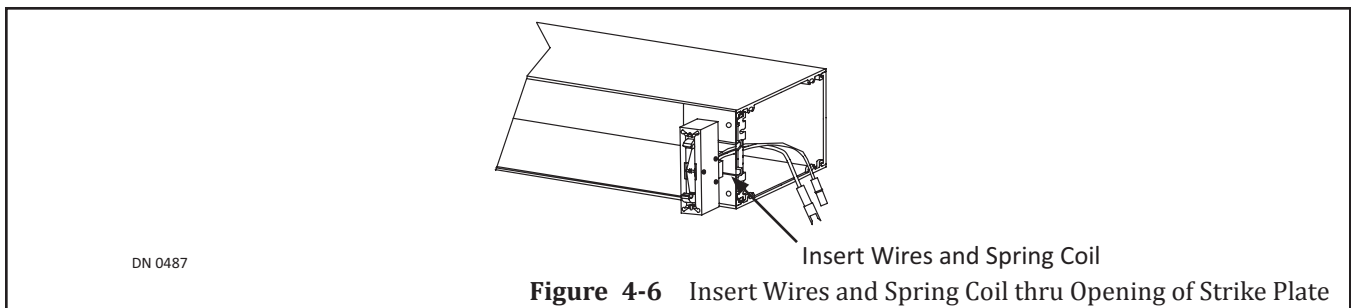
**Figure 4-4** Panic Latch during Breakout Operation (Panic Latch flipped to allow Egress)

*Note: For wiring instructions please refer to P/N 15-4572 Panic Breakout Latch Wiring Installation Instructions Manual.*

1. Obtain the Panic Latch and (1) Decal. Set the Decal aside with all other Decals that were packed within Header.
  - a. Decals are placed on Swing Door(s) after installation is complete.
2. Remove (4) Socket Head Cap Screws and (4) Washers. Set aside.
3. Turn the Panic Latch so the (EXT→) (exit arrow) points to the Exterior side of the Building. Please see Figure 4-5.
  - a. Failure to do so, will install the Panic Latch backwards.



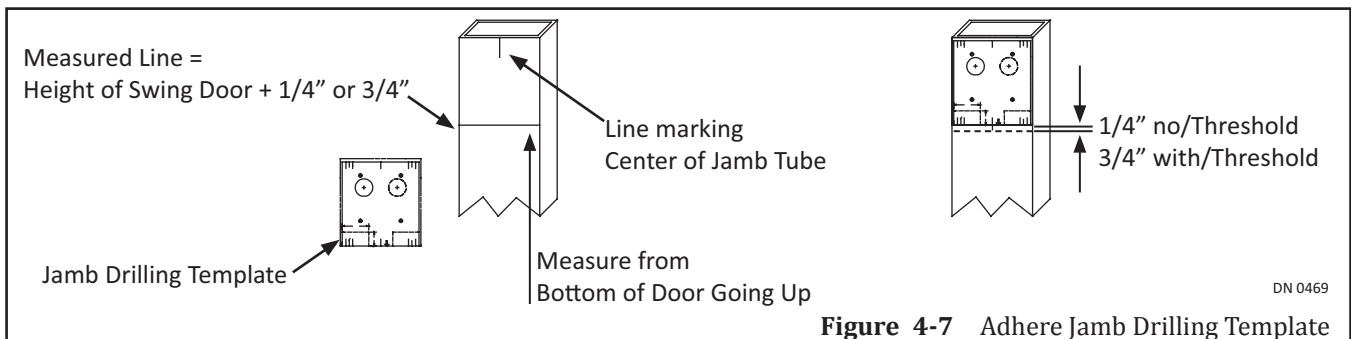
4. Go to the bottom, Strike side of Header.
5. Insert the Panic Latch wires and spring coil into the opening until the Panic Latch butts up against the Header. Please see Figure 4-6.



6. Secure the Panic Latch from inside the Header with (2) Socket Head Cap Screws and (2) Washers.
  - a. Do Not wire or test the Panic Latch at this time.

## Section 4b: Prep the Jamb Tubes

1. Measure the full height of existing Swing door.
2. Go to the bottom of each Jamb Tube, measure the full height calculation of Swing door plus:
  - ▶ 3/4 inch (19mm); if a Threshold is being installed
  - ▶ 1/4 inch (6.4mm); if a Threshold is not being installed
3. Mark the measurement across the full width of each Jamb Tube.
  - a. It is recommended to use a level for this step.
4. Obtain (1) Jamb Drilling Template provided by NABCO.
5. Locate the line that was drawn across the inside face of each Jamb Tube. Place the bottom edge of the Jamb Drilling Template directly above that line.
6. Line up center of the Jamb Drilling Template to the previously drawn center mark.
7. Adhere the Jamb Drilling Template to each Jamb. Please see Figure 4-7.
  - a. The Jamb Drilling Template is removable.
  - b. An arrow is clearly marked at the bottom of the Jamb Drilling Template. This arrow must point to the line that was marked across the full width of Jamb.

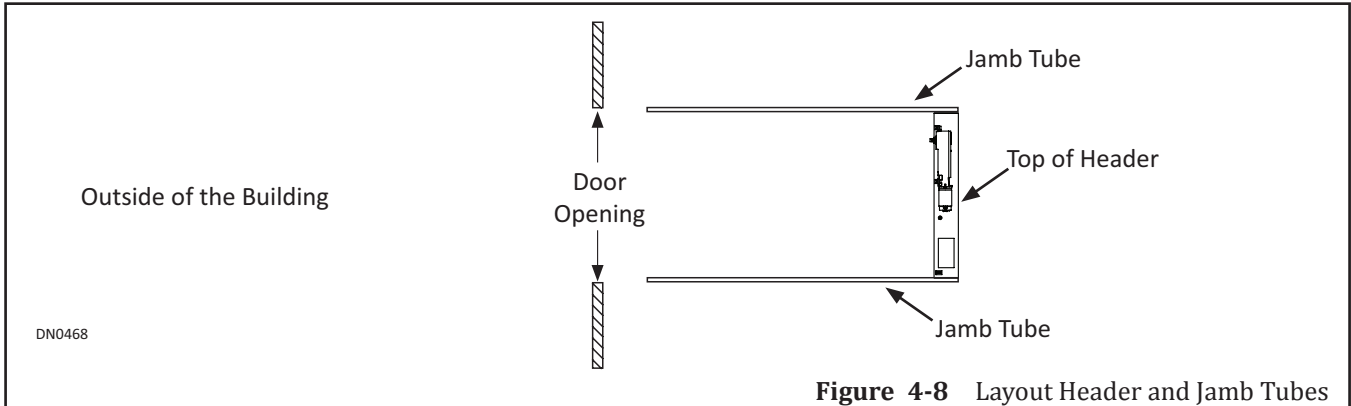


8. Drill (4) .391 diameter holes through (4) clearly marked (A)s on the Template. Countersink each screw hole. Please see Figure 4-8.
  - a. It is recommended to drill tap threads for anchors in a steel or aluminum structure.
9. Obtain (4) Rivnuts provided by NABCO. Install (1) Rivnut into each drilled .391 hole.
10. Drill (1) 1-1/4 inch diameter hole through (1 of 2) clearly marked (B)s on the Template to allow incoming 120 VAC Power.
  - a. The 120 VAC incoming power must be routed through the Strike Jamb, only.
11. Remove the Template from the Strike Jamb, then adhere same Template to the Pivot Jamb.
12. Repeat steps.
13. Remove the Template. Set aside.

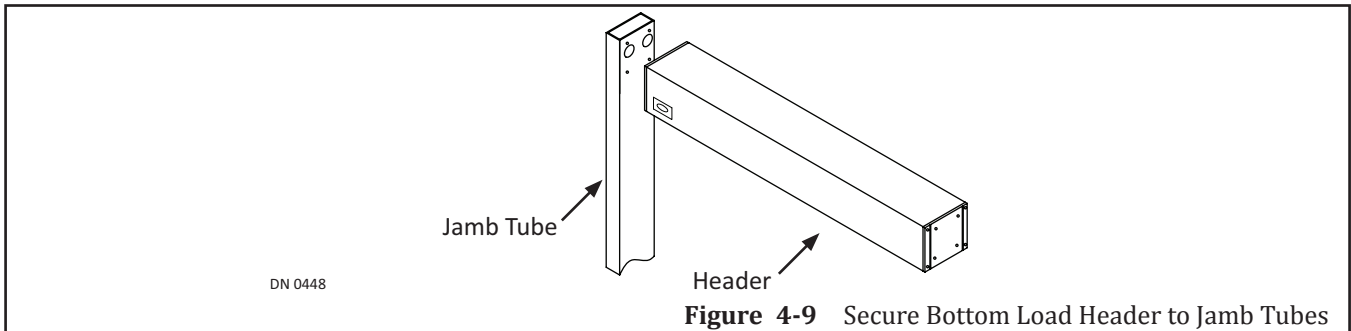


### Section 4c: Install the Header to Jamb Tubes

1. Determine which Jamb tube is the Pivot Jamb and the Strike Jamb.
  - a. Swing door pivots on side of Pivot Jamb.
  - b. Swing door locks on side of Strike Jamb.
2. Position each Jamb tube at both sides of the Header. Please see Figure 4-8.
  - a. Be sure to orientate the frame in relation to the outside of building/room.



3. Secure Header to both Jamb Tubes with (8) 1/4-20 x 3/4 inch Hex Head Cap Screws and (8) 1/4 inch Star Washers from the Parts bag provided within the Header. Please see Figure 4-9.



## CHAPTER 5: INSTALL FRAME TO BUILDING

### Section 5a: Secure Frame to Rough Opening

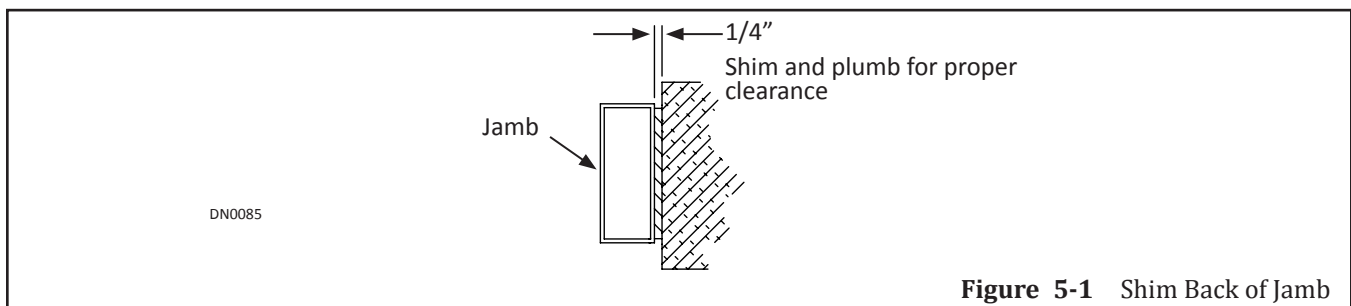
1. Lift to position the assembled Frame into the rough opening.
2. Insert all incoming wiring through the 1-1/4 inch hole located on the Strike side of Header.

*Note:* It is recommended for the Installer to use an Electrical Conduit to house all incoming 120 VAC wires.

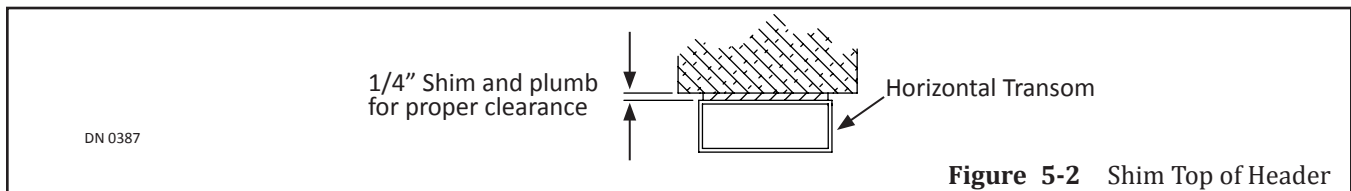
*Note:* Incoming 120 VAC Power wires must be pulled through the Strike end of Header for a single Swing door or the middle of Header for a simultaneous pair Swing door.

*Note:* All wiring must conform to standard wiring practices and be in accordance with national and local electrical codes.

3. Plumb Jamb tubes in both planes to ensure the rough opening allows a 1/4 inch clearance. Please see Figure 5-1.
  - a. Shim back of jamb as required.



4. Plumb the Header at the top to ensure the rough opening allows a 1/4 inch clearance. Please see Figure 5-2.
  - a. Shim top of Header as required.



*Note:* It is recommended to countersink holes as required to flush the surface.

*Note:* It is recommended to drill tap threads for anchors in a steel or aluminum structure.

*Note:* If anchor points in structure are known, the aluminum door framing can be pre drilled prior to installing into the opening.

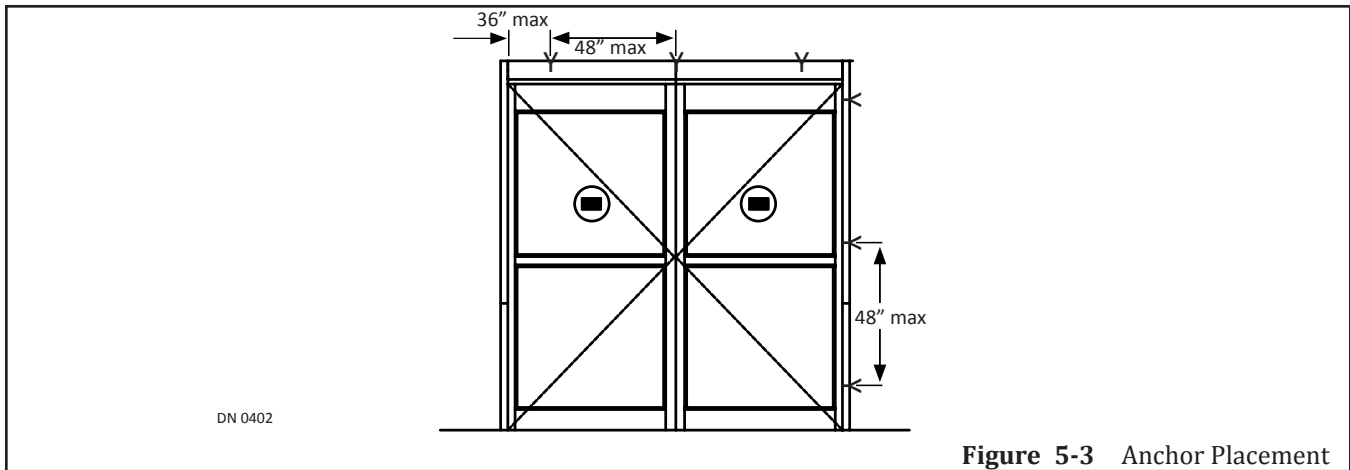
*Note:* To prevent Header sag, secure the Header in the middle to the top horizontal structural member of the opening. Use of 3/8 inch threaded rod or 1/4 inch bolts are acceptable methods of supporting the center of the header.

**5.a.a: Anchor Placement for Header**

Use 1/4 inch diameter anchors or 3/8 inch threaded rods, with a maximum 48 inches on center. First anchor maximum is 36 inches from each end of the Header. Anchors and Fasteners must be appropriate for the type of structure being fastened into. Anchors and Fasteners are not provided by NABCO. Please see Figure 5-3 and Figure 5-4.

**5.a.b: Anchor Placement for Jamb Tubes**

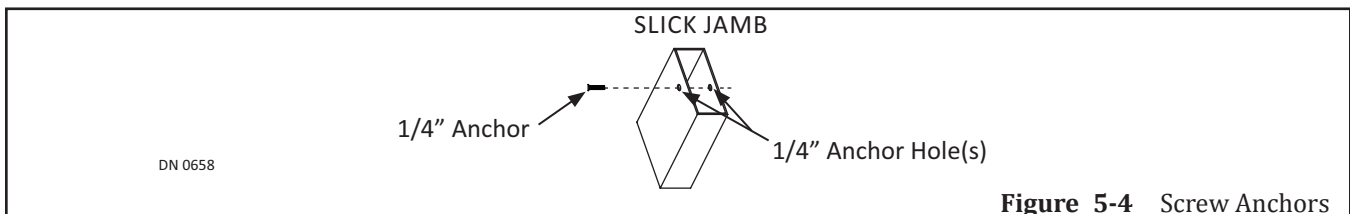
Use 1/4 inch diameter anchors with a minimum of 3 per Jamb Tube, maximum is 48 inches on center. Drill 1/4 inch diameter holes in the face of Jamb and then countersink each hole. Anchors and Fasteners must be appropriate for the type of structure being fastened into. Anchors and Fasteners are not provided by NABCO. Please see Figure 5-3 and Figure 5-4.

**Figure 5-3** Anchor Placement

5. Screw in fasteners to secure the Frame.

*Note:* Do not overtighten anchors to prevent deforming Jamb tubes.

*Note:* Ensure anchor heads to not come in contact with edges of glass to prevent breakage.

**Figure 5-4** Screw Anchors**Section 5b: Install the Finger Guard**

*Note:* Screws must be appropriate for the type of structure being fastened into.

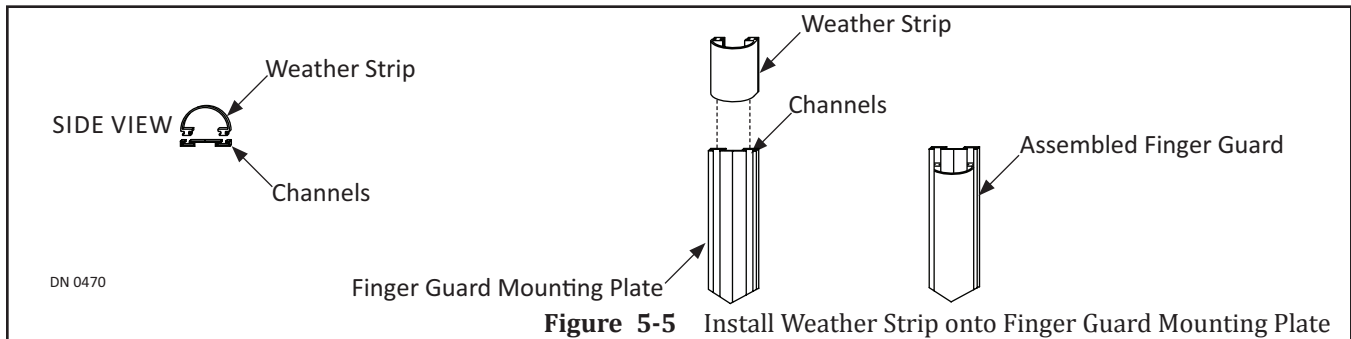
*Note:* Screws are not provided by NABCO.

*Note:* Do not overtighten screws to prevent deforming Weatherstrip Extrusion.

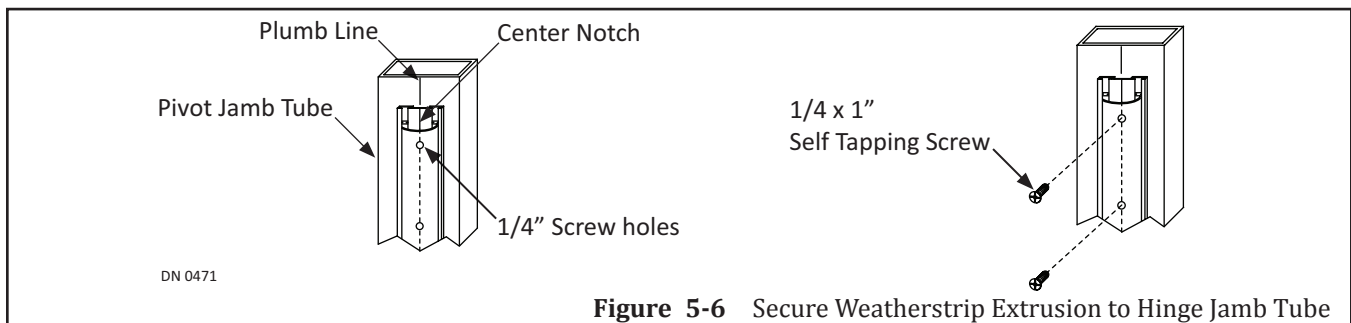
*Note:* Ensure each screw is flush to the Jamb tube.

1. Go to the top of the Pivot Jamb tube, at the center, drop a Plumb Line to the floor.
2. Mark the Center line on the inside face of the Pivot Jamb Tube.
  - a. It is recommended to use a level.

1. Obtain the Finger Guard Mounting Plate.
2. Insert the Weather Strip into both channels located on the Finger Guard Mounting Plate. Please see Figure 5-5.
  - a. Sprayed silicone (not included) inside the Channels may ease the insertion of the Weather Strip.



3. Line up the Center Notch located down the full length of the Finger Guard Mounting Plate, with the Center Mark located on the Pivot Jamb Tube. Please see Figure 5-6.
  - a. It is recommended to use a level.

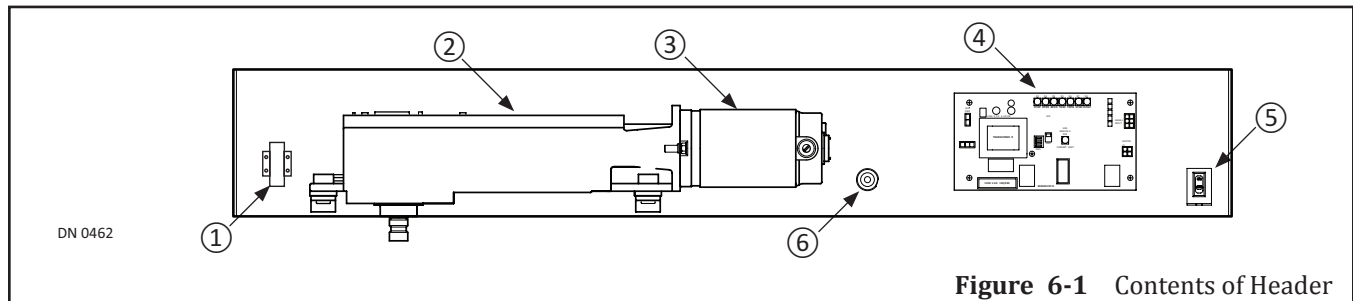


4. Drill (3-4) 1/4 inch evenly spaced screw holes down the Finger Guard Assembly.
  - a. Each screw hole must go through the Weather Strip, Mounting Plate and the Pivot Jamb Tube.
5. Secure the Finger Guard Mounting Plate onto the Pivot Jamb with 1/4 x 1 inch self tapping Screws (zinc or steel plated).

## CHAPTER 6: INSTALL BOTTOM LOAD COMPONENTS

### FOR SIDE LOAD HEADER SKIP TO CHAPTER 7

*Note: Location of Contents within Header are subject to change according to Swing door specifications.*

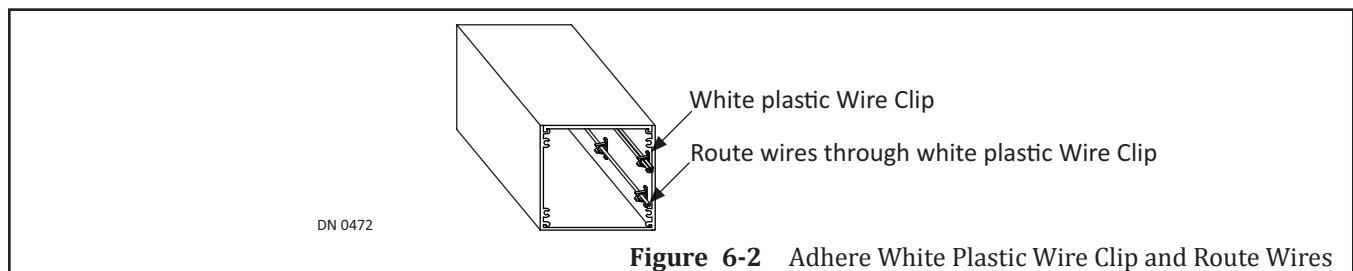


**Figure 6-1** Contents of Header

- |                           |                            |
|---------------------------|----------------------------|
| 1. Transformer (Optional) | 4. Rocker Switch           |
| 2. Motor Operator         | 5. Multi-Module (Optional) |
| 3. Control                | 6. Ground Screw            |

### Section 6a: Secure Incoming Wires

1. Obtain (self sticking) white plastic Wire Clips provided by NABCO.
2. Adhere each Wire Clip to sides of Header. Insert wiring (as deemed necessary). Please see Figure 6-2
  - a. 120 VAC Power wires must be routed separate from other wiring, adhere those Wire Clips inside the Header, near the top to prevent pinching.



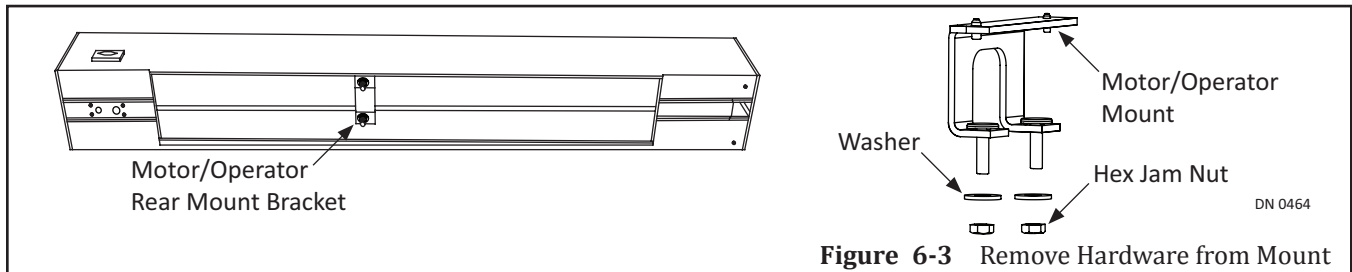
**Figure 6-2** Adhere White Plastic Wire Clip and Route Wires

*Note: If 120 VAC Power wires must be installed from Hinge Side of Header, ensure that wires are securely clipped, to prevent pinching of the wires during the Motor/Operator installation process.*

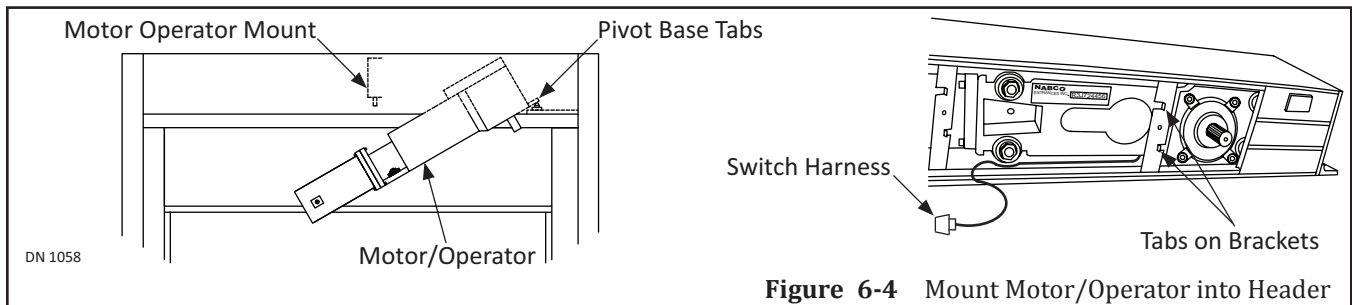
### Section 6b: Install Motor/Operator into Header

1. Go to (inside) top of Header. Please see Figure 6-3.
2. Locate factory installed, Rear Mount Bracket located inside Header.
3. With a 9/16 inch Deep Well Socket and Ratchet, remove (2) 3/8-16 Hex Jam Nuts and (2) Washers from (2) studs that extend downward from the Rear Mount Bracket.
  - a. Save all hardware for reinstallation.

4. Hold the Front end of Motor/Operator at an upward angle to slide Front Mount onto (2) Pivot Base Tabs located inside of Header.



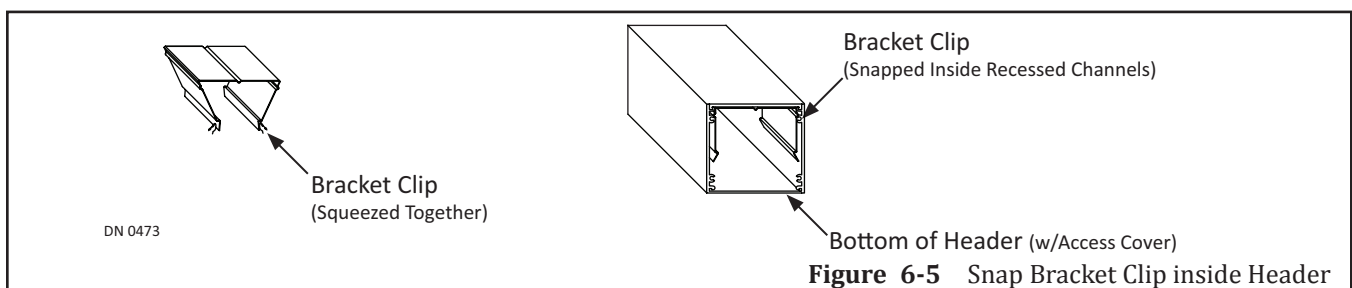
5. Lift the rear of the Motor Operator up onto (2) studs extending downward. Please see Figure 6-4.
  - a. Ensure the Switch Harness is tucked between the back wall of Header and above the Mounting Bracket.
6. Secure the Motor/Operator with (2) 3/8-16 inch Hex Jam Nuts and (2) 7/16 x 1 inch Washers.
  - a. It is important not to pinch any wiring during the Motor/Operator installation.



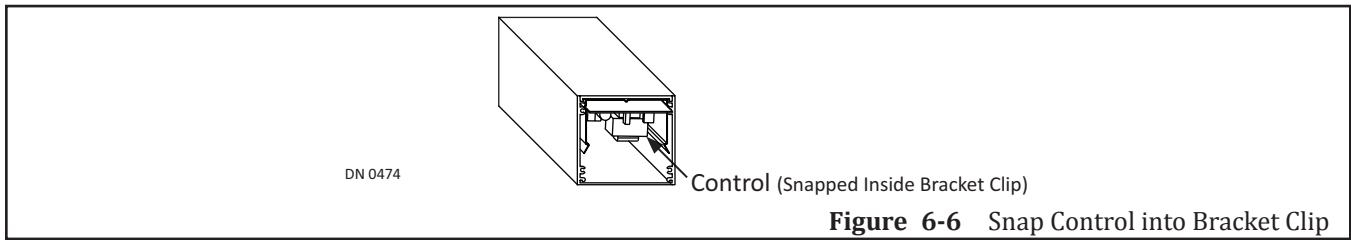
### Section 6c: Install the Control

It may be necessary to mount a Soft Starter Capacitor on the Operator prior to installing the Analog Control. For detailed information, please refer to the “Analog Control Wiring and Adjustment Manual; P/N 15-10745”.

1. Obtain the Bracket Clip.
2. Squeeze (2) open ends of the Bracket Clip together until both protruding channels are successfully snapped inside each recessed channel. Please see Figure 6-5.
3. Snap the Bracket Clip within the recessed channels approximately 4-5 inches away from where the Motor/Operator will be installed.



- 4. Snap the Control inside the Bracket Clip. Please see Figure 6-6.
  - a. Face of Control must face down (towards bottom opening of Header).

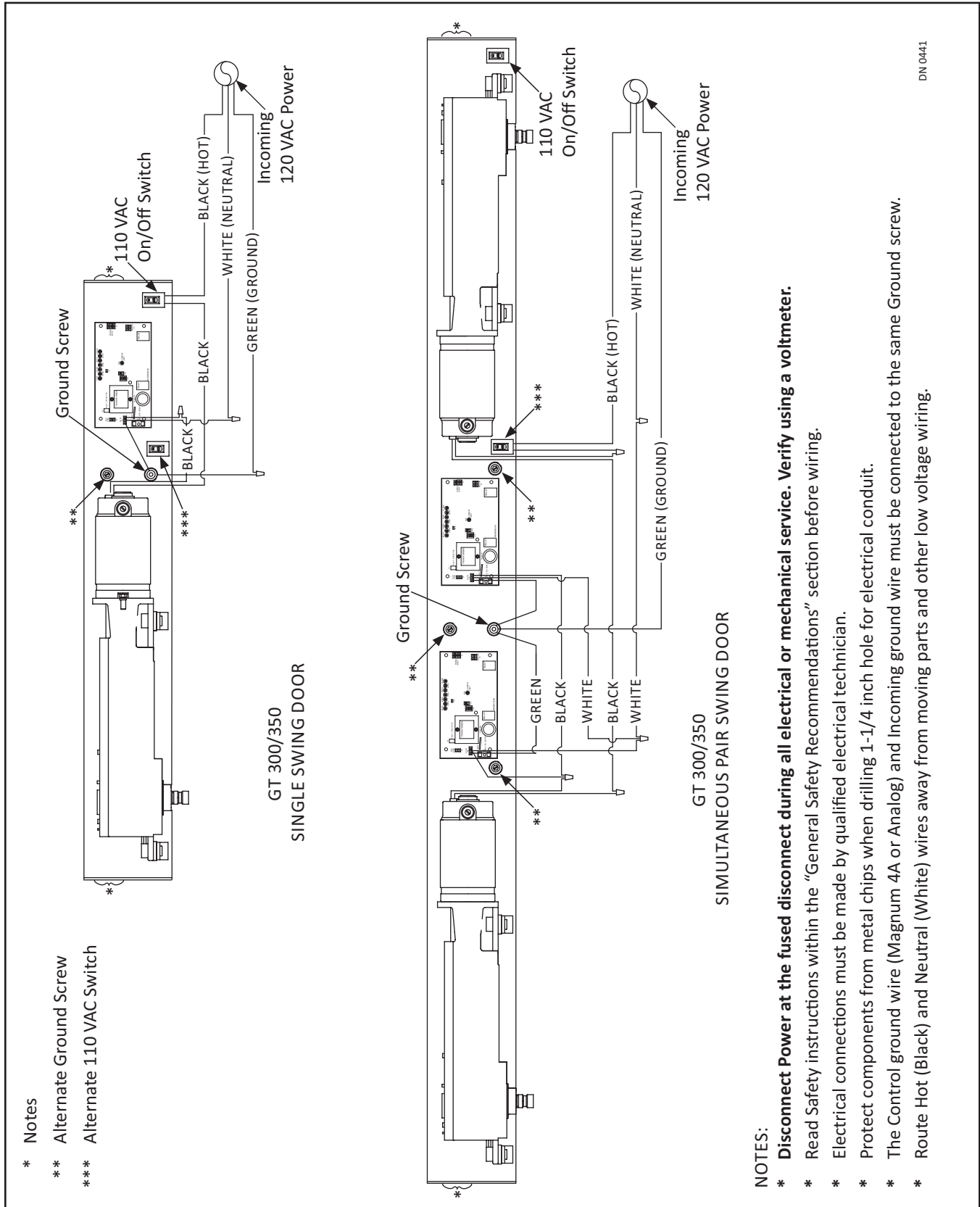


**Figure 6-6** Snap Control into Bracket Clip

### Section 6d: Install Optional Components

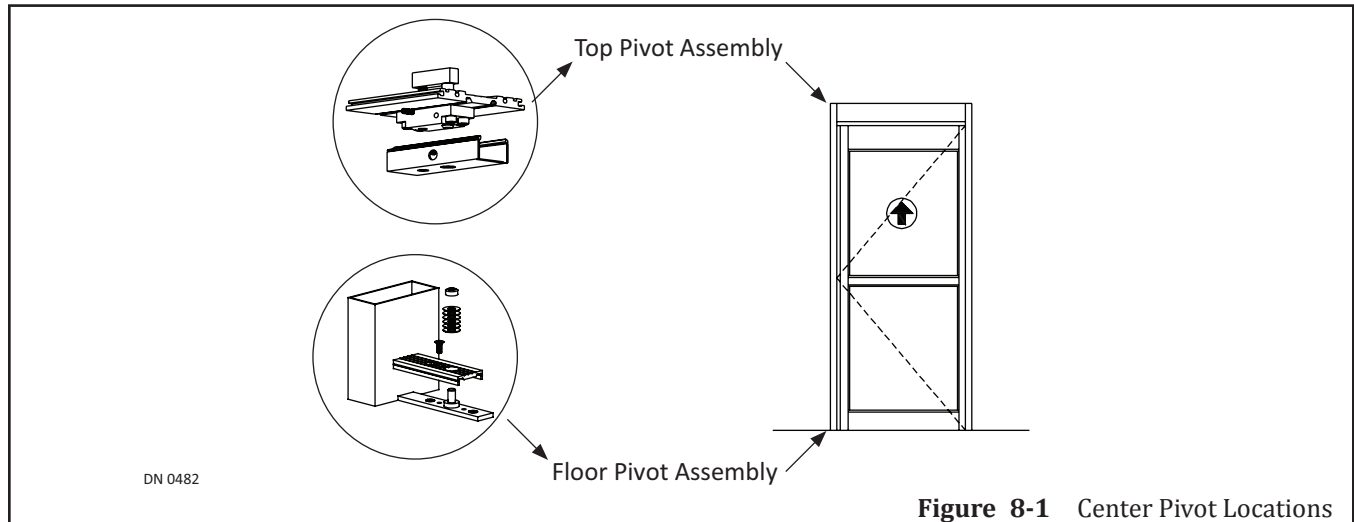
Install all other optional components by following installation and wiring instructions that were provided with each Component.

## CHAPTER 7: 110 VAC GENERAL WIRING



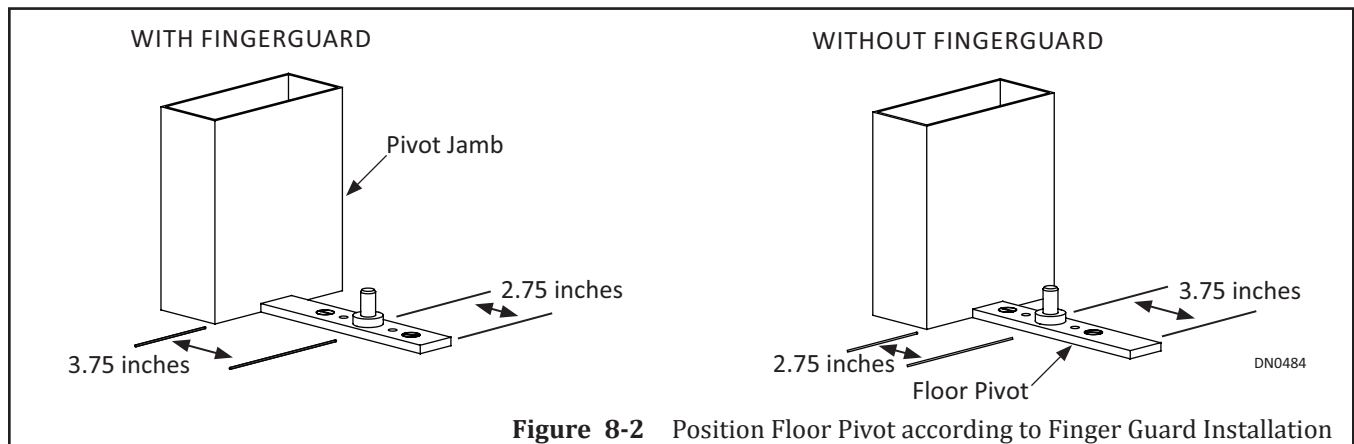


## CHAPTER 8: INSTALL THE FLOOR PIVOT



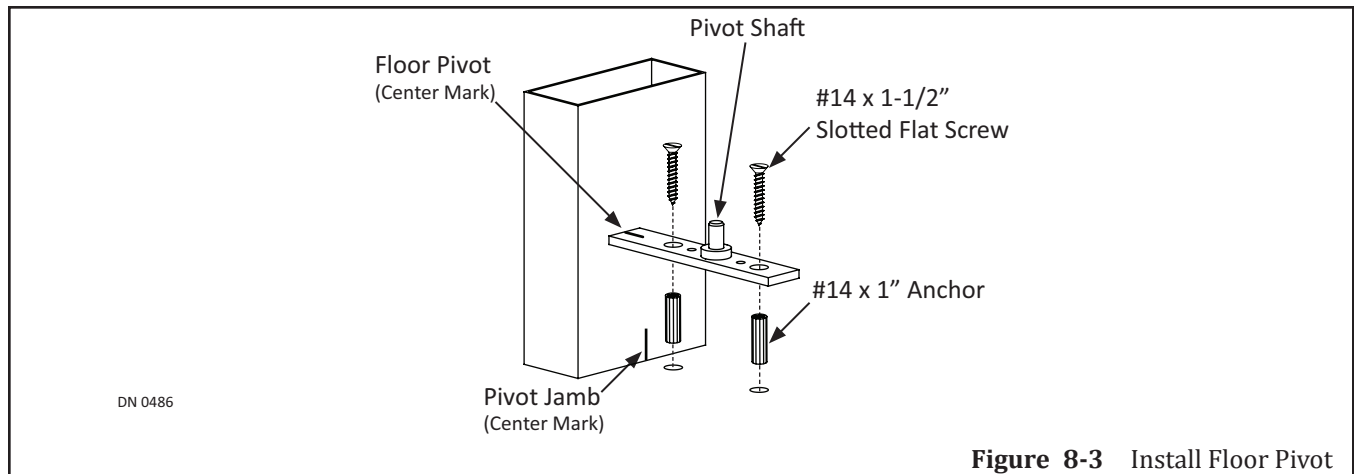
**Figure 8-1** Center Pivot Locations

1. Obtain the Floor Pivot Assembly.
2. The Pivot Shaft is not centered on the Floor Pivot. One end is used:
  - ▶ With the Finger Guard; so the Pivot Shaft measures 3.75 inches away from the Pivot Jamb.
  - ▶ Without the Finger Guard; so the Pivot Shaft measures 2.75 inches away from the Pivot Jamb.

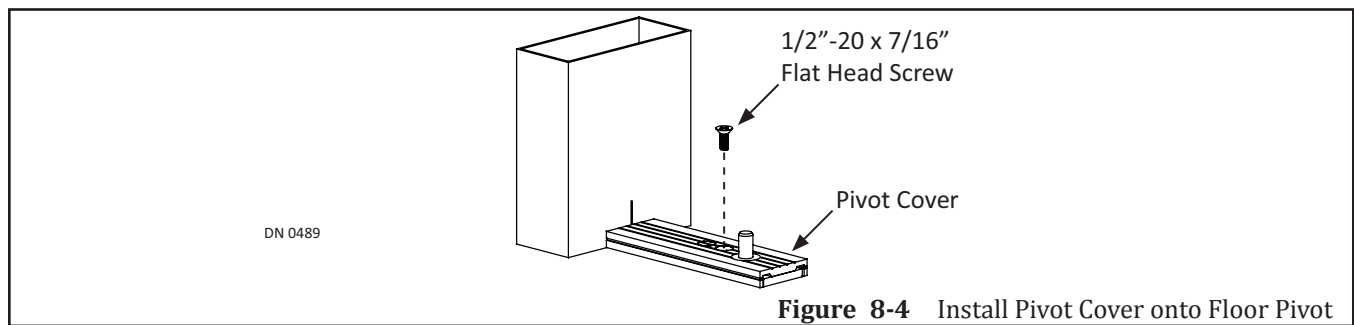


**Figure 8-2** Position Floor Pivot according to Finger Guard Installation

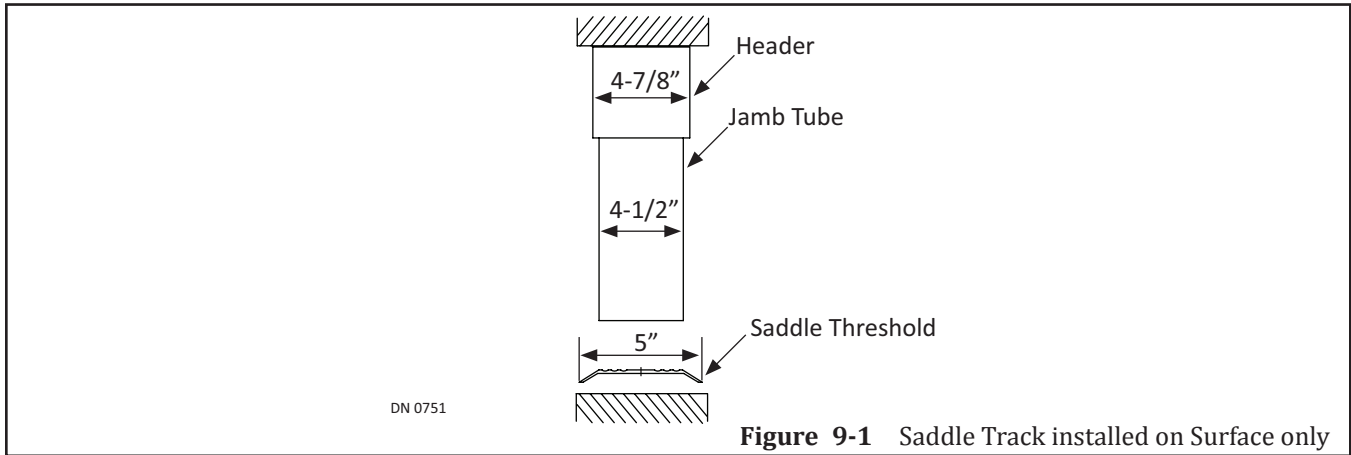
3. Measure and mark the center of the Pivot Jamb and the Floor Pivot. Please see Figure 8-3.
4. Butt the center mark of the Floor Pivot up against the center mark of the Pivot Jamb.
5. Align both Pivot Shafts. Drop a Plumb Line from the Top Pivot Shaft to the Floor Pivot Shaft.
  - a. The Plumb Line must drop down the center.
6. Use the Floor Pivot as a template to mark and drill (2) holes for #14 x 1 inch Blue anchors provided by NABCO.
7. Insert (2) #14 x 1" Blue anchors into each anchor hole.
8. Secure the Floor Pivot with (2) #14 x 1-1/2 inch Slotted Flat Head Screws provided by NABCO.



9. Secure the Pivot Cover onto the Floor Pivot with (1) 1/2"-20 x 7/16 inch Flat Head Machine Screw. Please see Figure 8-4.

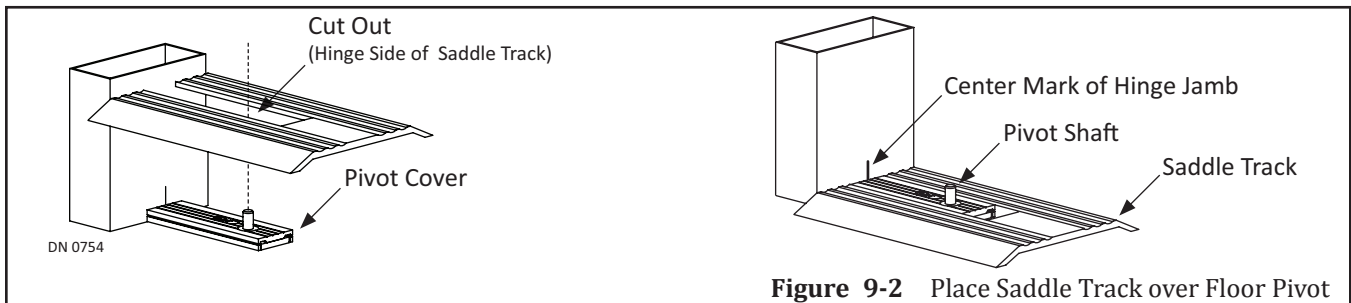


## CHAPTER 9: INSTALL THE SADDLE THRESHOLD



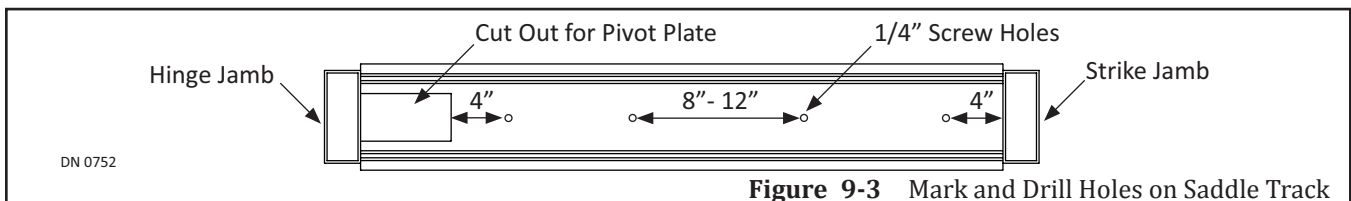
**Figure 9-1** Saddle Track installed on Surface only

1. Obtain the Saddle Threshold. The Pivot Side of the Saddle Threshold has a cut out for the Pivot Plate. Place the Pivot Side of the Saddle Threshold over the Floor Pivot Assembly. Please see Figure 9-2.
  - a. Ensure the Saddle Track is centered to the Strike Jamb and square.



**Figure 9-2** Place Saddle Track over Floor Pivot

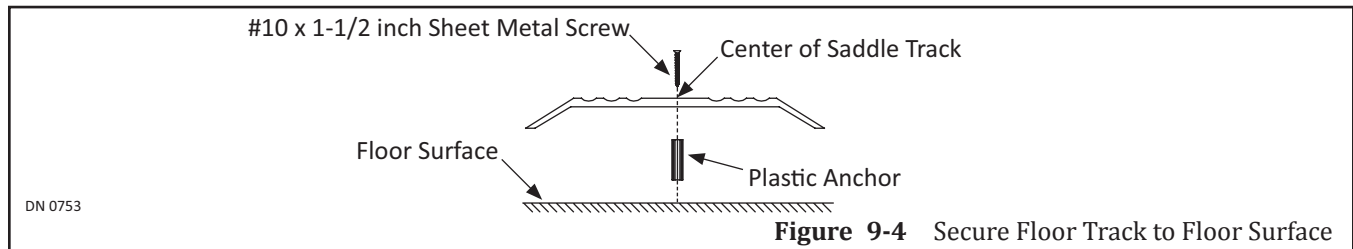
2. Square and center the Saddle Threshold to the Strike Jamb.
3. Obtain #10 x 1-1/2 inch sheet metal screws and anchors (Not provided by NABCO).
  - a. The number of screws and anchors depends upon the length of the Saddle Threshold.
4. In the center of the Saddle Threshold, approximately 4 inches from the cutout for the Pivot Plate, mark (1) screw hole. Please see Figure 9-3.
5. In the center of the Saddle Threshold, approximately 4 inches from the Strike Jamb, mark (1) screw hole.



**Figure 9-3** Mark and Drill Holes on Saddle Track

6. Mark remaining screw holes 8 - 12 inches apart and evenly spaced.

7. Drill screw holes into the floor no less than 1-1/2 inch deep for #14 x 1" anchors.
8. Remove the Saddle Threshold. Set aside.
9. Insert #14 x 1" plastic anchors into the drilled screw holes. Please see Figure 9-4.
10. Secure the Floor Track with #10 x 1-1/2 inch sheet metal screws (Not provided by NABCO).
  - a. Do not overtighten screws to prevent deforming the Saddle Threshold.

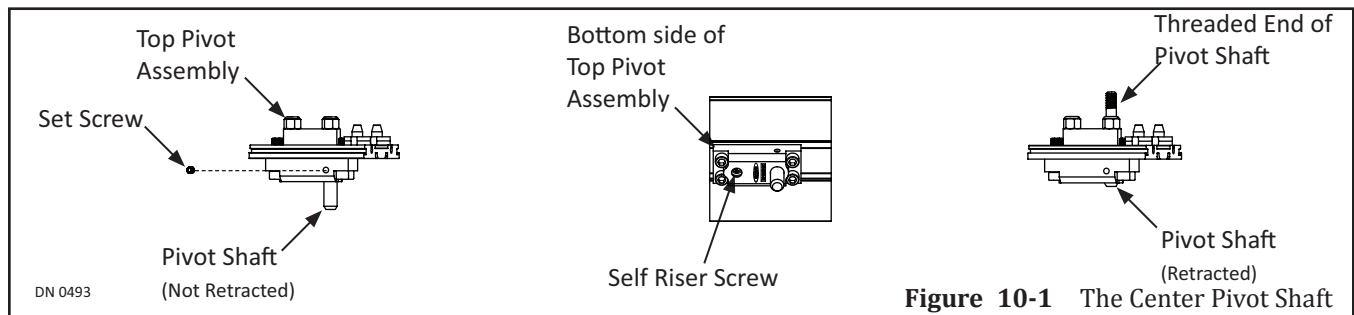


## CHAPTER 10: INSTALL THE SWING DOOR

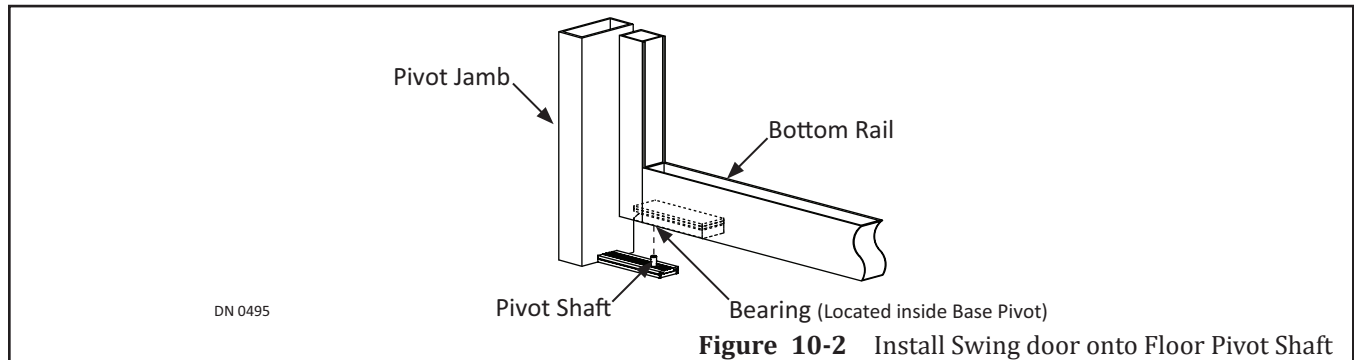
### Section 10a: Install the NABCO Swing Door

**FOR SWING DOORS NOT PROVIDED BY NABCO SKIP TO  
SECTION 10B**

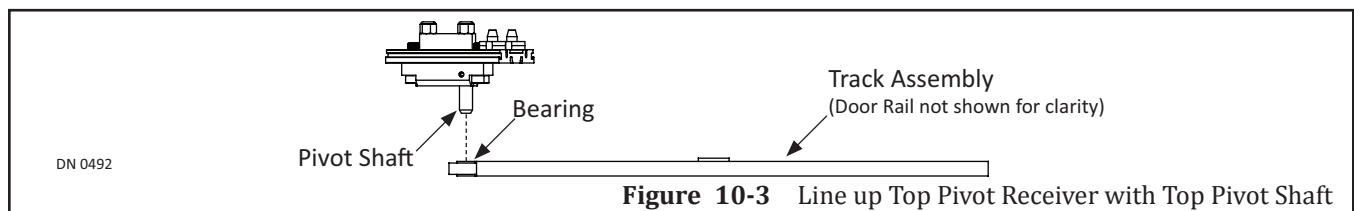
1. Go to the Pivot side of Header.
2. Loosen the Set Screw located directly above the Pivot Shaft. Please see Figure 10-1.
3. Go to the Self Riser screw located underneath the top Pivot.
4. Turn the Self Riser Screw counter-clockwise to retract the Center Pivot Shaft.



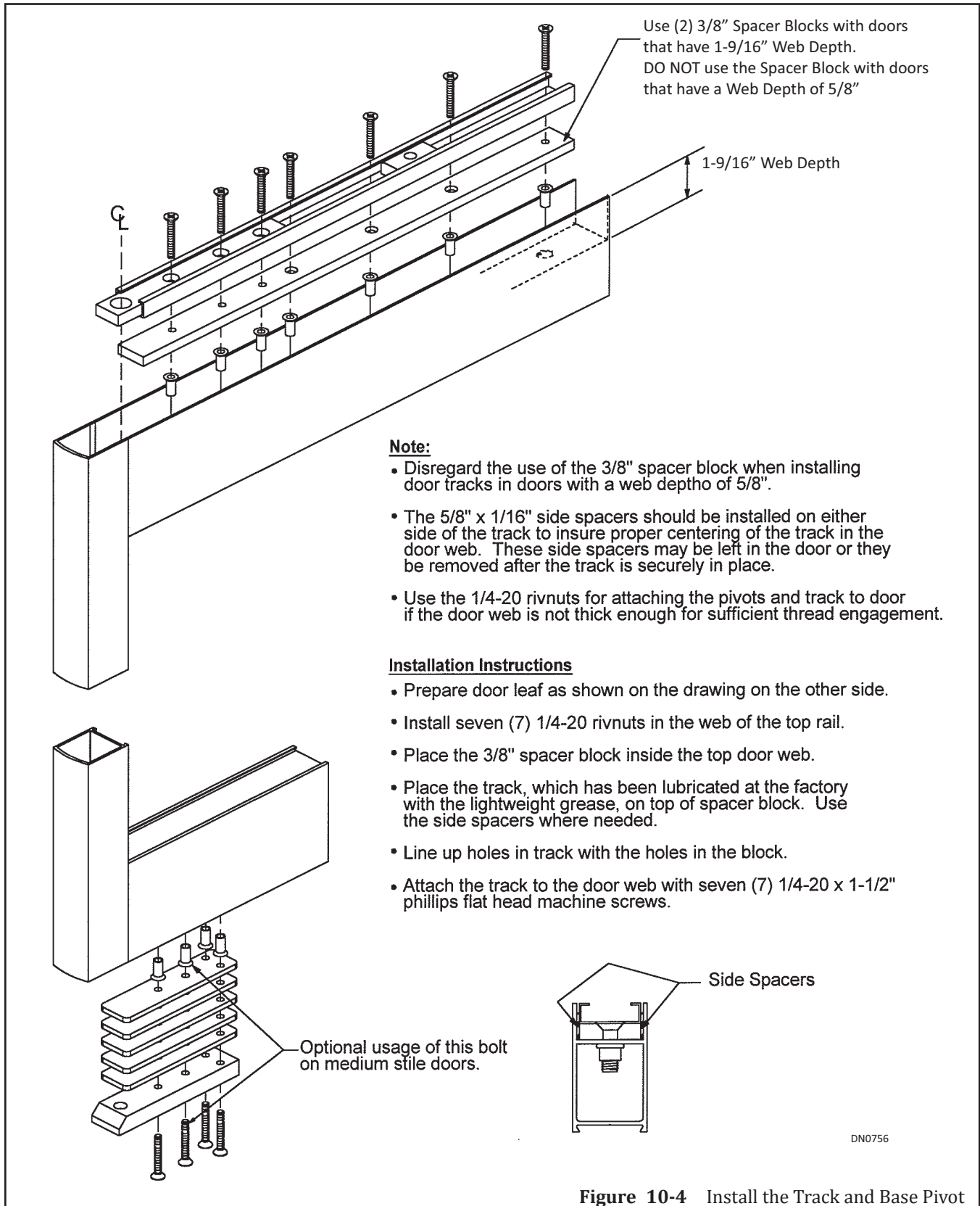
5. Go to the bottom Pivot Assembly. Locate the Ball Bearing. Insert the Ball Bearing onto the Floor Pivot Shaft. Please see Figure 10-2.



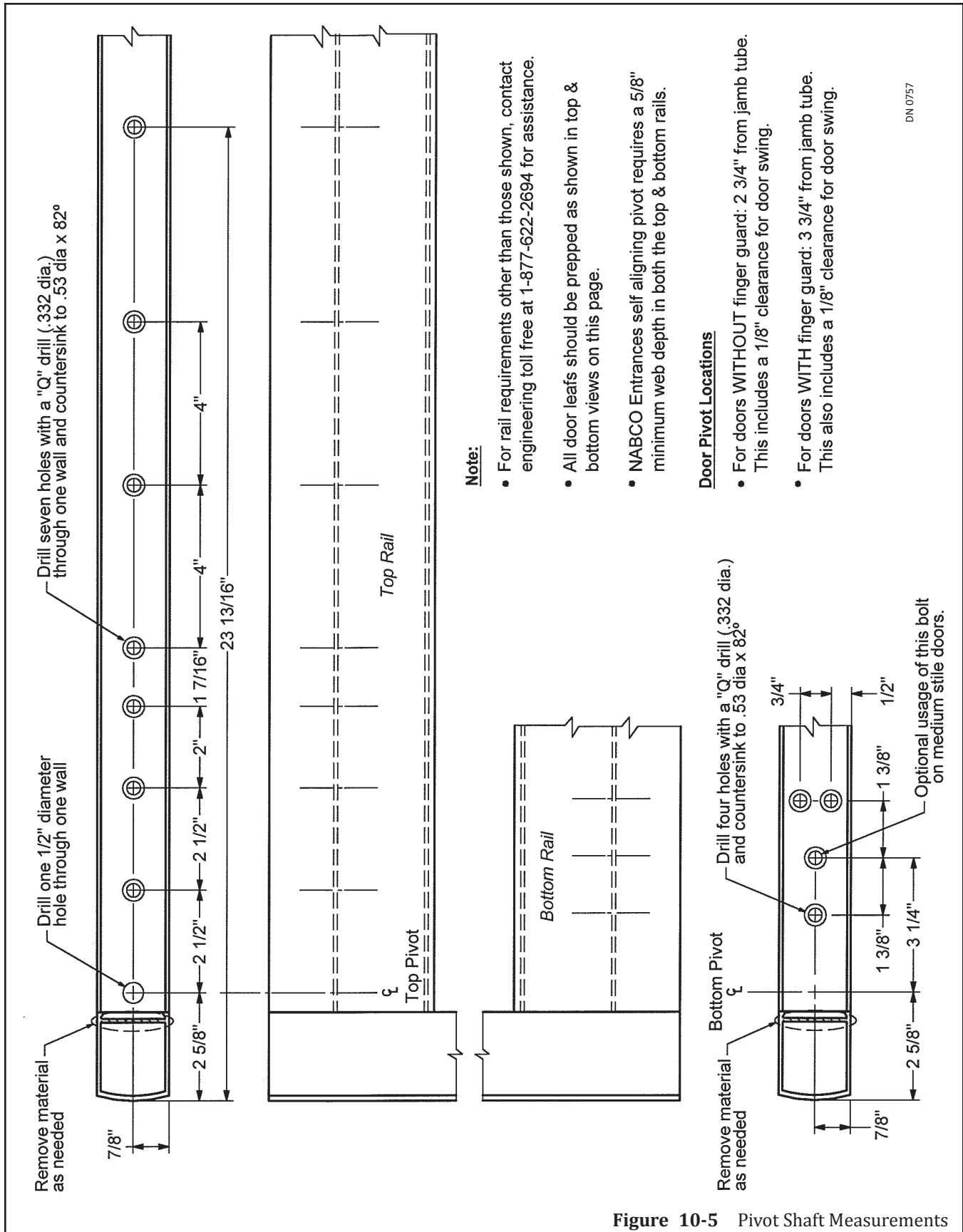
6. Go to the Top Rail. Locate the Track Assembly. Please see Figure 10-3.
7. With a flat head screwdriver, turn the Self Riser Screw clockwise until the Riser Bar is all the way down into the Bearing.
  - a. Tighten the Riser Bar tight to the base Pivot Plate to ensure the Pivot Shaft is fully engaged inside the Bushing.



**Section 10b: Install the Swing Door (Not provided by NABCO)**



**Figure 10-4** Install the Track and Base Pivot

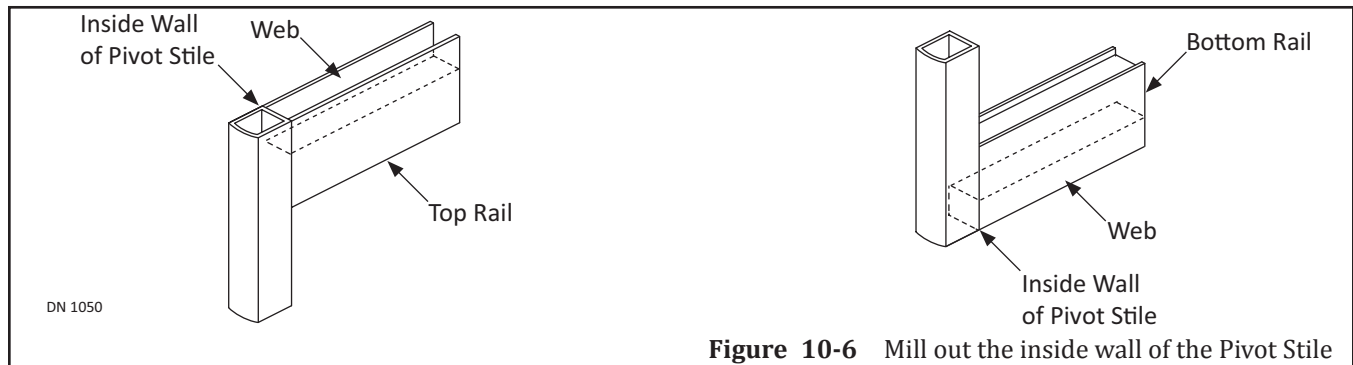


DN 0757

Figure 10-5 Pivot Shaft Measurements

### 10.b.a: Prep the Door Rail

The inside wall of the Pivot Stile may butt up against the Door Rail (at the very top). If the Track needs to extend past the Door Rail, the inside wall will need to be milled out to match the width and depth of the Web. This may need to be done to the top Door Rail and/or the bottom Door Rail. Please see Figure 10-6.



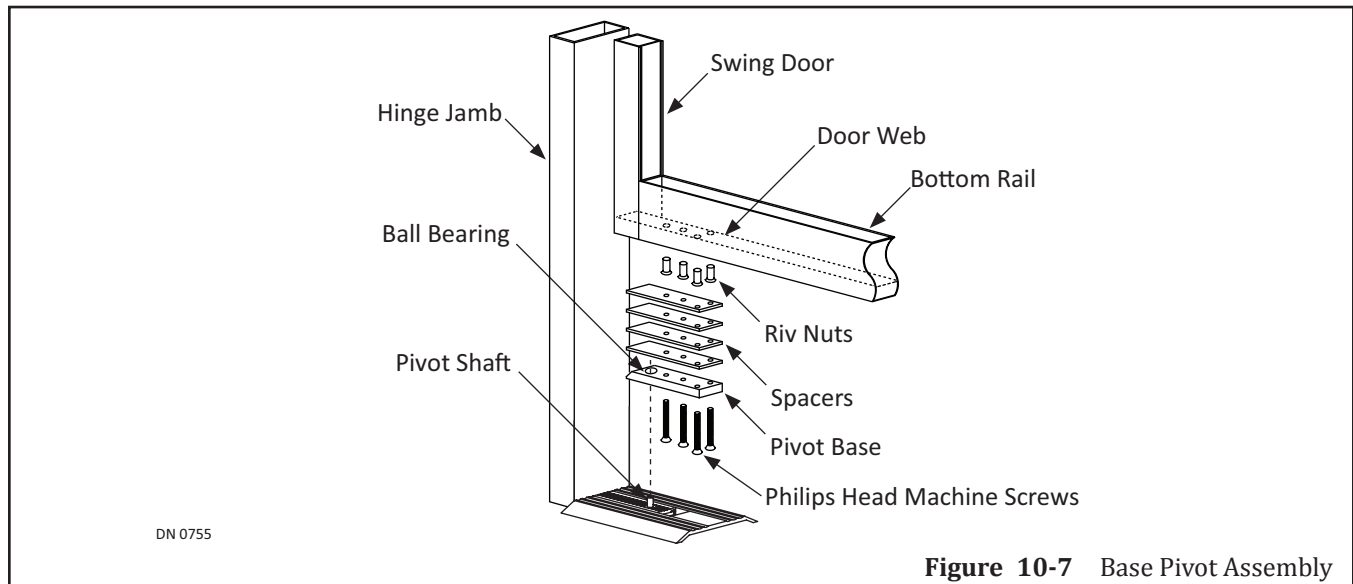
**Figure 10-6** Mill out the inside wall of the Pivot Stile

### 10.b.b: Install the Base Pivot into the Bottom Door Rail

1. Lay the Swing door on a flat surface that is sturdy enough to keep the door stable, and high enough to see while drilling.
  - a. Protect Swing door from scratches.
2. Please refer to Figure 10-5 for detailed Base Pivot installation measurements.
3. Go to the Bottom Rail on the Pivot side of Swing Door. Measure to find the center inside the Web. Mark a horizontal line all the way across the full width of the Web face.
4. From the outer edge of the Pivot Stile measure:
  - ▶ With the Finger Guard; 3-5/8 inches.
  - ▶ Without the Finger Guard; 2-5/8 inches.
5. Mark a vertical line across the horizontal line onto the Web face. This is the center of the Bearing.
6. From that mark, measure another 3-1/4 inches. Mark a vertical line across the horizontal line onto the Web face. This is the center of the second .322 diameter anchor hole.
7. Obtain (1) Spacer. Center the Spacer inside the Web. Align the second screw hole to the second anchor hole marked onto the Web face.
8. Use the Spacer as a template to mark the remaining (3) anchor holes.
  - a. Ensure the Spacer is aligned and centered.
  - b. Refer to Figure 10-5 for detailed measurements.
9. Drill (4) .322 anchor holes.
10. Countersink the (4) anchor holes to .53 diameter x 82 degrees.
  - a. It is recommended to drill tap threads for anchors in a steel or aluminum structure.
11. Insert (4) 1/4-20 tapped Rivnuts into the (4) .322 anchor holes.
12. Obtain the Base Pivot assembly. Please see Figure 10-7.
13. Place (1-4) Spacers on the bottom side of the Pivot Base.
  - a. The Gel filled Bearing is located on the top side of the Pivot Base.



14. Insert the Pivot Base assembly up into the Web.
  - a. Add/subtract spacers until the Base Pivot is flush to the outside edge of the Door Rail.
15. Secure the Pivot Base to the Web with (4) 1/4 - 20 x 2 inch Phillips Head Machine Screws.



**Figure 10-7** Base Pivot Assembly

### 10.b.c: Partially Install the Track inside the Top Door Rail

1. Lay the Swing door on a flat surface that is sturdy enough to keep the door stable, and high enough to see while drilling.
  - a. Protect Swing door from scratches.
2. Please refer to Figure 10-5 for detailed Track installation measurements.
3. Go to the Top Rail on the Pivot side of Swing Door. Measure to find the center inside the Web. Mark a horizontal line all the way across the full width of the Web face.
4. From the outer edge of the Pivot Stile measure 23-13/16 inches. Mark a vertical line across the horizontal line onto the Web Face. This is the center of (1) .322 anchor hole.
5. Drill (1) .322 anchor hole.
6. Countersink the anchor hole to .53 diameter x 82 degrees.
  - a. It is recommended to drill tap threads for anchors in a steel or aluminum structure.
7. Insert (1) 1/4-20 tapped Rivnut into the .322 anchor hole.
8. Obtain the Track Assembly. Please see Figure 10-8.
9. Place (1) Spacer Block inside the Web according to the Web Depth:
  - ▶ 5/8 inch deep: No Spacer Block is required
  - ▶ 7/8 inch deep: Insert 1/4 inch Spacer Block
  - ▶ 1 inch deep: Insert 3/8 inch Spacer Block
  - ▶ 1-9/16 inch deep: Insert (2) 3/8 inch Spacer Blocks
10. Place (1) Track on top of the Spacer Block (or the Web if a Spacer Block is not used).
  - a. Ensure the Pivot Pin Receiver is on the Pivot Side of the Web.
11. Place (2) 5/8 " x 1/16" Side Spacers on either side of the Track.
  - a. Side Spacers are used to ensure proper centering of Track.

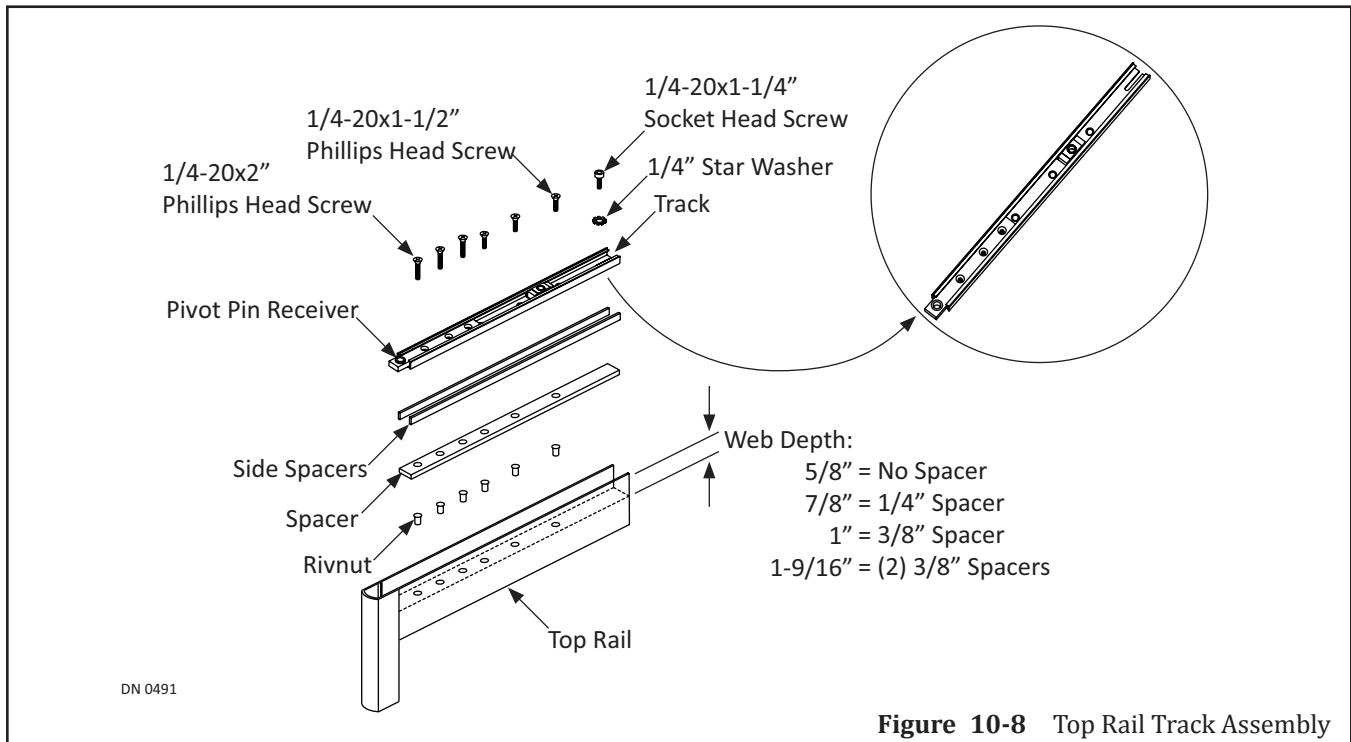


Figure 10-8 Top Rail Track Assembly

12. From the outer edge of the Pivot Stile measure:
  - ▶ With the Finger Guard; 3-5/8 inches.
  - ▶ Without the Finger Guard; 2-5/8 inches
13. Slide the Track towards the Pivot Stile or away from the Pivot Stile until the Bearing is centered to that measurement. Please see Figure 10-9.
14. Locate the Slot at the end of the Track. Locate the Pre-drilled screw hole.
15. Secure the Track to the Web with (1) 1/4 inch Star Washer and (1) 1/4-20x1-1/4 inch Socket Head screw. Tighten but do not overtighten. The Socket Head screw may need to be loosened one more time.

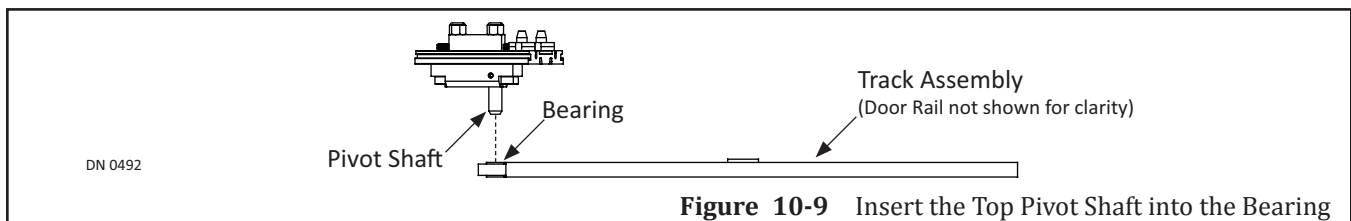
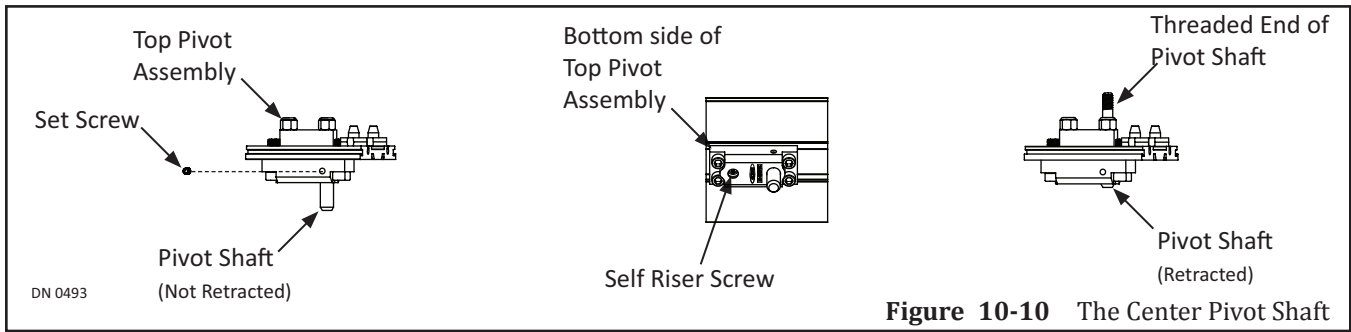


Figure 10-9 Insert the Top Pivot Shaft into the Bearing

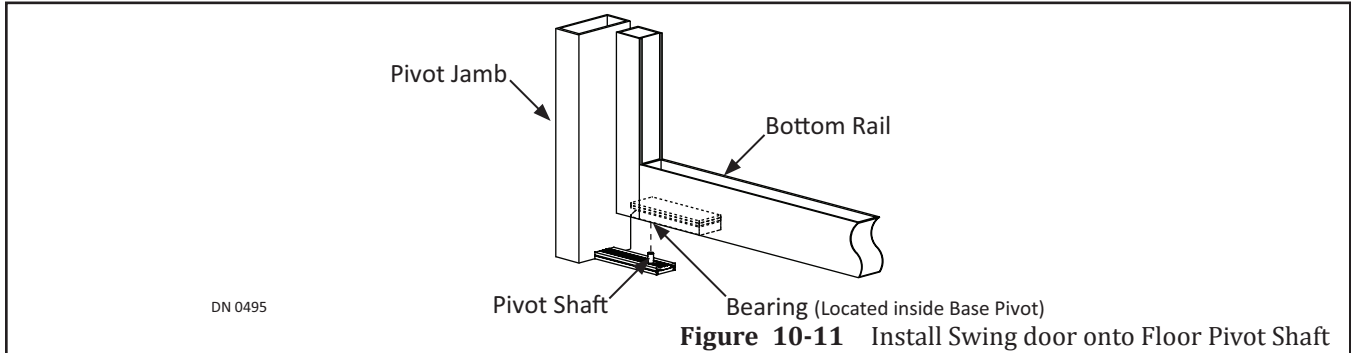
#### 10.b.d: Temporarily Install the Swing Door

1. Go to the Pivot side of Header. Locate the Pivot Assembly.
2. Loosen the Set Screw located directly above the Pivot Shaft. Please see Figure 10-10.
3. Go to the Self Riser screw located underneath the Pivot Assembly.
4. Turn the Self Riser Screw counter-clockwise to retract the Pivot Shaft.



**Figure 10-10** The Center Pivot Shaft

5. Go to the bottom Door Rail. Slide the Bearing onto the Pivot Shaft. Please see Figure 10-11.

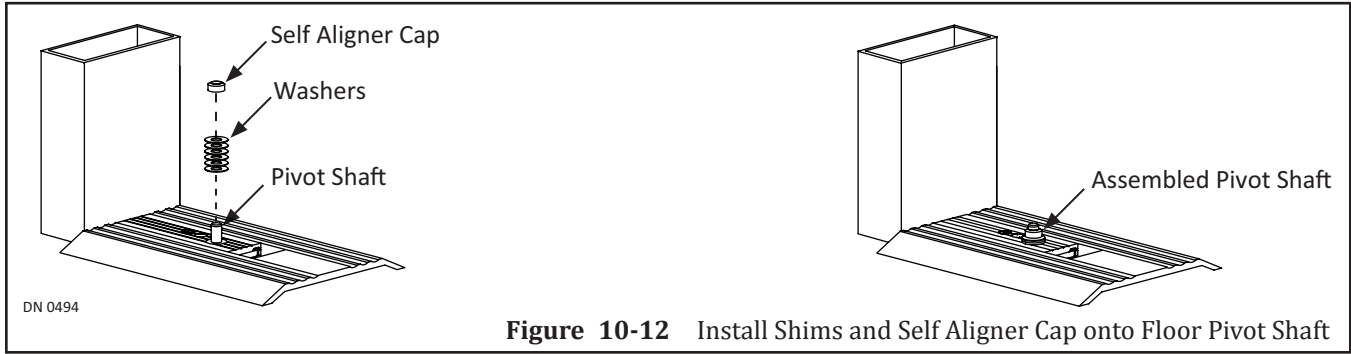


**Figure 10-11** Install Swing door onto Floor Pivot Shaft

6. Go to the top Door Rail. Turn the Self Riser Screw clockwise to insert the Pivot Shaft into the Bearing. Please see Figure 10-10.
7. With a flat head screwdriver, turn the Self Riser Screw clockwise until the Pivot Shaft is inserted all the way down into the Bearing.
8. Tighten the Set Screw, do not overtighten. The Set Screw may have to be loosened one more time.

**10.b.e: Adjust the Swing Door Height**

1. Measure for proper clearance:
  - ▶ Top of Swing door must be: 1/8 inch to 1/16 inch from Header
  - ▶ Bottom of Swing door must be: 3/16 inch to 1/16 inch from Floor (or threshold)
2. Remove the Swing door.
3. Slide (1-6) Spacer Shims onto the Pivot Shaft to adjust the Swing door for proper clearance.
4. Slide (1) Self Aligner Cap on top of the (1-6) Spacer Shims. Reinstall the Swing door.



**Figure 10-12** Install Shims and Self Aligner Cap onto Floor Pivot Shaft

**10.b.f: Align the Swing Door**

1. Fully open the Swing door.
2. Go to the Track Assembly located inside the Top Rail.
3. Loosen (1) 1/4-20x1-1/4 inch Socket Head Screw.
4. Slide the Track Assembly back and forth until the Swing door is properly aligned.
  - a. It is recommended to use a Level.
5. Tighten the Socket Head Screw but do not tighten all the way down.
  - a. The Socket Head Cap Screw may need to be loosened one more time.

**10.c.g: Permanently Install the Track inside the Top Door Rail**

1. Fully open the Swing door.
2. Use the Track as a template. Mark a vertical line across the horizontal line inside each pre-drilled screw hole. Each mark is the center of (6) .322 anchor holes.
3. Remove the Swing door.
4. Lay the Swing door on a flat surface that is sturdy enough to keep the door stable, and high enough to see while drilling.
  - a. Protect Swing door from scratches.
5. Drill (6) .322 anchor holes.
6. Countersink the anchor hole to .53 diameter x 82 degrees.
  - a. It is recommended to drill tap threads for anchors in a steel or aluminum structure.
7. Insert (6) 1/4-20 tapped Rivnut into each .322 anchor hole.
8. Secure the Track to the Web with (3) 1/4-20x2 inch Socket Head screws and (3) 1/4-20x1-1/2 inch Phillips Head screws. Tighten but do not overtighten. Please see Figure 9-13.

**10.c.h: Permanently Install the Swing Door**

1. Follow instructions within subsection 10.b.d.

## CHAPTER 11: INSTALL THE SWING ARM

### Section 11a: Set Pre-Load

#### WARNING

Proper Preload is critical for the Control and Operator to open/close the Swing Door correctly.

#### CAUTION

Power must be turned OFF during the Swing Arm installation.

#### DANGER

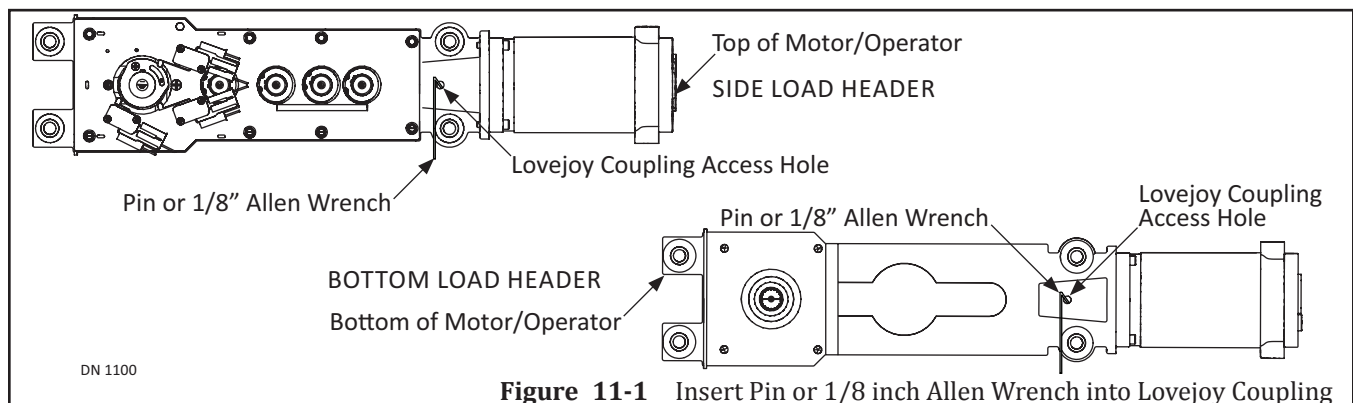
Ensure the Motor/Operator is plugged into the Controller.

1. Ensure the Spring on the Operator is in the Unwound (0°) position.
  - a. The Motor/Operator is shipped in the Unwound (0°) position.
2. Obtain (1) Pin or 1/8 inch Allen Wrench.
3. Go underneath the Header. Locate the Operator Spindle.
4. Slide the Swing Arm onto the Spindle.
5. In order to achieve correct Back Check and Latch Check positions, the Spring on the Operator must be wound up approximately 130 - 140 degrees. With a firm grip, from the Unwound (0 degree) position, rotate the Swing Arm approximately 60 degrees:
 

▶ Clockwise	▶ Counter-Clockwise
• For Left Handing	• For Right Handing
6. While holding the Swing Arm in that position, insert (1) Pin or 1/8 inch Allen Wrench into the Lovejoy Coupling Access Hole. Please see Figure 11-1.
  - a. It may be necessary to ease the Swing Arm back until the Pin or 1/8 inch Allen Wrench engages the Lovejoy Coupling.

#### DANGER

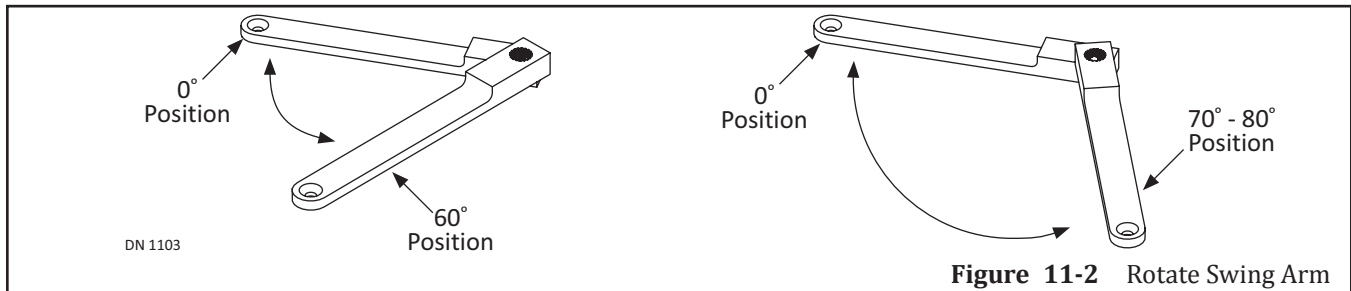
Do not allow the Pin or 1/8 inch Allen Wrench to drop out of the Lovejoy Coupling Access hole at any time during installation. The Swing Arm will spring back to its original location and can result in personal injury or damage.



**Figure 11-1** Insert Pin or 1/8 inch Allen Wrench into Lovejoy Coupling

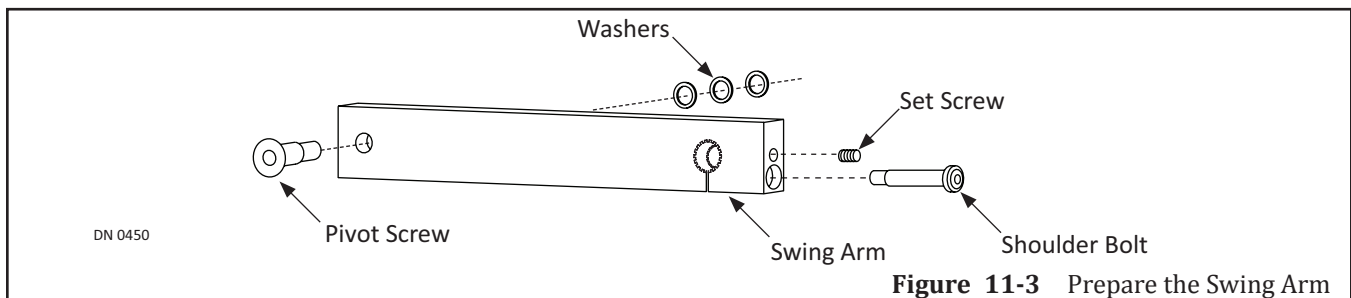
7. Remove the Swing Arm from the Operator Spindle.
  - a. The Pin or 1/8 inch Allen Wrench will keep the Spring from unwinding.

8. Go to the 0 degree position again, slide the Swing Arm back onto the Operator Spindle. Please see Figure 11-2.
9. With a firm grip, slightly remove pressure from the Spring to allow removal of the Allen wrench. Continue to rotate the Swing Arm an additional 70-80 degrees. Re-insert the Allen wrench and then remove the Swing Arm.
  - a. The Spring on the Operator should be wound approximately 130 - 140 degrees.

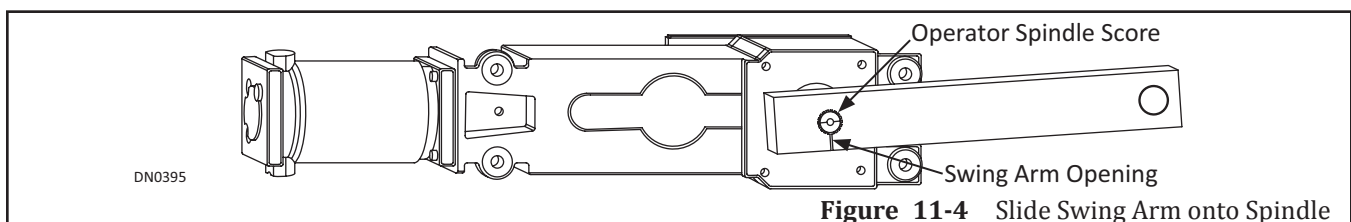


### Section 11b: Secure the Swing Arm

1. Obtain the Swing Arm.
2. With an 5/16 inch Allen Wrench, remove the Pivot Screw and (3) washers. Set aside. Please see Figure 11-3.
3. Remove the Set Screw to loosen the Shoulder Bolt with an 3/16 inch Allen Wrench. Set aside.

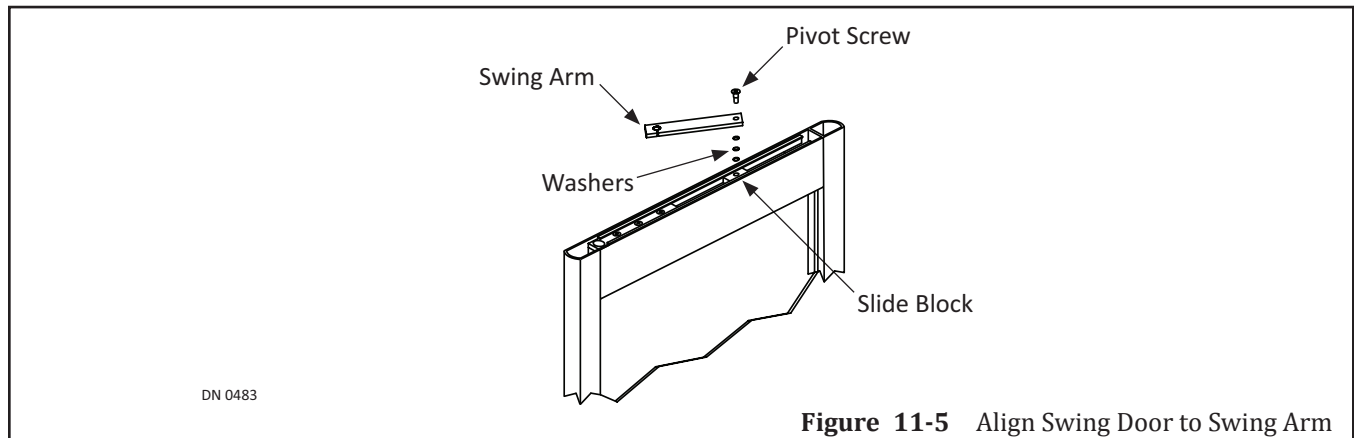


4. Fully close the Swing door. Go to the Output Spindle located at the bottom of the Operator. Please see Figure 11-4.
  - a. A Score has been etched onto the bottom of Output Spindle.
5. Line up the Opening located on the bottom of the Swing Arm so it is perpendicular to the Spindle Score. Slide the Swing Arm onto the Spindle.

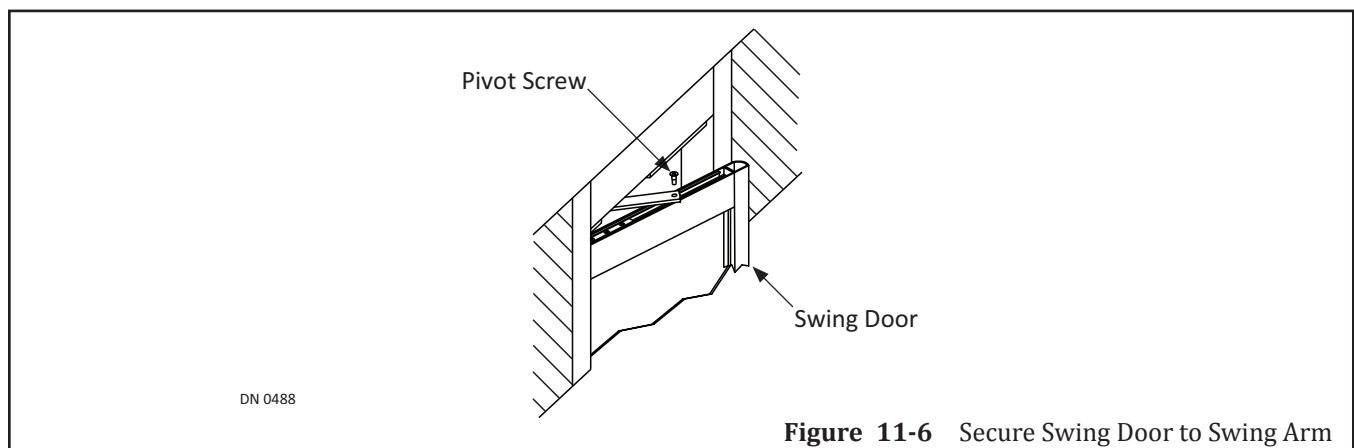


6. Obtain the Swing Arm's Pivot Screw and (3) Washers that were set aside during Pre-Load.

7. Open Swing Door to align the Top Slide Block with the Pivot Screw hole (located on free end of Swing Arm). Please see Figure 11-5.
8. Check to see how many Washers will be necessary to install between the Swing Arm and the Swing door.
  - ▶ 3 for 3/16 inch Clearance Door
  - ▶ 2 for 1/8 inch Clearance Door
  - ▶ 1 for 1/16 inch Clearance Door
9. Align Washers on top of the hole located on the Top Slide Block.
  - a. Hold washers in place.



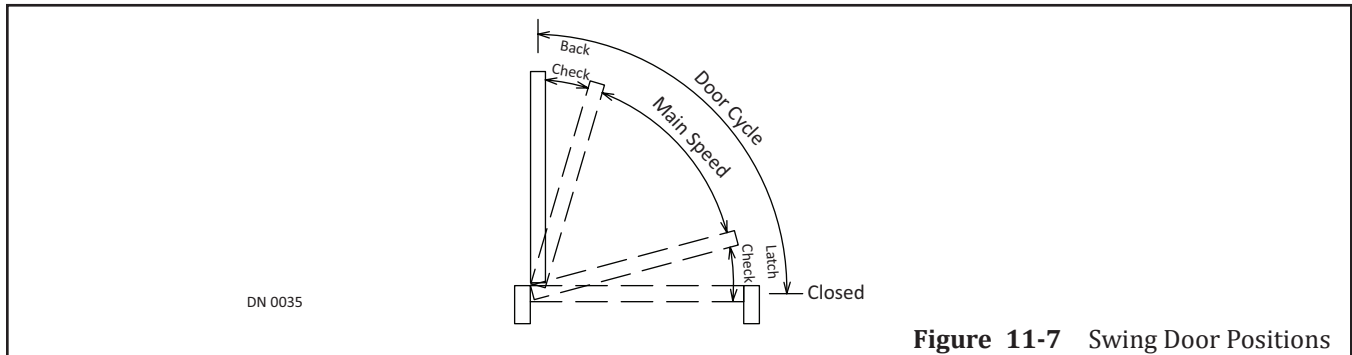
10. Align the Slide Block so it is aligned with the Pivot Screw hole again.
11. Secure the Swing Arm to the Slide Block with the Pivot Screw. Please see Figure 11-6.
  - a. Do not to overtighten Pivot Screw.



12. Secure the Swing Arm by reinstalling the Set Screw and tightening both the Shoulder Bolt plus Set Screw with an 5/16 inch Allen Wrench.
13. Remove the 1/8 inch Allen Wrench or similar tool from the Lovejoy Coupling Access hole.
  - a. The Swing door will close.
14. Go to the Rocker Switch. Flip the switch to ON.
  - a. This will activate the Swing door.

15. Go the Magnum 4A Control.
  1. When the Swing door opens, watch the Green LED go from Blinking Fast on opening, then Solid in Back Check to full open.
  2. When the Swing door closes, watch the Green LED go from Blinking slowly, to Flashing slowly when opening to Solid OFF for Latch Check (approximately 10° closed).

**Section 11c: Test the Pre-Load**



**Figure 11-7** Swing Door Positions

Position	Description
Opening	Range from fully closed to 10° from fully open.
Back Check	10° from fully open to fully open.
Closing	Range from fully open to 10° from fully closed.
Latch Check	10° from fully closed to fully closed.

1. Turn Power ON.
2. Open Swing Door.
  - a. Swing door should slow down at 75° - 80° open.
  - b. If Swing door stops at any other degree, Back Check needs to be adjusted.
3. Close Swing Door.
  - a. Swing door should slow down at 75° - 80° close.
  - b. If Swing door slows down at any other degree, Latch Check needs to be adjusted.



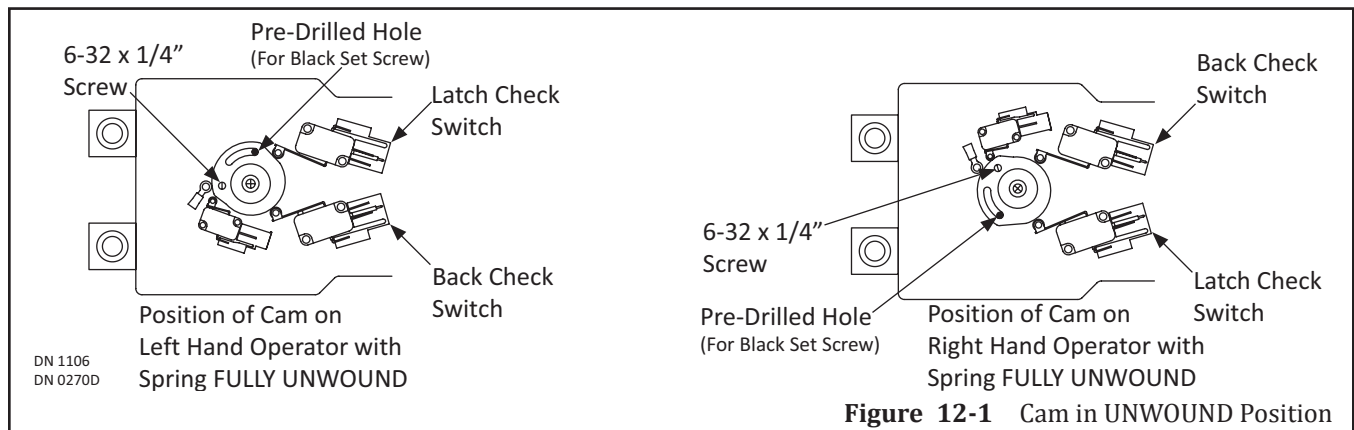
## CHAPTER 12: PRE-LOAD ADJUSTMENTS

*Note:* Adjustments to the Cam Assembly is rarely necessary. It is recommended to adjust the Cams Assembly as a last resort.

*Note:* It is recommended to obtain one of the following Manuals to use as reference:

- ▶ *Magnum 4A Manual; 15-10682*
- ▶ *Analog Control Manual; 15-10745*

The Cam Assembly is preset at the NABCO factory to activate Back Check/Latch Check at 90 degrees with the Operator Spring set in the UNWOUND position. Please see Figure 12-1.



**Figure 12-1** Cam in UNWOUND Position

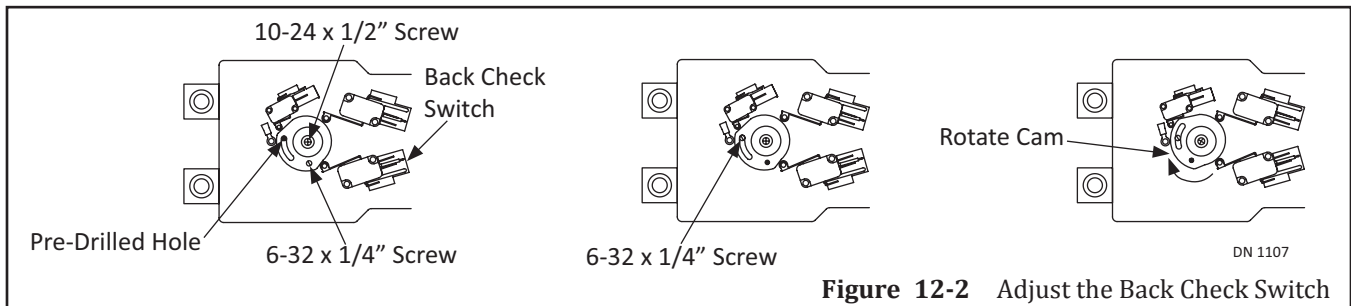
LEFT HAND OPERATOR MAGNUM CONTROL		RIGHT HAND OPERATOR MAGNUM CONTROL	
Latch Check Switch Wires	White & Green	Back Check Switch Wires	Red & Blue
Back Check Switch Wires	Red & Blue	Latch Check Switch Wires	White & Green
ANALOG CONTROL		ANALOG CONTROL	
Latch Check Switch Wires	Orange & Brown	Back Check Switch Wires	Yellow, White & Blue
Back Check Switch Wires	Yellow, White & Blue	Latch Check Switch Wires	Orange & Brown

### Section 12a: Rotate the Cam for Back Check

#### 12.a.a: Bottom Load Units

1. Go to the top of Header. Remove to the Cover used to protect the access hole located directly above the Cam Assembly.
2. Go inside the Header. Remove the Cover used to protect the Cam Assembly. Set Aside.
  1. Remove the 6-32 x 1/4 inch screw. Please see Figure 12-2.
  2. Go to the c-shaped slot located to the Left or Right of the 6-32 x 1/4 inch screw. Locate (1) pre-drilled hole.
  3. Insert the 6-32 x 1/4 inch screw inside the pre-drilled hole.
  4. Tighten, but only so the 6-32 x 1/4 inch screw does not fall out of the Slot.

5. Go to the middle of the Cam. Loosen the 10-24 x 1/2 inch screw.
6. Rotate the Cam until the appropriate Back Check position has been achieved.



**Figure 12-2** Adjust the Back Check Switch

7. Tighten down both the 6-32 x 1/4 inch screw and 10-24 x 1/2 inch screw.
8. Replace both Covers.

### 12.a.b: Side Load Units

1. Go inside the Header. The Cam Assembly can be adjusted from the side.
  - a. A Switch Assembly Cover is not installed on a Side Load Header.
2. Remove the 6-32 x 1/4 inch screw with a 1/4 inch open end wrench. Please see Figure 12-2.
3. Go to the C-shaped slot located to the Left or Right of the 6-32 x 1/4 inch screw. Locate (1) pre-drilled hole.
4. Insert the 6-32 x 1/4 inch screw inside the pre-drilled hole.
5. Tighten, but only so the 6-32 x 1/4 inch screw does not fall out of the Slot.
6. Go to the middle of the Cam. Loosen the 10-24 x 1/2 inch screw with a 5/16 inch box or open end wrench.
7. Rotate the Cam until the appropriate Back Check position has been achieved.
8. Tighten down both the 6-32 x 1/4 inch screw and 10-24 x 1/2 inch screw.

### Section 12b: Adjust the Swing Arm for Latch Check

Latch Check positions can not be adjusted by rotating the Cam. Adjustments must be accomplished by removing, and then sliding the Swing Arm back onto the Operator Spindle to the left or right of the last position.