

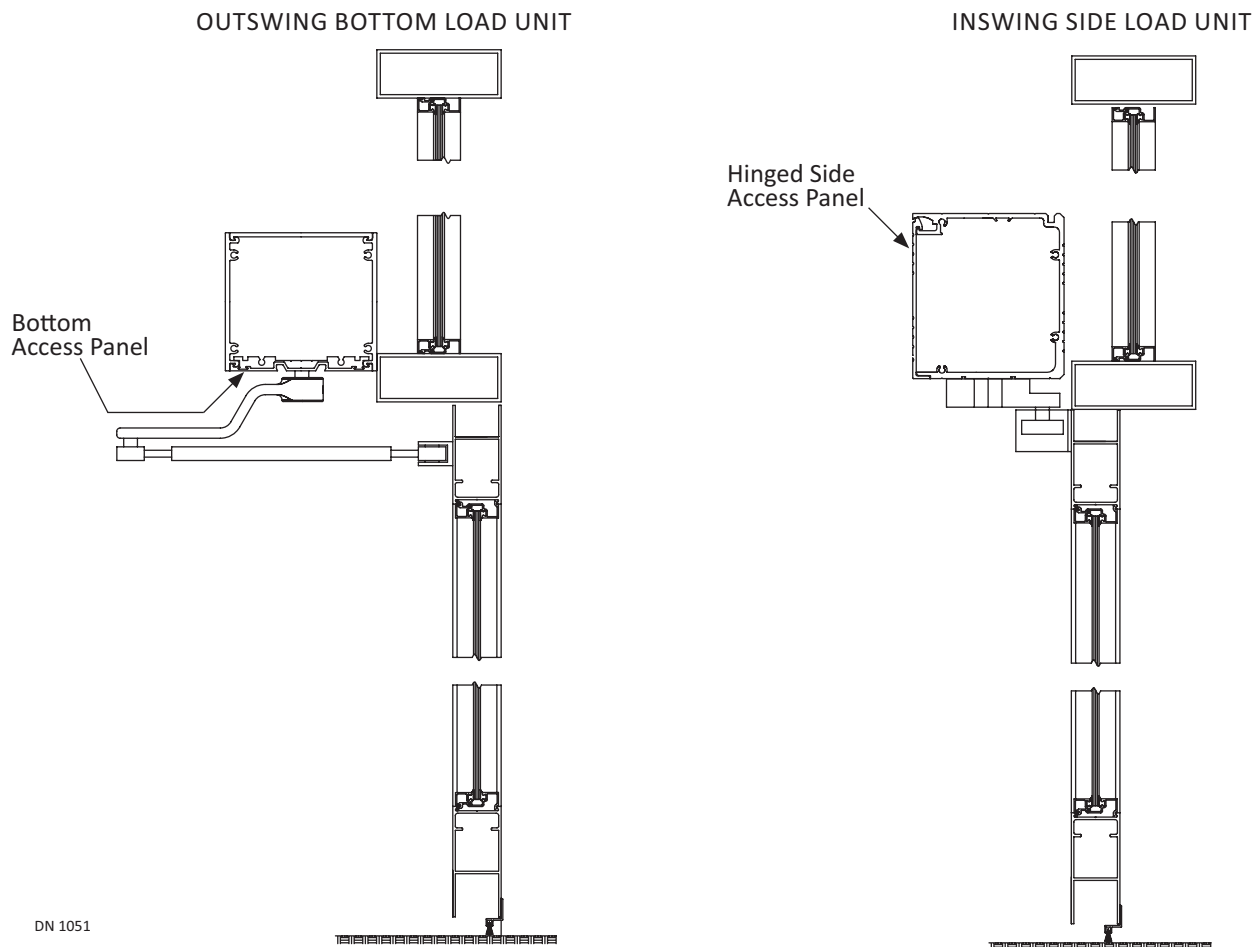

S82 W18717 Gemini Drive
Muskego, Wisconsin 53150
Phone: (877) 622-2694
Fax: (888) 679-3319
www.nabcoentrances.com
Technical Support: (866) 622-8325

Conversion Unit Swing Door Systems

Bottom Load Units: GT400 and GT500 and GT600
Side Load Units: GT8400 and GT8500 and GT8600



DN 1051

WARNING

- Turn OFF all power to the Automatic Door if a Safety System is not working.
- Instruct the Owner to keep all power turned OFF until corrective action can be achieved by a NABCO trained technician. Failure to follow these practices may result in serious consequences.
- NEVER leave a Door operating without all Safety detection systems operational.

Part #15-10538
Rev. 9/26/14

THIS PAGE IS INTENTIONALLY LEFT BLANK

Table of Contents

Warning Labels iii

General Safety Recommendations iv

CHAPTER 1: SCOPE.1-5

 Section 1a: To the Installer1-5

 Section 1b: Objective.1-5

CHAPTER 2: GETTING STARTED2-6

 Section 2a: Mechanical Configurations2-6

 Section 2b: Electrical Standards2-6

 Section 2c: Installation Specifications2-6

 Section 2d: Base Unit Types2-6

 Section 2e: Header Types2-7

 Section 2f: How to Determine Handing2-7

 Section 2g: Swing Door Types2-8

 Section 2h: Control Types2-9

 Section 2i: Associated Manuals Part Numbers2-9

 Section 2j: Service Parts Pages2-9

CHAPTER 3: INSTALL THE BOTTOM LOAD HEADER. 3-10

 Section 3a: Prepare the Header3-10

 Section 3b: Prepare the Door Frame3-10

 Section 3c: Install Shim behind Header (Only if deemed necessary)3-11

 Section 3d: Secure Header to the Door Frame3-12

CHAPTER 4: INSTALL BOTTOM LOAD COMPONENTS. 4-13

 Section 4a: Secure Incoming Wires4-13

 Section 4b: Install the Stop Ring.4-13

 Section 4c: Install the Motor/Operator4-14

 Section 4d: Install the Control.4-15

 Section 4e: Install Optional Components.4-16

CHAPTER 5: INSTALL THE SIDE LOAD HEADER 5-17
Section 5a: Inswing Doors5-17
Section 5b: Prepare the Header5-17
Section 5c: Prepare the Door Frame5-18
Section 5d: Install Shim (Only if deemed necessary)5-19
Section 5e: Secure Header to the Door Frame5-19

CHAPTER 6: 110 VAC GENERAL WIRING 6-20

CHAPTER 7: INSTALL THE FIRST HALF OF SWING ARM 7-21
Section 7a: Outswing Arm7-21
Section 7b: Inswing Arm7-23

CHAPTER 8: INSTALL THE SECOND HALF OF SWING ARM 8-25
Section 8a: Set Pre-Load8-25
Section 8b: Secure the Swing Arm to the Swing Door8-26
Section 8c: Test the Pre-Load8-28
Section 8d: Install the Arm Stop (Side Load Units)8-28

CHAPTER 9: MAGNUM GENERAL WIRING 9-30
Section 9a: GT-400-500-600-8400-8500-8600 Single Swing Door9-30
Section 9b: GT-400-500-600-8400-8500-8600 Simultaneous Swing Door9-31

CHAPTER 10: ADJUSTMENTS 10-32

WARNING LABELS

Warning labels are universal and used to alert an individual of potential harm to one's self or to others. The following warning labels are listed in a hierarchy order that defines the most potential danger first, and the least potential danger last. Please refer to this page in the event that a warning label is displayed within this manual and further definition needs to be explained.

DANGER

Indicates potentially dangerous situations. Danger is used when there is a hazardous situation where there is a *high* probability of severe injury or death. It should not be considered for property damage unless personal injury risk is present.

WARNING

Indicates a hazardous situation which has *some* probability of severe injury. It should not be considered for property damage unless personal injury risk is present.

CAUTION

Indicates a hazardous situation which *may result in a minor injury*. Caution should not be used when there is a possibility of serious injury. Caution should not be considered for property damage accidents unless a personal injury risk is present.

Notice: Indicates a statement of company policy as the message relates to the personal safety or protection of property. Notice should not be used when there is a hazardous situation or personal risk.

Note: Indicates important information that provides further instruction.

GENERAL SAFETY RECOMMENDATIONS

WARNING

Read this “General Safety Recommendations” section before installing, operating or servicing the automatic door. Failure to follow these practices may result in serious consequences.

Notice: Read, study and understand the operating instructions contained in, or referenced in this manual before operating. If you do not understand the instruction, ask the installing qualified technician to teach you how to use the door.

WARNING

Do not install, operate or service this product unless you have read and understand the General Safety Recommendations, Warning Labels, Installation and Operating Instructions contained in this manual. Failure to do so may result in bodily injury, or property damage.

Notice: This manual and the owner’s manual must be given to and retained by the purchasing facility or end user.

- ▶ If the door appears broken or does not seem to work correctly, it should be immediately removed from service until repairs can be carried out or a qualified service technician is contacted for corrective action.
- ▶ Disconnect power at the fused disconnect during all electrical or mechanical service. When uncertain whether power supply is disconnected, always verify using a voltmeter.
- ▶ All electrical troubleshooting or service must be performed by qualified electrical technicians and must comply with all applicable governing agency codes.
- ▶ It is the responsibility of the installing door technician to install all warning and instructional labels in accordance with ANSI 156.10 and ANSI 156.19.
- ▶ It is the responsibility of the purchasing facility or end user to keep warning and instructional labels and literature legible, intact and with the door.
- ▶ Replacement labels and literature may be obtained from local NABCO Entrances, Inc. distributors. If the name of the local distributor is unknown, contact NABCO Entrances, Inc. at 1-877-622-2694 for assistance.

DANGER

Do not place finger or uninsulated tools inside the electrical controller. Touching wires or other parts inside the enclosure may cause electrical shock, serious injury or death.

CHAPTER 1: SCOPE

Section 1a: To the Installer

The purpose of this manual is to familiarize the installer and purchaser with the proper installation and operation of this system. It is essential that this equipment be properly installed and operational before the door is used by the public. It is the installer's responsibility to inspect the operation of the entrance system to be sure it complies with any applicable standards. In the United States, ANSI Standard 156.10 (Full Power) and ANSI Standard 156.19 and ADA Standard (Low Energy) covers the Conversion Unit Swing Door System. Other local standards or codes may apply. Use them in addition to the ANSI standard. Both Full Power and Low Energy Swing door Units are listed with the Underwriters Laboratory and is identified as such on the label.

Instruct the building owners and operator on the essentials of the operation of the Swing door and this device. The owner should follow these instructions to determine whether the door is operating properly and should immediately call for service if there is any malfunction. All installation changes and adjustments must be made by qualified, NABCO trained technicians.

Section 1b: Objective

Swing Door Conversion Units are designed to be installed onto the top surface of the Door Frame. The Operator is controlled by the Magnum 4A Control (Standard) or by the Model 1400 Analog Control (Optional). Both Controls offer many features to accommodate most installation options. This manual offers step by step instructions.

CHAPTER 2: GETTING STARTED

Section 2a: Mechanical Configurations

Base Model	Conversion Unit Bottom Load	Conversion Unit Side Load
Full Power	GT 400	GT 8400
Low Energy	GT 500	GT 8500

Section 2b: Electrical Standards

Note: It is recommended for the Installer to use an Electrical Conduit to house all incoming 120 VAC wires.

Note: All wiring must conform to standard wiring practices and be in accordance with national and local electrical codes.

Electricity	Description
Power Input	120 ($\pm 10\%$) AC 50-60Hz, 10 Amps
Available Current for accessories	0.5 Amps 24 VAC
Available wire size for incoming power	14 AWG

Section 2c: Installation Specifications

Specification	Measurement	
Minimum Frame Face for Mounting	1-3/4 inches (44mm)	
Minimum Clearance from Top of Door to Ceiling	Bottom Load	Side Load
	6-1/8" (156 mm)	7-18" (181 mm)
Minimum Door Thickness	1-3/4 inches (44 mm)	
Door Width	Specified when ordered	

Section 2d: Base Unit Types

2.d.a: Full Power Swing Doors

- ▶ Utilize Sensor(s) to open a Swing door.
 - Sensors activate the Control by detecting motion of pedestrians (or moving objects) that come into range.
- ▶ Must be compliant with ANSI Standard Code 156.10 to reduce chance of injury to pedestrians and wheeled traffic.

2.d.b: Low Energy Swing Doors

- ▶ Utilize a Knowing Act to open a Swing door.
 - A conscious effort that is carried out in many different ways, including (but not limited to): manually opening/closing a Swing door; pressing various types of Push Plates; turning a Key switch; flipping a Rocker Switch; utilizing a keypad or card reader, etc.
- ▶ Must be compliant with the ANSI Standard Code 156.19 to reduce chance of injury to pedestrians and wheeled traffic.

DANGER

Always remove the bottom portion of the HandiCap Label stating "Push Door To Operate" if the "Push-n-Go" feature is not being used.

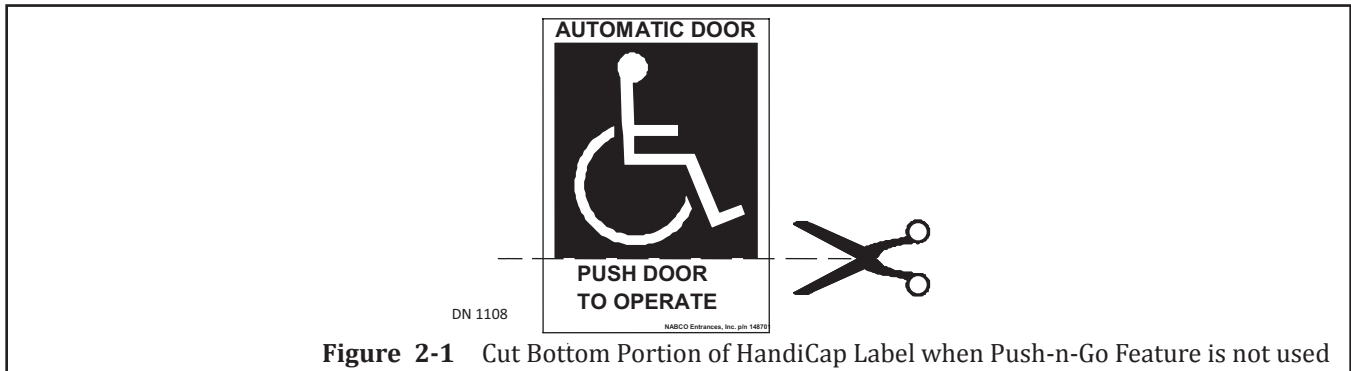

Section 2e: Header Types

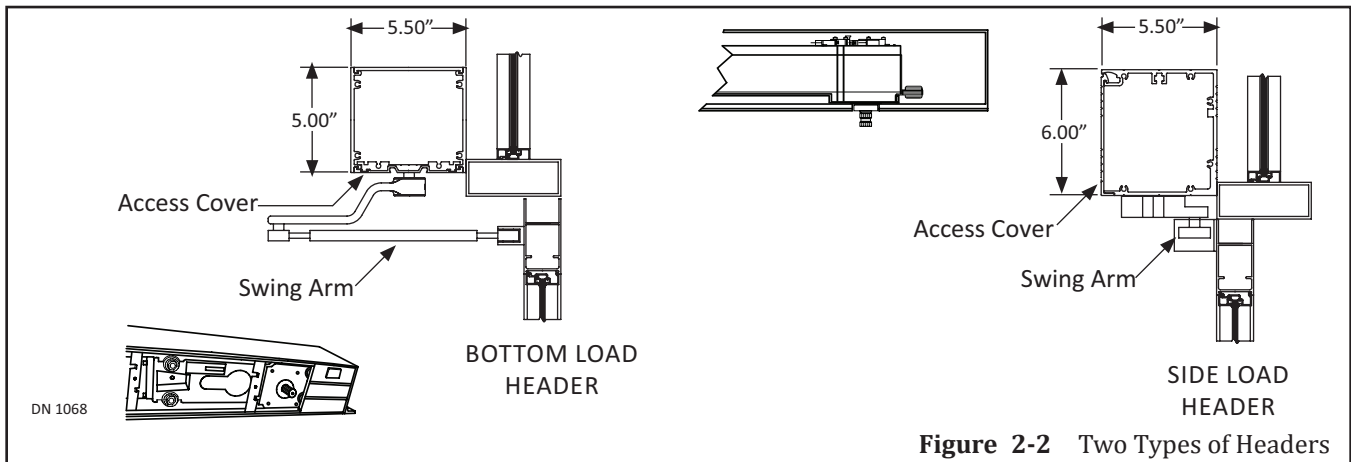

Section 2f: How to Determine Handing

- ▶ To Determine Handing from the Operator: locate the Serial Number underneath Operator. Please see Figure 2-3.
 - a. The Letter (L) or (R) located in front of the Serial Number indicates the Handing.

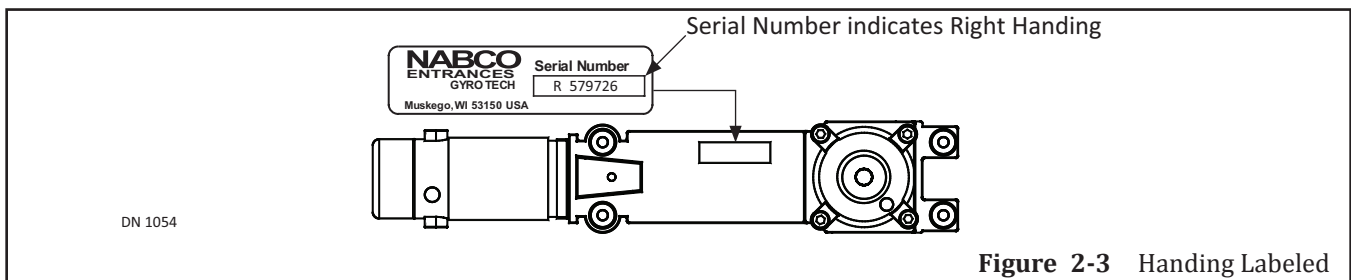

- ▶ To determine Handing from standing underneath the Header: Open the Swing door. Butt your back against the Pivot side of Swing door. Swing out the (right or left) arm in the direction the Swing door opened. Please see Figure 2-4.

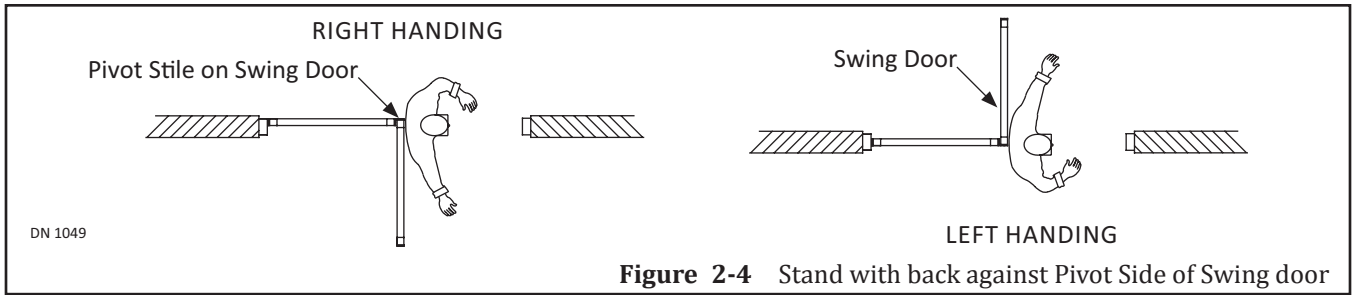

Figure 2-4 Stand with back against Pivot Side of Swing door

► To determine Handing from the direction the Swing Arm opens. Please see Figure 2-5.

- a. If the Swing Arm swings underneath the Threshold to open, it is an Outswing Unit.
- b. If the Swing Arm does not swing underneath the Threshold to open, it is an Inswing Unit.

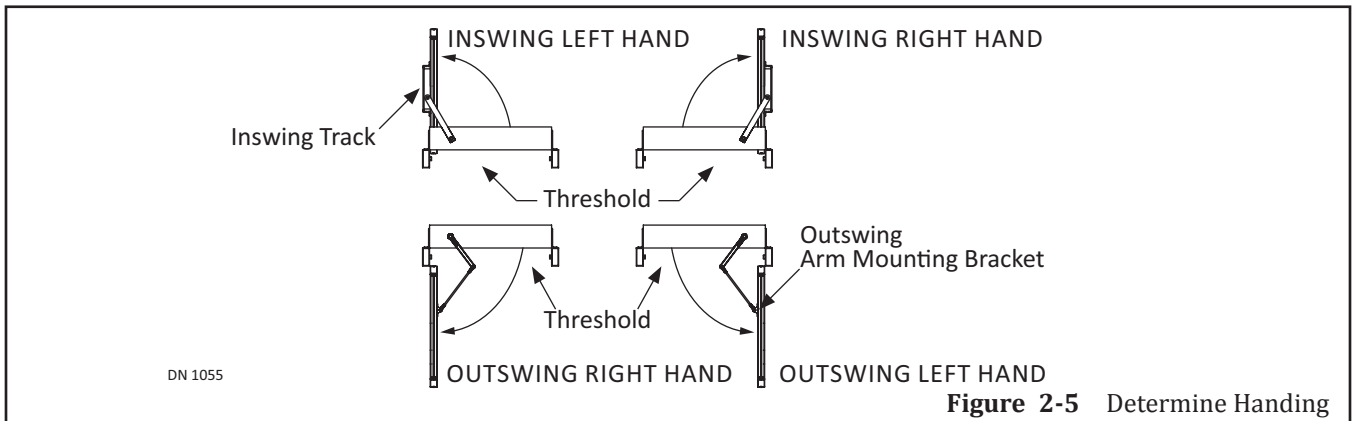
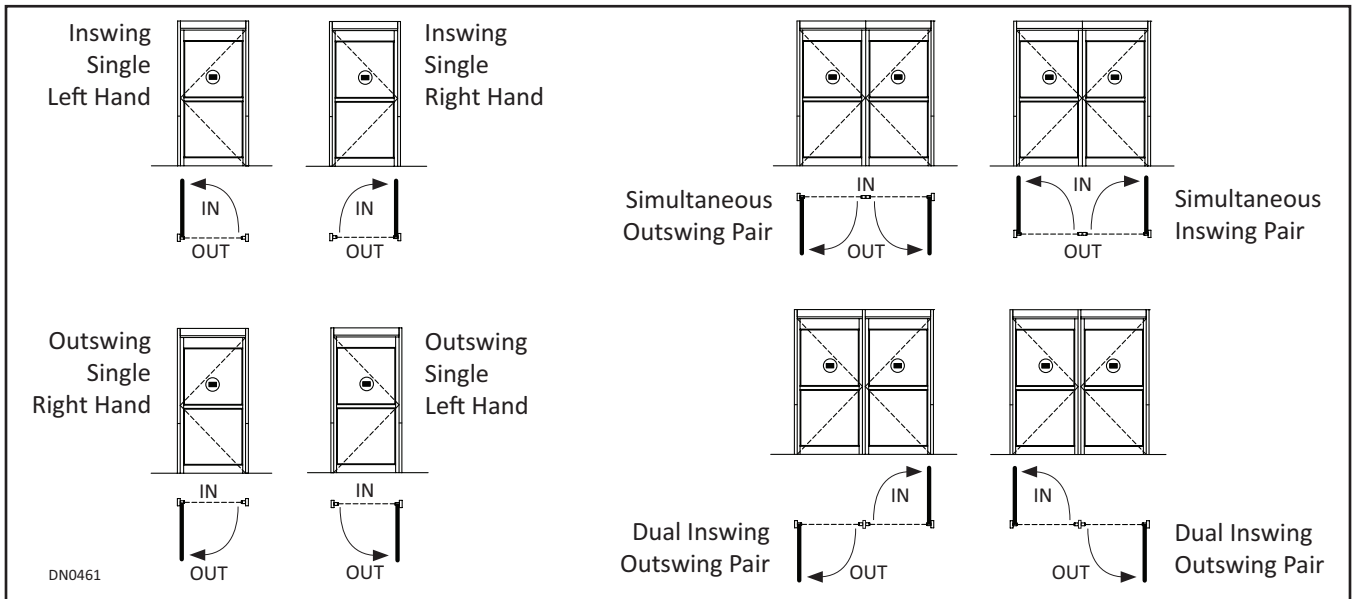

Figure 2-5 Determine Handing

Section 2g: Swing Door Types



Section 2h: Control Types

The Control is programmed to open/close the Swing door according to how the door will be used in terms of Handing, Speed, Time Delay, Back Check, and Latch Check. Two types of Controls can be purchased for the CU Series Swing doors:

- ▶ Magnum 4A
- ▶ Analog Control

Section 2i: Associated Manuals Part Numbers

- ▶ Magnum 4A Control Wiring and Adjustment Manual ;P/N 15-10682
- ▶ Analog Control Wiring and Adjustment Manual; P/N 15-10745
- ▶ Main Power Connection Side Load; P/N 15-12544-10
- ▶ Main Power Connection Bottom Load; P/N 15-12544-20
- ▶ Panic Breakout Latch Wiring Installation Instructions Manual; P/N 15-4572
- ▶ GT400-500-600-8400-8500-8600 Swing Door C.U. QSPG; P/N 15-12499-004

CHAPTER 3: INSTALL THE BOTTOM LOAD HEADER

FOR SIDE LOAD UNITS SKIP TO CHAPTER 5

Section 3a: Prepare the Header

1. Place the Header on flat surface with Bottom facing up.
 - a. Protect Header from scratches.
2. Remove #10-24 x 3/4 inch screws and Dress Plate. Set aside. Please see Figure 3-1.
3. Mark the locations of each Lock Cover Plate to ensure it is reinstalled in the correct position.
4. Remove Lock Cover Plates. Set Aside.
5. Remove boxes and/or parts bags from inside Header. Set aside.

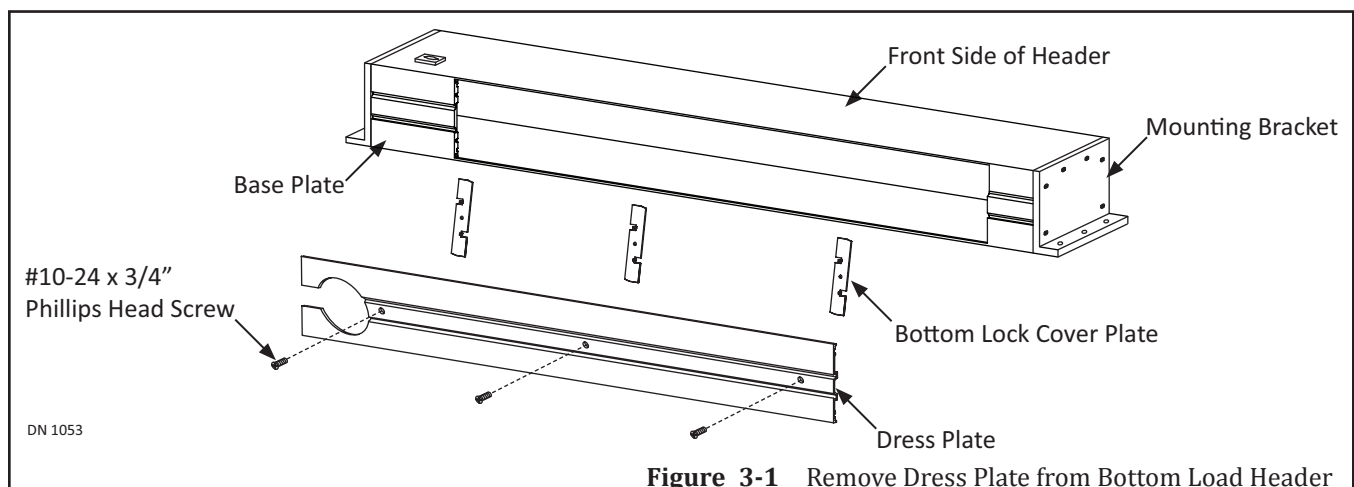

Figure 3-1 Remove Dress Plate from Bottom Load Header

Section 3b: Prepare the Door Frame

Note: The following instructions are for typical Metal Doors and Frame Profile. It is recommended to use lag bolts.

Note: If the Door Frame is not properly reinforced nor anchored to the building surface, and/or is hollow, reinforce the Door Frame with 1/4-20 blind rivnuts (not provided by NABCO).

Note: If the Door Frame is not Metal, ensure the Door Frame being used is of equal strength.

1. Go to the Pivot Side of Swing door.
2. Measure 1-1/8 inch from the Top of Swing door to the Top door frame.
3. Mark a Horizontal Line on the face of Top door frame, at both ends. Please see Figure 3-2.

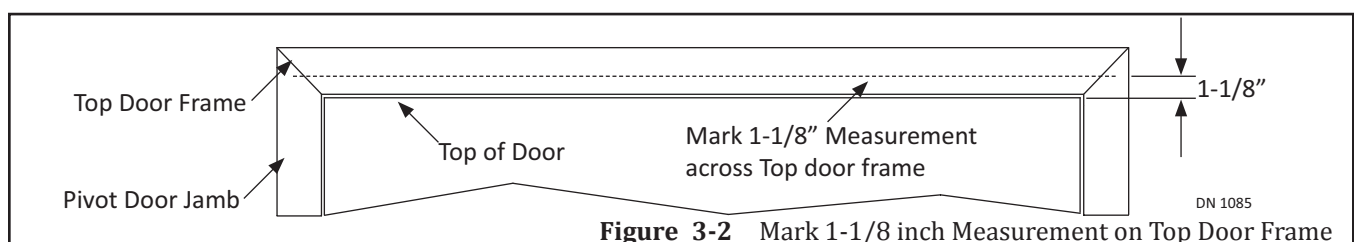
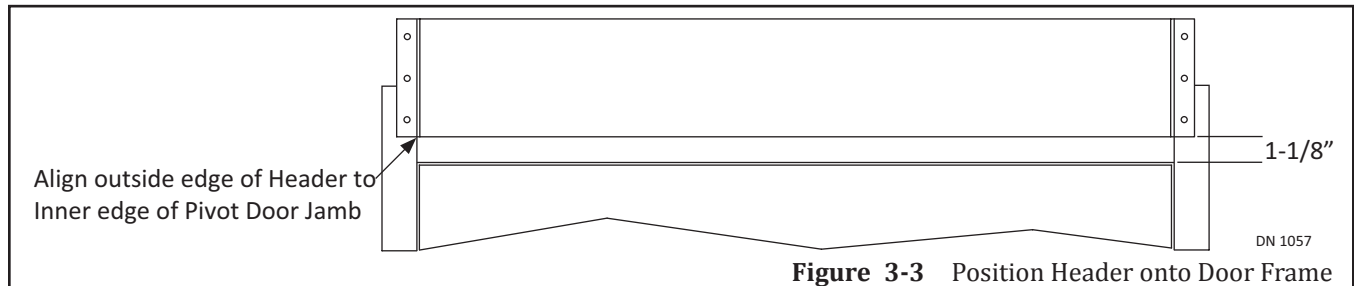

Figure 3-2 Mark 1-1/8 inch Measurement on Top Door Frame

4. Lift the Header up against the Top door frame until the bottom edge of Header is butted up against the Horizontal Line, at both ends. Please see Figure 3-3.
5. To ensure proper operation of the Swing Arm:
 - ▶ For a Door Jamb that is 1-3/4 inches wide, position the Pivot side of Header so it is flush to the outside edge of the Pivot Door Jamb.
 - ▶ For a Door Jamb that is wider than 1-3/4 inches, measure from the inner edge of the Pivot Door Jamb to the center. Mark a vertical line at the 1-3/4 inch measurement. The Pivot side of Header must butt against the 1-3/4 inch mark.



6. Ensure the Header is square and level.
7. Use the Header as a template to mark screw holes onto the face of the door frame.
8. Remove the Header. Set Aside.

Section 3c: Install Shim behind Header (Only if deemed necessary)

FOR UNITS NOT INSTALLING A SHIM SKIP TO SECTION 3D

1. Butt the Header up against the Horizontal line, line up the screw holes and then ensure the Header is square and level.
2. Go to the top of Header. Mark a horizontal line along the top edge of Header and the wall. Please see Figure 3-4.
3. Measure the depth between the back side of the Header and wall.
 - a. Write that measurement down and label it #1.
4. Measure the distance between the top of the door frame and the horizontal line that was just drawn at the top of Header.
 - a. Write that measurement down and label it #2.

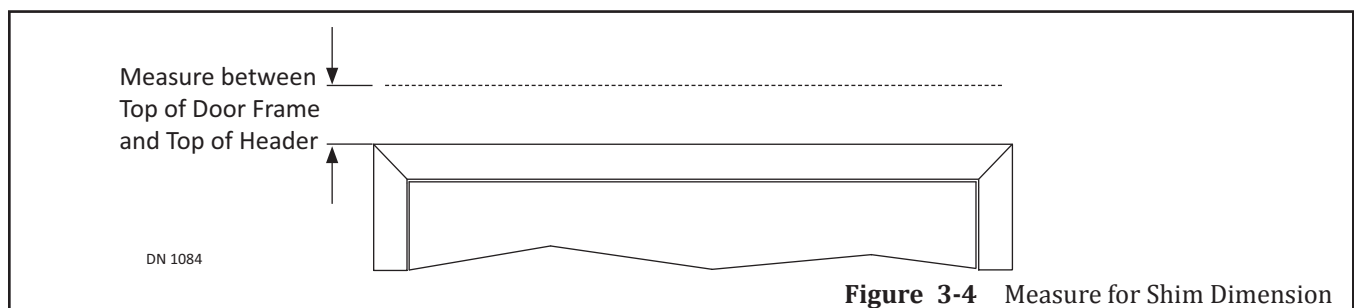

5. Obtain (1) Shim to be the same depth as measurement #1; no higher than measurement #2; and about the same width of Header including Brackets.
 - a. It is recommended to use a Shim made from Fir or Spruce.
 - b. Three Shims can be used as long as each Shim is approximately the same width and height of each Bracket.
6. Secure the Shim to stud(s). Please see Figure 3-5.
 - a. It is recommended to use Lag Bolts.

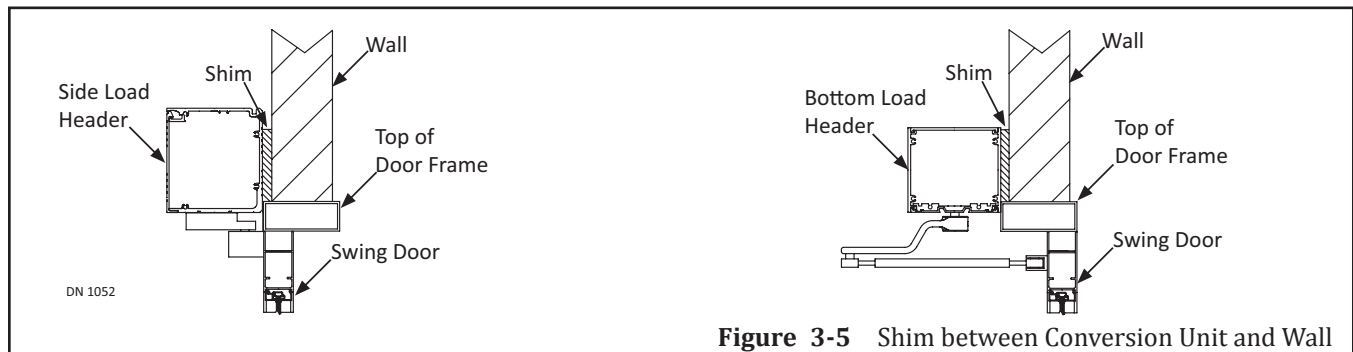

Figure 3-5 Shim between Conversion Unit and Wall

Section 3d: Secure Header to the Door Frame

1. Lift up Header to insert Power Wiring through the 7/8 inch hole.
 - a. It is recommended to use a Conduit.
 - b. It is recommended to insert all other Wiring through a separate hole.
2. Butt the bottom edge of Header against the 1-1/8 inch Horizontal Line.
3. Line up the screw holes.
4. Secure the Header to the Door Frame. Please see Figure 3-6.
 - a. It is recommended to use Lag Bolts.
 - b. For additional mounting, secure the Header to the Stud(s) located behind the Shim.

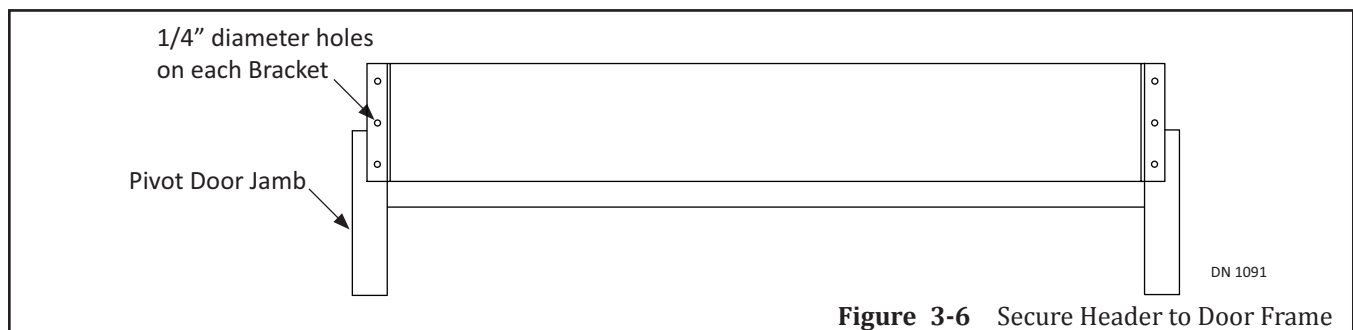

Figure 3-6 Secure Header to Door Frame

CHAPTER 4: INSTALL BOTTOM LOAD COMPONENTS

FOR SIDE LOAD UNITS SKIP TO CHAPTER 5

Note: Location of Contents within Header are subject to change according to Swing door specifications.

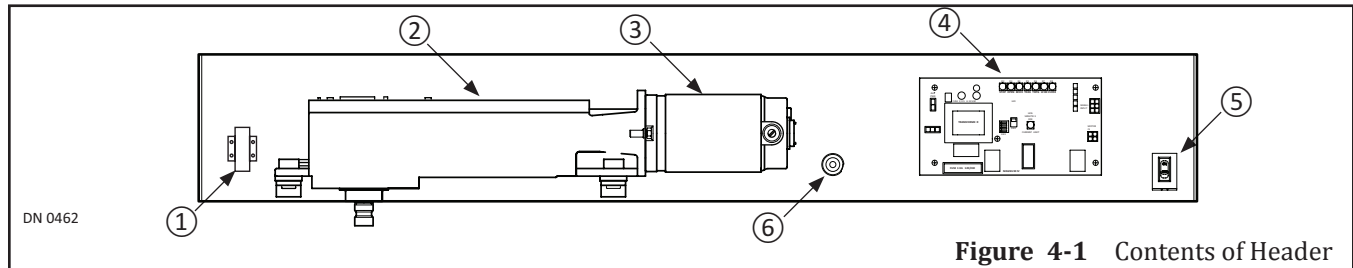

Figure 4-1 Contents of Header

- | | |
|---------------------------|------------------|
| 1. Transformer (Optional) | 4. Control |
| 2. Operator | 5. Rocker Switch |
| 3. Motor | 6. Ground Screw |

Section 4a: Secure Incoming Wires

1. Obtain (self sticking) white plastic Wire Clips provided by NABCO.
2. Adhere each Wire Clip to sides of Header. Insert wiring (as deemed necessary). Please see Figure 4-2.
 - a. 120 VAC Power wires must be routed separate from other wiring, adhere those Wire Clips inside the Header, near the top to prevent pinching.

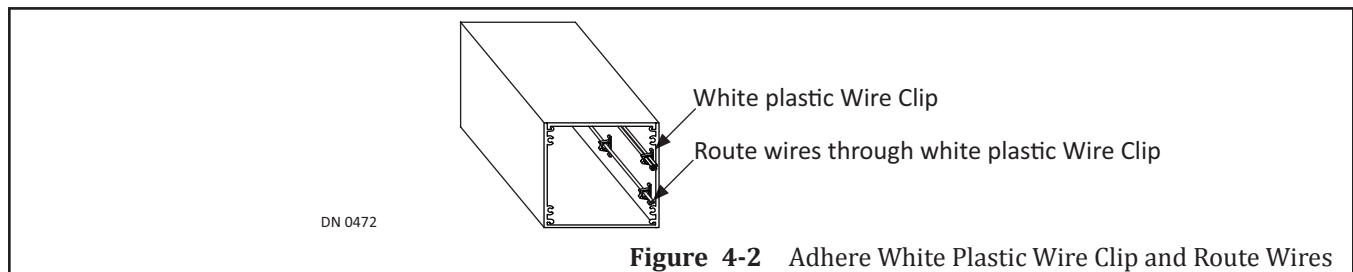

Figure 4-2 Adhere White Plastic Wire Clip and Route Wires

Section 4b: Install the Stop Ring

1. Place the Motor/Operator on a flat surface with the underside facing up. Please see Figure 4-3.
2. Obtain the Stop Ring Assembly provided by NABCO.
3. Slide the Limit Stop onto the Spindle.
4. Secure (4) Ring Stops onto the Limit Stop with 5/16-18 Socket Head screws.
 - a. Do not fully tighten at this time.
5. Once the Swing Arm is fully installed and Pre-Load has been tested:
 1. Open the Swing door 90 degrees.
 2. Rotate the Limit Stop Spindle until it hits the Swing Arm.
 3. Tighten down (4) Ring Stops with 5/16-18 Socket Head screws.

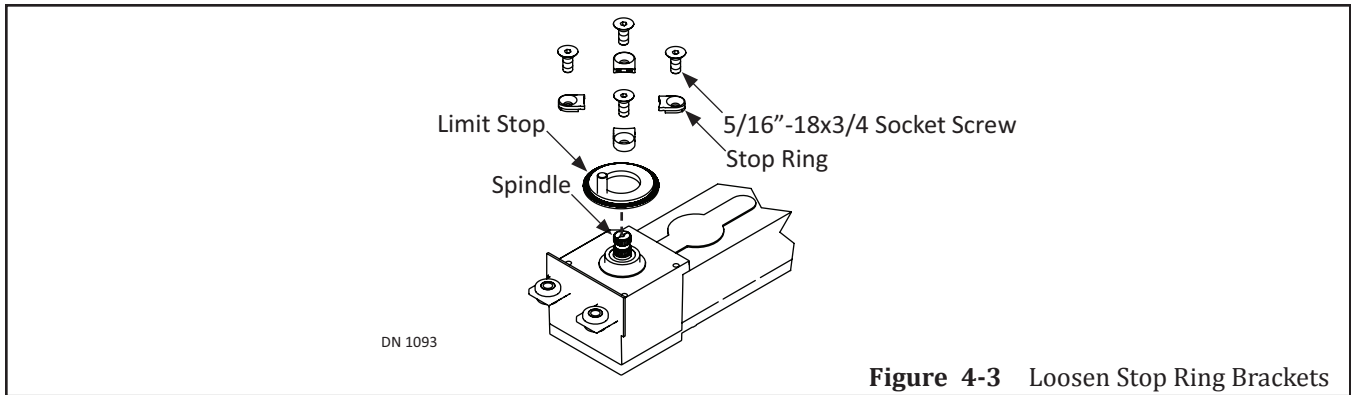

Figure 4-3 Loosen Stop Ring Brackets

Section 4c: Install the Motor/Operator

Table 4-1 Dimension "A" Spindle Location

Bottom Load Units	Pivot Type	Inswing				Outswing			
		With Fingerguard Spindle Loc.	No Fingerguard Base Plate	No Fingerguard Spindle Loc.	No Fingerguard Base Plate	With Fingerguard Spindle Loc.	With Fingerguard Base Plate	No Fingerguard Spindle Loc.	No Fingerguard Base Plate
GT 400	Butt/Offset	N/A	N/A	5"	2-1/2"	N/A	N/A	7-1/4"	4-3/4"
	Center Pivot	6"	3-1/2"	5"	2-1/2"	8-1/4"	5-3/4"	7-1/4"	4-3/4"
GT 500	Butt/Offset	N/A	N/A	5"	2-1/2"	N/A	N/A	5"	2-1/2"
	Center Pivot	6"	3-1/2"	5"	2-1/2"	6"	3-1/2"	5"	2-1/2"

1. Go to Table 4-1 to determine the distance from the center of the Operator Spindle to the Center Pivot or the inside edge of the Pivot Door Jamb.

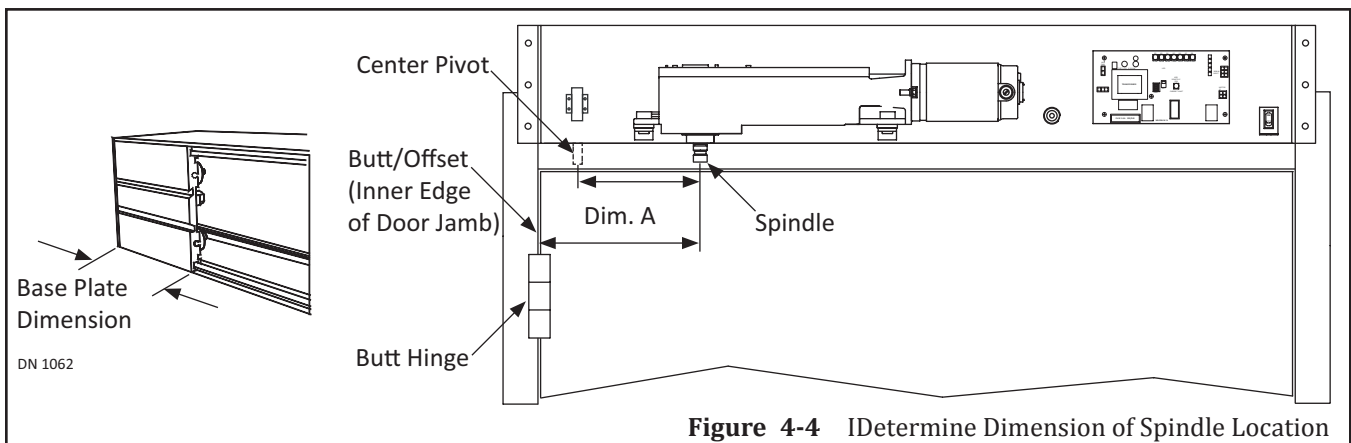

Figure 4-4 Determine Dimension of Spindle Location

2. Go to (inside) top of Header. Please see Figure 4-5.
3. Locate the factory installed Rear Mount Bracket at the top of Header.
4. With a 9/16 inch Deep Well Socket and Ratchet, remove (2) 3/8-16 inch Hex Jam Nuts and (2) 7/16 x 1 inch Washers from (2) Studs extending downward. Set aside.
5. Hold the Front end of Motor/Operator at an upward angle to slide Front Mount onto (2) Pivot Base Tabs located inside of Header.

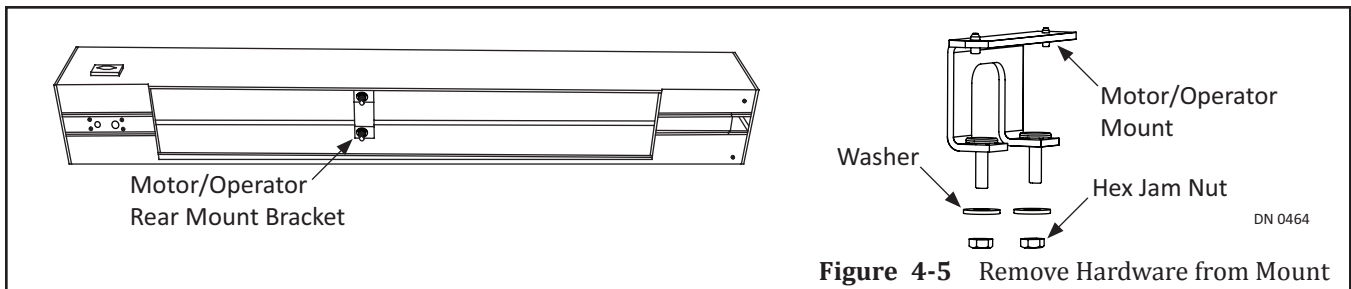

Figure 4-5 Remove Hardware from Mount

6. Lift the rear of the Motor Operator up onto (2) studs extending downward. Please see Figure 4-6.
 - a. Ensure the Switch Harness is tucked between the back wall of Header and above the Mounting Bracket.
7. Secure the Motor/Operator with (2) 3/8-16 inch Hex Jam Nuts and (2) 7/16 x 1 inch Washers.
 - a. It is important not to pinch any wiring during the Motor/Operator installation.

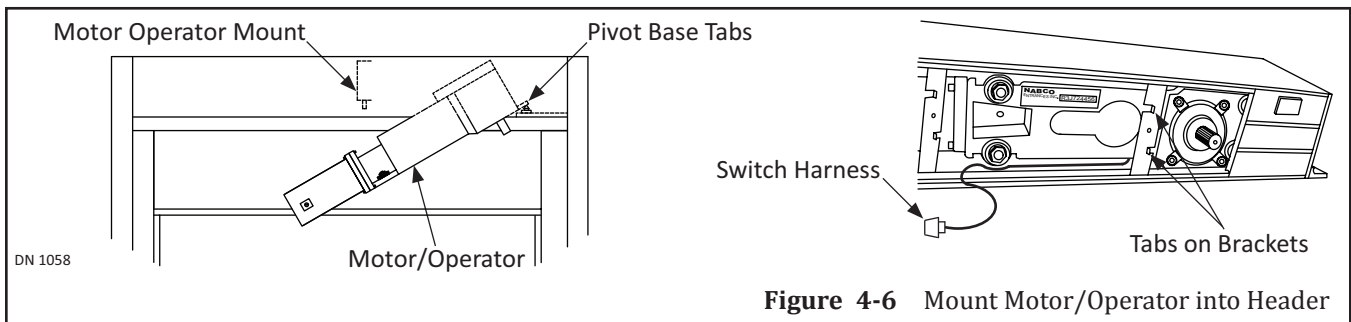

Figure 4-6 Mount Motor/Operator into Header

Section 4d: Install the Control

Note: It may be necessary to mount a Soft Starter Capacitor on the Operator prior to installing the Analog Control. For detailed information, please refer to the "Analog Control Wiring and Adjustment Manual; P/N 15-10745".

1. Obtain the Bracket Clip. Please see Figure 4-7.
2. Go approximately 4-5 inches away from where the Motor/Operator will be installed.
3. Squeeze (2) open ends of the Bracket Clip together until both protruding channels are successfully snapped inside each recessed channel.

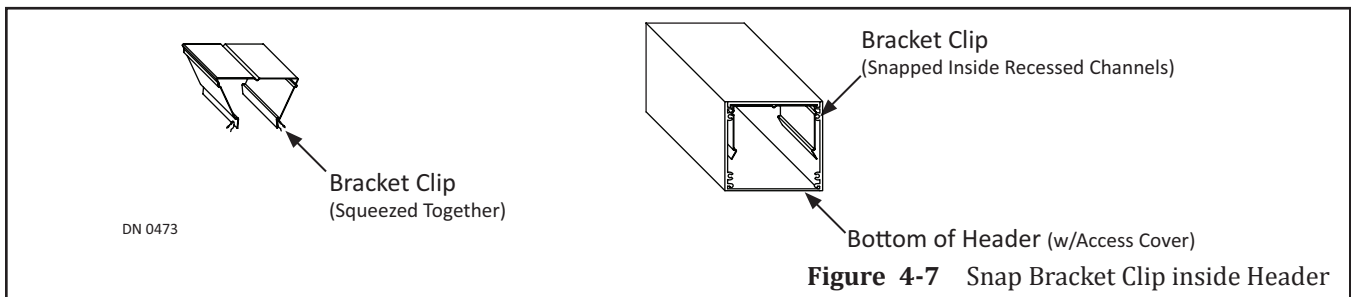
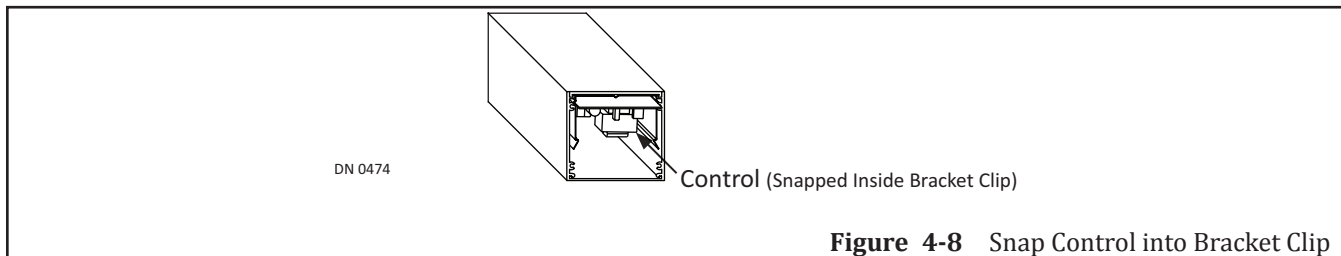

Figure 4-7 Snap Bracket Clip inside Header

4. Snap the Control inside the Bracket Clip. Please see Figure 4-8.
 - a. Face of Control must face down (towards bottom opening of Header).



Section 4e: Install Optional Components

Install all other optional components by following installation and wiring instructions provided with each Component.

CHAPTER 5: INSTALL THE SIDE LOAD HEADER

FOR BOTTOM LOAD UNITS SKIP TO CHAPTER 6

Section 5a: Inswing Doors

FOR OUTSWING UNITS SKIP TO SECTION 5B

1. Open the Swing door 90 degrees.
2. Measure between the wall and the outside face of the Swing door.
 - a. There must be a 2 inch minimum gap for the Inswing Arm to operate properly.
 - b. If there is less than a 2 inch gap, please call Customer Service at (877) 622-2694.

Section 5b: Prepare the Header

Note: It may be necessary to remove the Motor/Operator from the Header to reduce weight, while positioning the Header onto the Door Frame.

3. Place the Header on flat surface with Side facing up.
 - a. Protect header from scratches.
4. Remove two screws from underneath cover. Set Aside.
5. Remove Cover by lifting it up from Header, and then pulling it out. Please see Figure 5-1.
6. Remove boxes and/or parts bags from inside Header. Set aside.

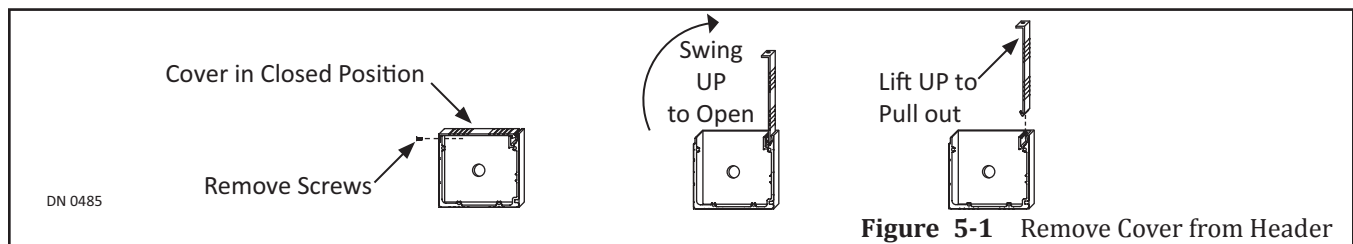

Figure 5-1 Remove Cover from Header

5.b.a: Drill Holes

1. Go to the Strike side of Header. Drill one 7/8 inch hole through the Header to allow all wiring to be drawn inside.
 - a. The Side Load Header can be ordered with a Knockout hole located at either end of the Header. For details, please call Customer Service at 1-888-679-3319.
2. Go to the back wall inside Header on the Pivot side. Please see Figure 5-2.
3. Measure 1 inch from the End Cap of Header towards the center. Mark a Vertical Line.
4. Measure at least 1/2 inch from the bottom of Header towards the top. Mark a Horizontal Line across the Vertical line. This is the center of the first screw hole. Drill 1/4 inch screw hole.
5. Mark (1) more Horizontal line across the Vertical line directly above the first screw hole. This is the center of the second screw hole. Drill 1/4 inch screw hole.
 - a. It may be necessary to install a Shim behind the Header if mounting the Header to a wall.
6. Go to the Strike side of Header. Repeat steps 3 thru 5.

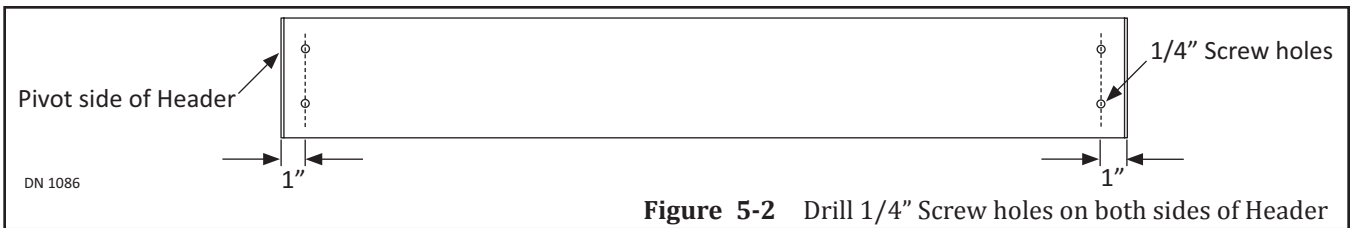

Figure 5-2 Drill 1/4" Screw holes on both sides of Header

Section 5c: Prepare the Door Frame

Note: The following instructions are for typical Metal Doors and Frame Profile. It is recommended to use lag bolts.

Note: If the Door Frame is not properly reinforced nor anchored to the building surface, and/or is hollow, reinforce the Door Frame with 1/4-20 blind rivnuts (not provided by NABCO).

Note: If the Door Frame is not Metal, ensure the Door Frame being used is of equal strength.

1. Go to the Pivot Side of Swing door.
2. Measure 1-1/8 inch from the Top of Swing door to the Top door frame.
3. Mark a Horizontal Line on the face of the Top door frame, at both ends. Please see Figure 5-3.

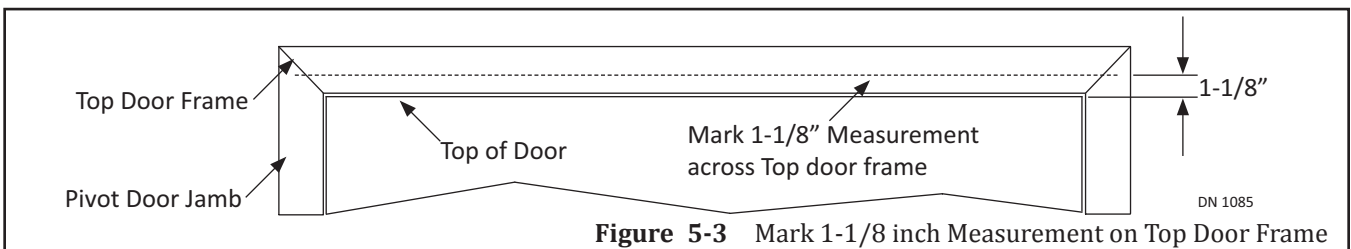

Figure 5-3 Mark 1-1/8 inch Measurement on Top Door Frame

4. Lift the Header up against the Top door frame until the bottom edge of Header is butted up against the Horizontal Line, at both ends. Please see Figure 5-4.
5. To ensure proper operation of the Swing Arm:
 - ▶ For a Door Jamb that is 1-3/4 inches wide, position the Pivot side of Header so it is flush to the outside edge of the Pivot Door Jamb.
 - ▶ For a Door Jamb that is wider than 1-3/4 inches, measure from the inner edge of the Pivot Door Jamb to the center. Mark a vertical line at the 1-3/4 inch measurement. The Pivot side of Header must butt against the 1-3/4 inch mark.

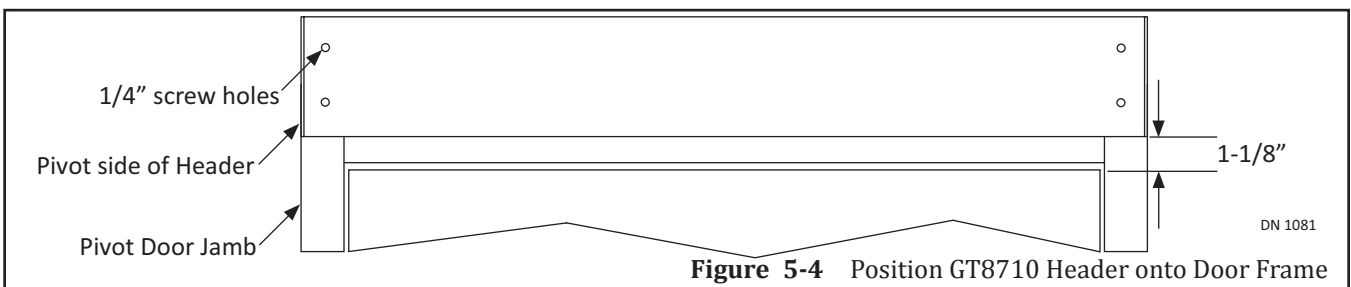

Figure 5-4 Position GT8710 Header onto Door Frame

6. Ensure the Header is square and level.
7. Use the Header as a template to mark screw holes onto the face of the door frame.
8. Remove the Header. Set Aside.

Section 5d: Install Shim (Only if deemed necessary)

FOR UNITS NOT INSTALLING A SHIM SKIP TO SECTION 5E

1. Butt the Header up against the Horizontal line, line up the screw holes and then ensure the Header is square and level.
2. Go to the top of Header. Mark a horizontal line along the top edge of Header and the wall.
3. Measure the depth between the back wall of the Header and the wall
 - a. Write that measurement down and label it #1.
4. Measure the distance between the top of door frame and the horizontal line that was just drawn at the top of Header. Please see Figure 5-5.
 - a. Write that measurement down and label it #2.

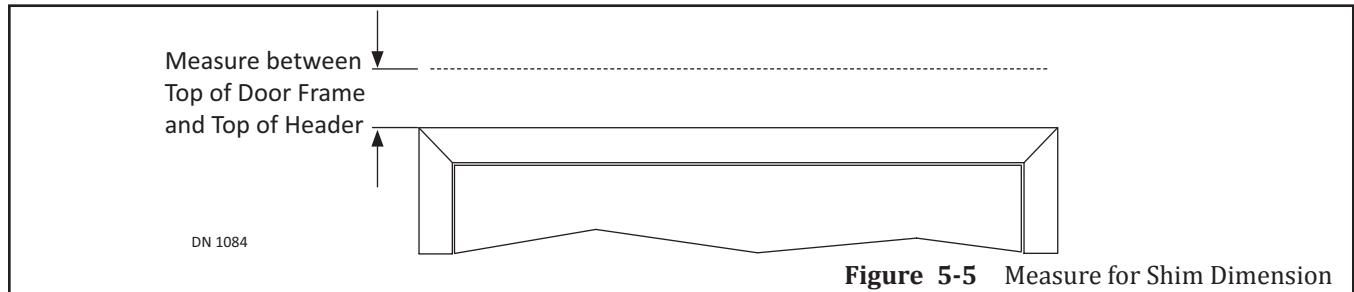

5. Obtain (1) Shim to be the same depth as measurement #1; no higher than measurement #2; and about the same width as the Header.
 - a. It is recommended to use a Shim made from Fir or Spruce.
6. Secure the Shim to stud(s). Please see Figure 5-6.
 - a. It is recommended to use Lag Bolts.

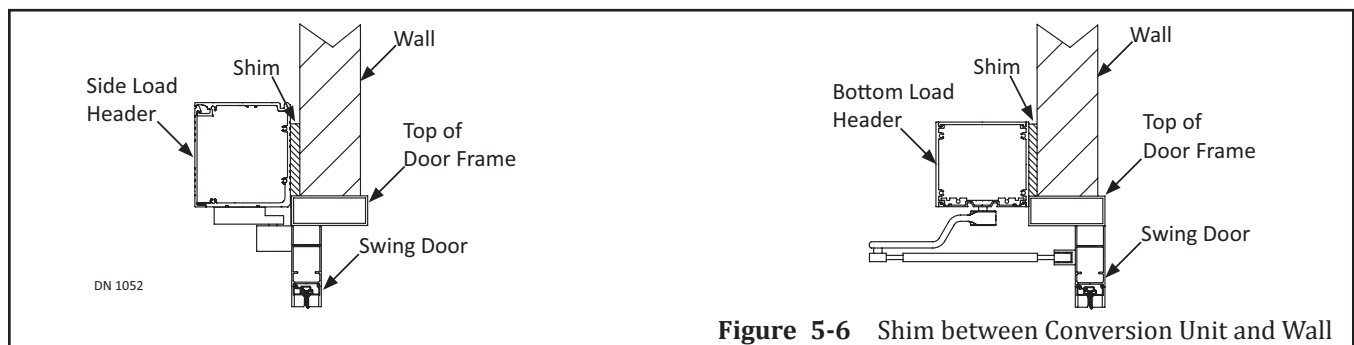

Section 5e: Secure Header to the Door Frame

1. Lift up the Header to insert Power Wiring through the 7/8 inch hole.
 - a. It is recommended to use a Conduit.
 - b. It is recommended to insert all other Wiring through a separate hole..
2. Secure the Header to the Door Frame. Please see Figure 5-4.
 - a. It is recommended to use Lag Bolts.
 - b. For additional mounting, secure the Header to the Studs located behind the Shim.

CHAPTER 6: 110 VAC GENERAL WIRING

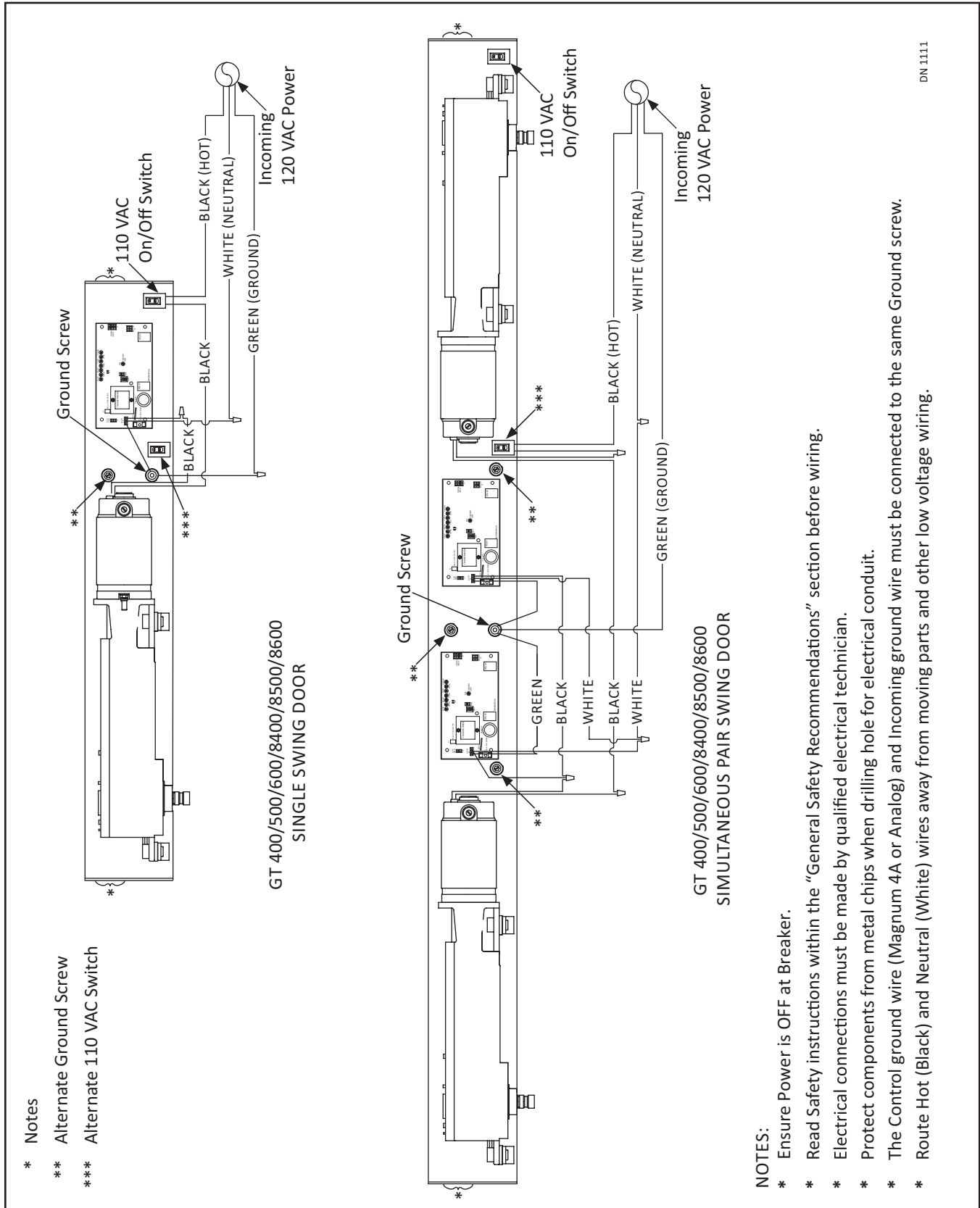

CHAPTER 7: INSTALL THE FIRST HALF OF SWING ARM

Section 7a: Outswing Arm

FOR INSWING ARMS SKIP TO SECTION 7B

7.a.a: Prep the Swing Door

Table 7-1 Dimension "A" Arm Shoe Mounting Locations

Model	Pivot Type	Outswing	
		With Fingerguard	No Fingerguard
GT 400 & 8400	Butt/Offset	N/A	12-7/16"
	Center Pivot	16"	15"
GT 500 & 8500	Butt/Offset	N/A	10-3/16"
	Center Pivot	13-3/4"	12-3/4"

1. Go to Table 7-1 to measure the distance from the inside edge of the Pivot Door Jamb, or the Center Pivot to the center of the first Sex Bolt hole (used to attach the Arm Shoe).
2. Mark a Vertical line on the face of the Swing door. Please see Figure 7-1.
3. At the Vertical line, measure 1-1/2 inches from the top edge of the Swing door down to the center of the Swing Door.
4. Mark a Horizontal line to cross the Vertical line. This is the center of the first Sex Bolt hole.

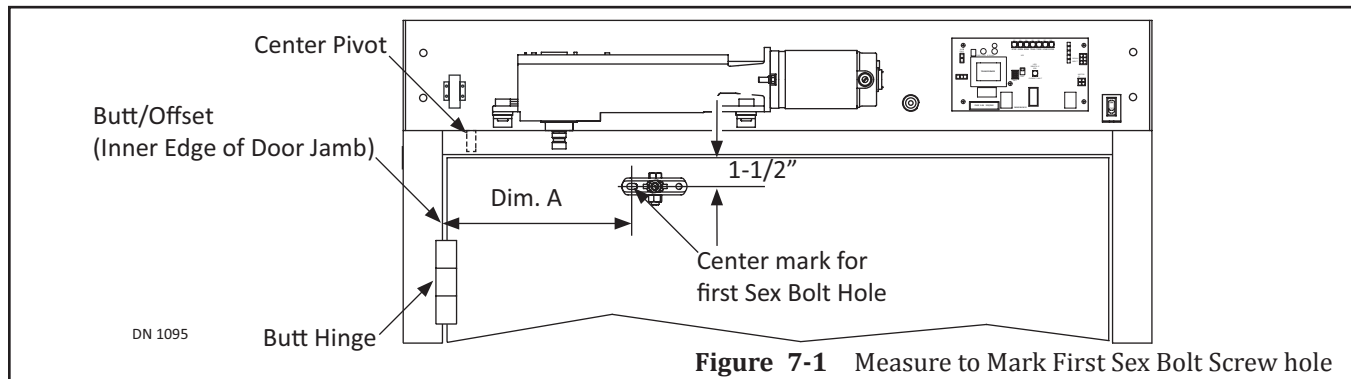

7.a.b: Prep the Outswing Arm Assembly

1. Remove the Outswing Arm from the Threaded Rod. Set aside. Please see Figure 7-2.

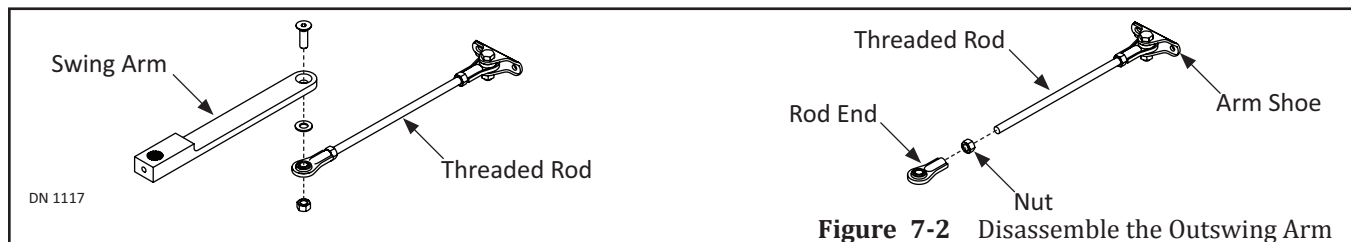

2. Go to Table 7-3 to locate the appropriate length measurement for the Threaded Arm.

Note: For Reveals that are (0 inches thru 6-1/2 inches), a 20 inch Threaded Rod must be purchased. For Reveals that are (6-3/4 inches and higher), a 30 inch Threaded Rod must be purchased.

Table 7-3 Dimension "B" Rod Length

Model	Pivot Type	Reveal					
		1-1/8 inch	2-1/8 inch	3-1/8 inch	4-1/8 inch	5-1/8 inch	6-1/8 inch
GT 400 & 8400	Butt/Offset	11-7/8"	12-7/8"	13-7/8"	14-7/8"	15-7/8"	16-7/8"
	Center Pivot	12-1/2"	13-1/2"	14-1/2"	15-1/2"	16-1/2"	17-1/2"
GT 500 & 8500	Butt/Offset	11-7/8"	12-7/8"	13-7/8"	14-7/8"	15-7/8"	16-7/8"
	Center Pivot	11-7/8"	12-7/8"	13-7/8"	14-7/8"	15-7/8"	16-7/8"

3. Measure the Threaded Rod between the center of each Eye, located on each Eye, Located at each end of the Rod. Please see Dim B in Figure 7-3.
4. Remove the Link that is not attached to the Arm Shoe, from the Threaded Rod.
5. Cut the Threaded Rod according to the measurement that was determined in Step 3.

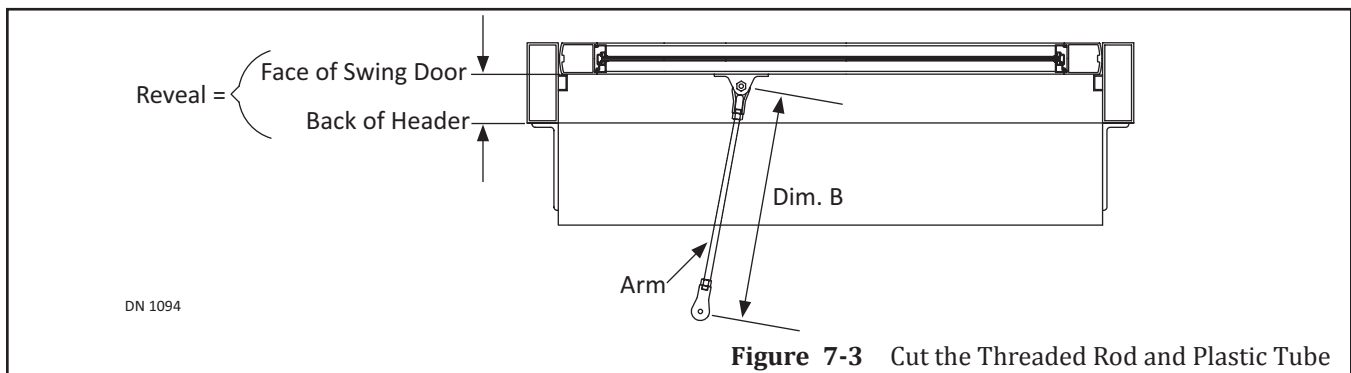

6. Obtain (1) color coordinated Plastic Tube from the Outswing Rod assembly.
7. Cut the Plastic Tube to the same length as the exposed Rod (between the Links and Nuts).
8. Slide the Plastic Tube over the Threaded Rod.
9. Replace the Rod Link back onto the Threaded Rod.
10. Tighten the Nut against the Link to prevent the Rod from screwing In or Out.

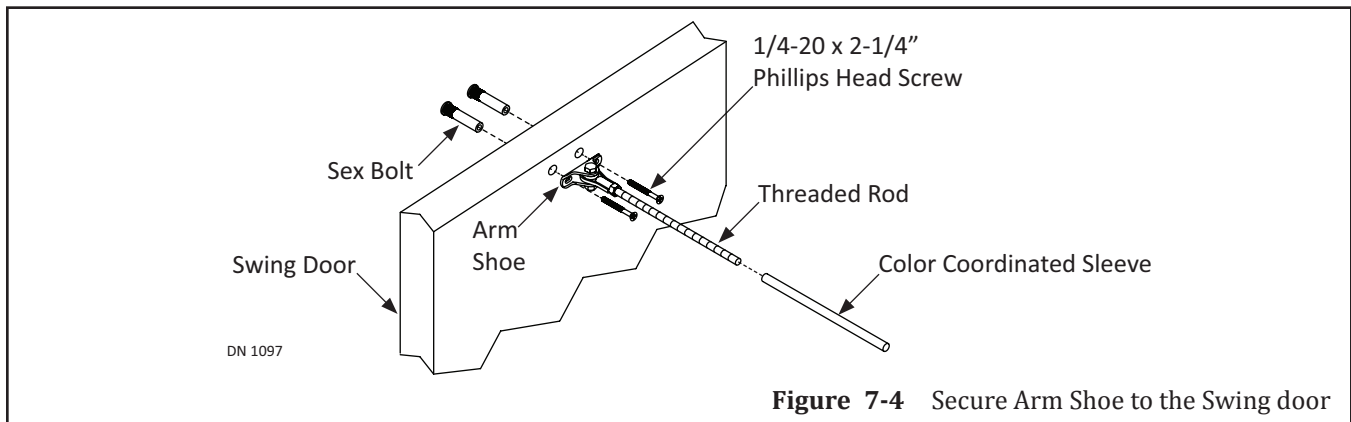

7.a.c: Secure the Arm Shoe to the Swing Door

1. Butt the Arm Shoe against the Swing door. Align the first Sex Bolt hole to the measured Mark.
2. Ensure the Arm Shoe is square and level.
3. Use the Arm Shoe as a Template to mark the second Sex Bolt hole. Set aside.
4. Drill (2) 3/8 inch bolt holes all the way through the Swing door.
5. Go to the back of the Swing door. Insert each Sex Bolt into the drilled holes.
6. Go to the front of the Swing door. Secure the Arm Shoe to the Swing Door with (2) 1/4-20 x 2-1/4" Screws.

Section 7b: Inswing Arm

Note: Ensure there is a 2 inch gap between the wall and the outside face of the Swing door in the fully operated position of 90 degrees, for the Inswing Arm to operate properly.

Table 7-4 Dimension "C" Track Mounting Locations

Model	Pivot Type	Inswing Standard Track (ST) 12-1/4"		Inswing Standard Track (PT) 21"	
		With Fingerguard	No Fingerguard	With Fingerguard	No Fingerguard
GT 400 & 8400	Butt/Offset	N/A	8-1/4"	N/A	N/A
	Center Pivot	13"	12"	3-3/4"	2-3/4"
GT 500 & 8500	Butt/Offset	N/A	8-1/4"	N/A	N/A
	Center Pivot	13-3/4"	12"	3-3/4"	2-3/4"

1. Go to Table 7-4 to measure distance from the inside edge of the Pivot Door Jamb, or the Center Pivot to the center of the first Sex Bolt hole (used to attach the Track).
2. Mark a Vertical line on the face of the Swing door. Please see Figure 7-5.

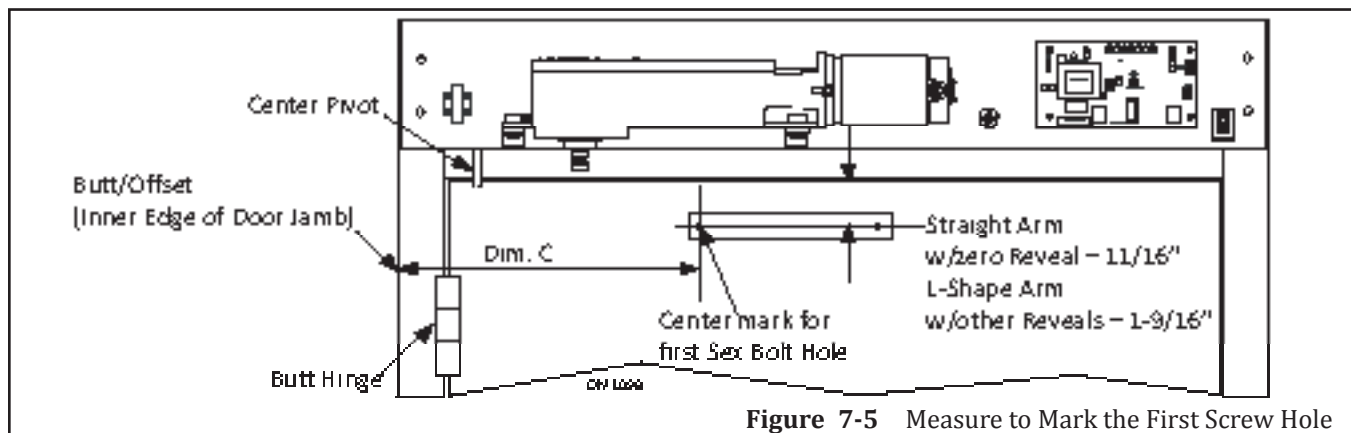
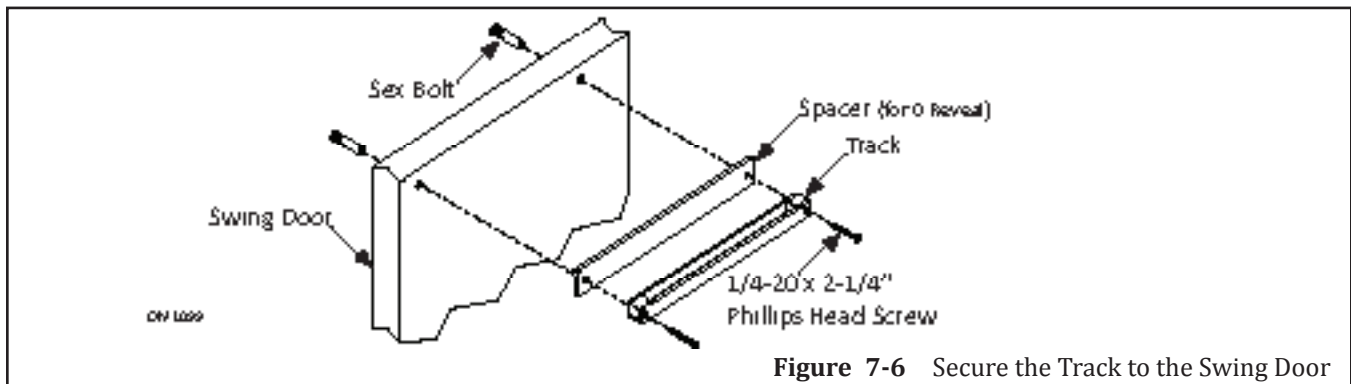

Figure 7-5 Measure to Mark the First Screw Hole

3. Measure:
 - ▶ 0 inch Reveal (Straight Arm): 11/16 inch from the top edge of the Swing Door down to the center of the Swing Door.
 - ▶ Reveals greater than 0 inch (L-Shape Arm): 1-9/16 inch from the top edge of the Swing Door down to the center of the Swing Door.
 - ▶ New dimension not shown (L-Shape Arm): Reveal + 8-7/8 inch = New dimension

4. Mark a Horizontal line to cross the Vertical line. This is the center of the first Sex Bolt hole.
5. Butt the Track against the Swing door by aligning the first Sex Bolt hole with the measured Mark.
6. Ensure the Track is square and level.
7. Use the Track as a Template to mark the second Sex Bolt hole. Set aside.
8. Drill (2) 3/8 inch bolt holes all the way through the Swing door.
9. Go to the back of the Swing door. Insert each Sex Bolt into the drilled holes.
10. Go to the front of the Swing door.
11. Butt the Track against the Swing door by aligning the Sex Bolt holes.
 - a. Install (1) Spacer behind the Track for Swing doors with "0" Reveal.
12. Secure the Track to the Swing Door with (2) 1/4-20 x 2-1/4" Screw. Please see Figure 7-6.



CHAPTER 8: INSTALL THE SECOND HALF OF SWING ARM

Section 8a: Set Pre-Load

WARNING

Proper Preload is critical for the Control and Operator to open/close the Swing Door correctly.

CAUTION

Power must be turned OFF during the Swing Arm installation.

DANGER

Ensure the Motor/Operator is plugged into the Controller.

1. Ensure the Spring on the Operator is in the Unwound (0°) position. Please see Figure 8-1.
 - a. The Motor/Operator is shipped in the Unwound (0°) position.

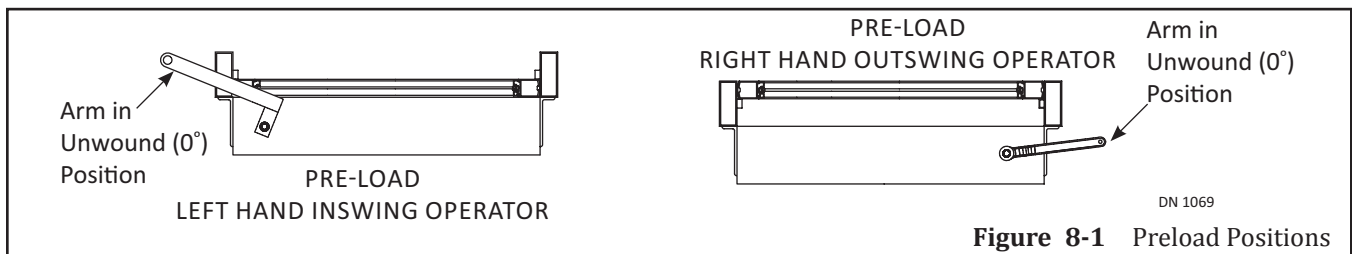

Figure 8-1 Preload Positions

2. Obtain (1) Pin or 1/8 inch Allen Wrench.
3. Go underneath the Header. Locate the Operator Spindle.
4. At the 0 degree position, slide the Swing Arm onto the Spindle.

DANGER

Do not allow the Pin or 1/8 inch Allen Wrench to drop out of the Lovejoy Coupling Access hole at any time during installation. The Swing Arm will spring back to its original location and can result in personal injury or damage.

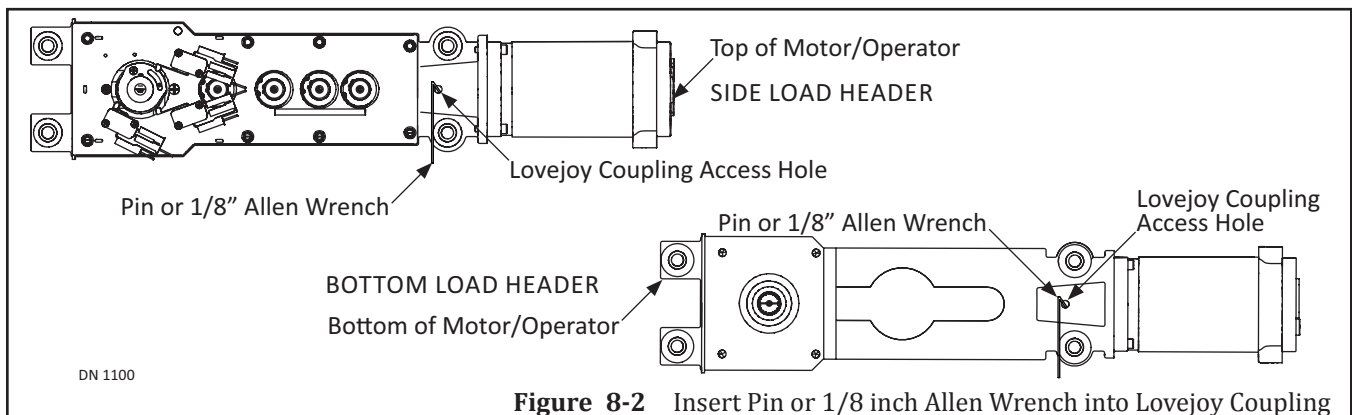
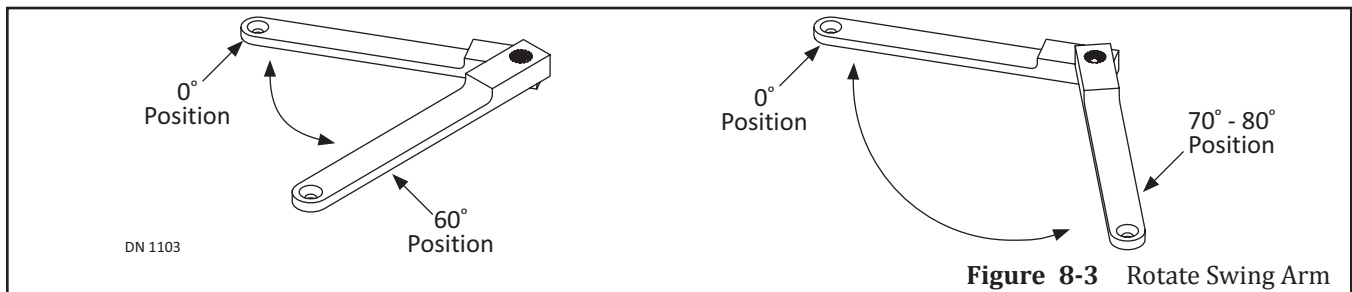

Figure 8-2 Insert Pin or 1/8 inch Allen Wrench into Lovejoy Coupling

5. In order to achieve correct Back Check and Latch Check positions, the Spring on the Operator must be wound up approximately 130 - 140 degrees. With a firm grip, from the Unwound (0 degree) position, rotate the Swing Arm approximately 60 degrees:
 - ▶ Clockwise
 - For Left Handing
 - ▶ Counter-Clockwise
 - For Right Handing

6. While holding the Swing Arm in that position, insert (1) Pin or 1/8 inch Allen Wrench into the Lovejoy Coupling Access Hole. Please see Figure 8-2.
 - a. It may be necessary to ease the Swing Arm back until the Pin or 1/8 inch Allen Wrench engages the Lovejoy Coupling.
7. Remove the Swing Arm from the Operator Spindle.
 - a. The Pin or 1/8 inch Allen Wrench will keep the Spring from unwinding.
8. Go to the 0 degree position again, slide the Swing Arm back onto the Operator Spindle. Please see Figure 8-3.
9. With a firm grip, slightly remove pressure from the Spring to allow removal of the Allen wrench. Continue to rotate the Swing Arm an additional 70-0 degrees. Re-insert the Allen wrench and then remove the Swing Arm.
 - a. The Spring on the Operator should be wound approximately 130 - 140 degrees.



Section 8b: Secure the Swing Arm to the Swing Door

8.b.a: Outswing Arm

1. Align the Screw hole at the end of Swing Arm to the Screw hole at the end of Threaded Rod.
 - a. It may be necessary to remove and then slide the Swing Arm back onto the Operator Spindle.
2. Secure the Swing Arm to the Threaded Rod with (1) 3/8"-24 x 1-1/4" Socket Screw, (1) .405 Washer, and (1) 3/8"-24 Lock Nut.

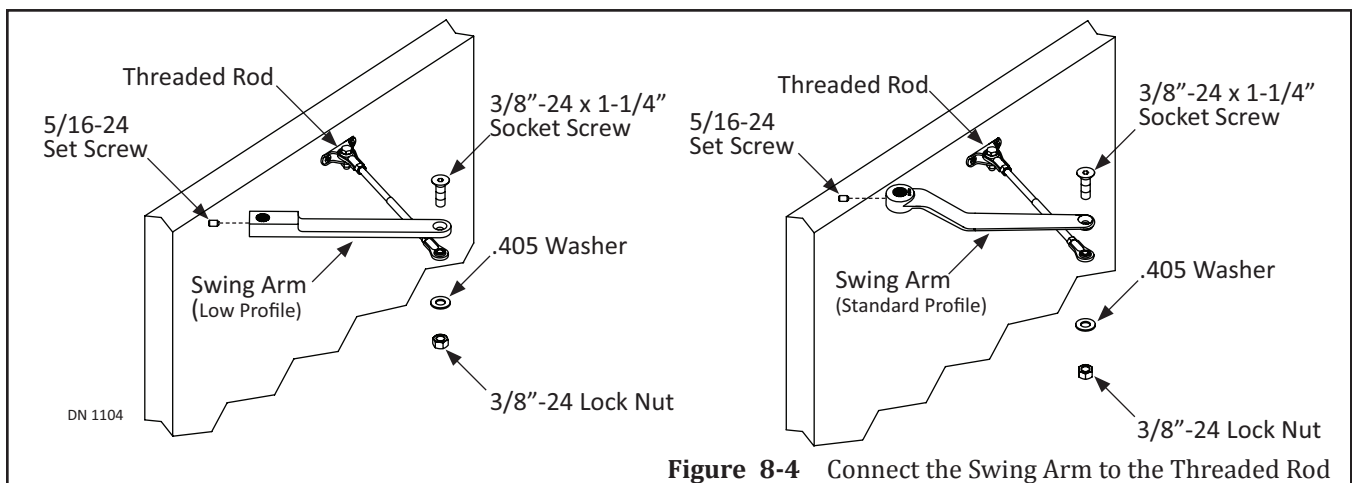

8.b.b: Inswing Arm

1. Go to the first 1/4-20 x 2-1/4" Screw (closest to the Pivot Door Jamb) that is used to secure the Track to the Swing door.
2. Remove the first 1/4-20 x 2-1/4" Screw so that side of the Track will hang down.
3. Close the Swing door to allow the Wheeled Roller (located at the end of the Swing Arm) to butt against the Swing door.
4. Raise the Track until the screw hole is aligned with the screw hole on the Swing door.
 - a. The Wheeled Roller will insert itself into the Track.
5. Secure the Track to the Swing door with (1) 1/4-20 x 2-1/4" Screw.

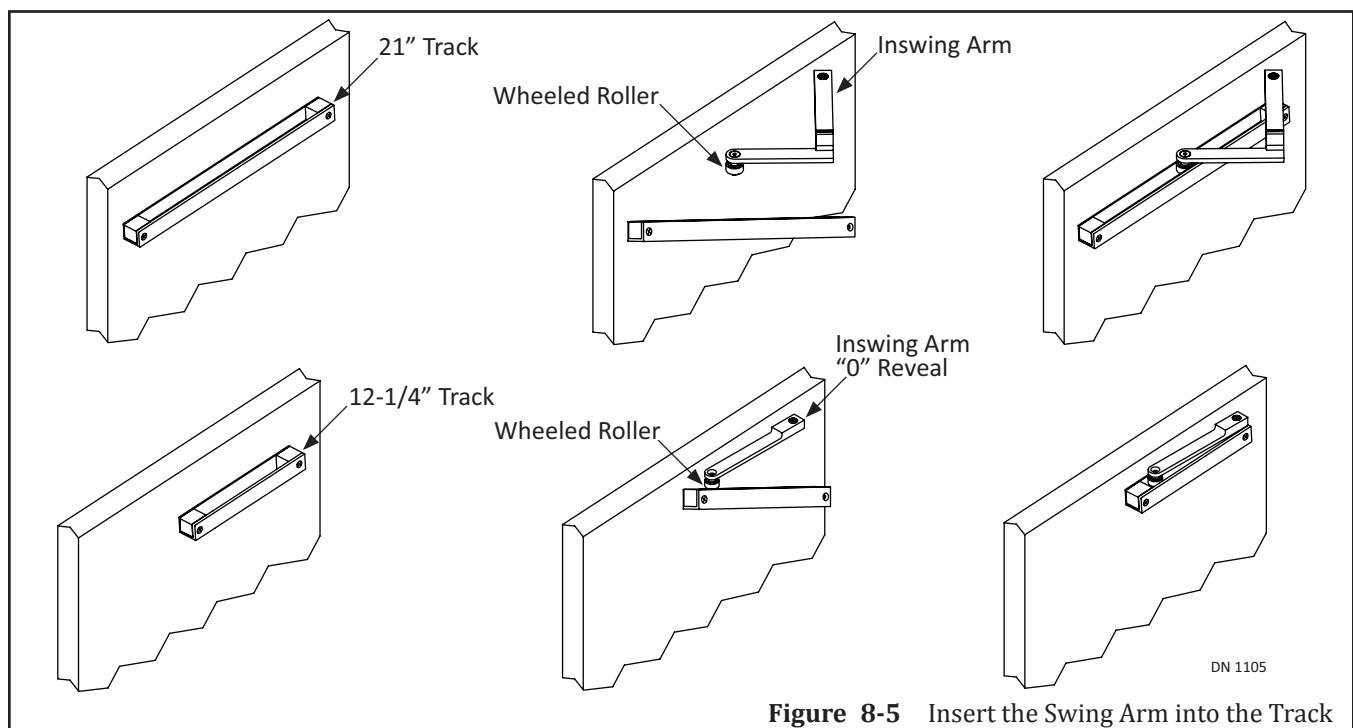
**Figure 8-5** Insert the Swing Arm into the Track**8.b.c: Inspect the Scribe Mark**

1. Fully close the Swing door.
2. Go to the underside of the Operator Spindle. Locate (1) Scribe Mark.
3. Ensure the Scribe Mark is parallel with the Swing Door.

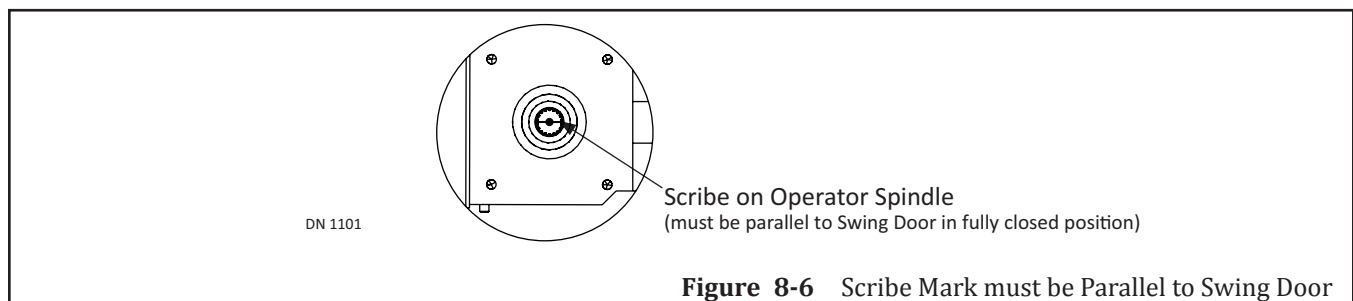
**Figure 8-6** Scribe Mark must be Parallel to Swing Door

8.b.d: Secure the Swing Arm to the Operator Spindle

1. Secure the Swing Arm to the Operator Spindle with (1) Set Screw. Tighten but do not overtighten.
 - a. Ensure the Set Screw is seated correctly within the groove on the Operator Spindle.
2. Remove the Allen Wrench.

Section 8c: Test the Pre-Load

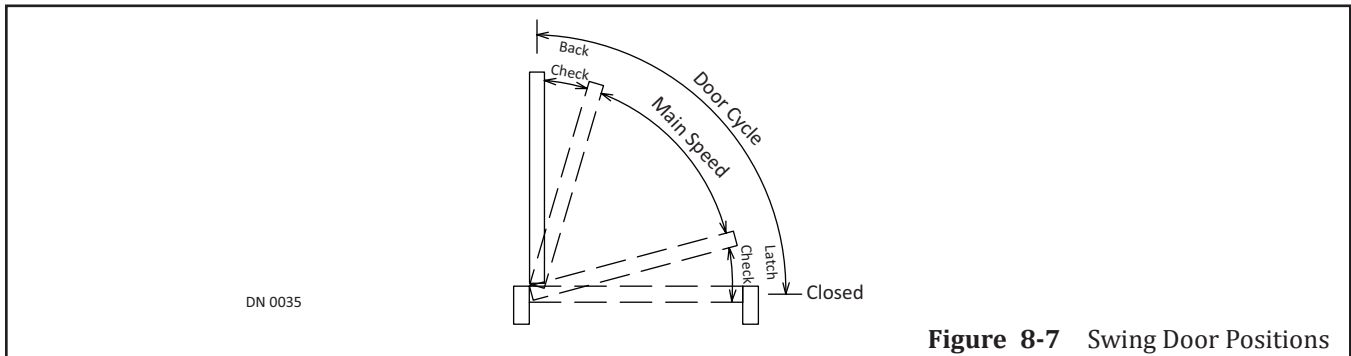

Figure 8-7 Swing Door Positions

Position	Description
Opening	Range from fully closed to 10° from fully open.
Back Check	10° from fully open to fully open.
Closing	Range from fully open to 10° from fully closed.
Latch Check	10° from fully closed to fully closed.

1. Turn Power ON.
2. Open Swing Door.
 - a. Swing door should slow down at 75° - 80° open.
 - b. If Swing door stops at any other degree, Back Check needs to be adjusted.
3. Close Swing Door.
 - a. Swing door should slow down at 75° - 80° close.
 - b. If Swing door slows down at any other degree, Latch Check needs to be adjusted.

Section 8d: Install the Arm Stop (Side Load Units)

***BOTTOM LOAD UNITS SKIP TO
CHAPTER 9***

CAUTION

Do Not drill screw holes for the Arm Stop into the Motor/Operator!!!

1. Open the Swing Door 90 degrees.
2. Obtain the Parts Bag that includes (1) Arm Stop and (2) 1/4-20 inch Self Tapping screws.
3. Position the Arm Stop at the bottom of Header according to type of Swing Arm and Reveal shown in Figure 8-8.

- 4. Use the Arm Stop as a template to mark and drill (2) 7/32 inch diameter screw holes.
- 5. Secure the Arm Stop with (2) 1/4-20 inch Self Tapping screws.

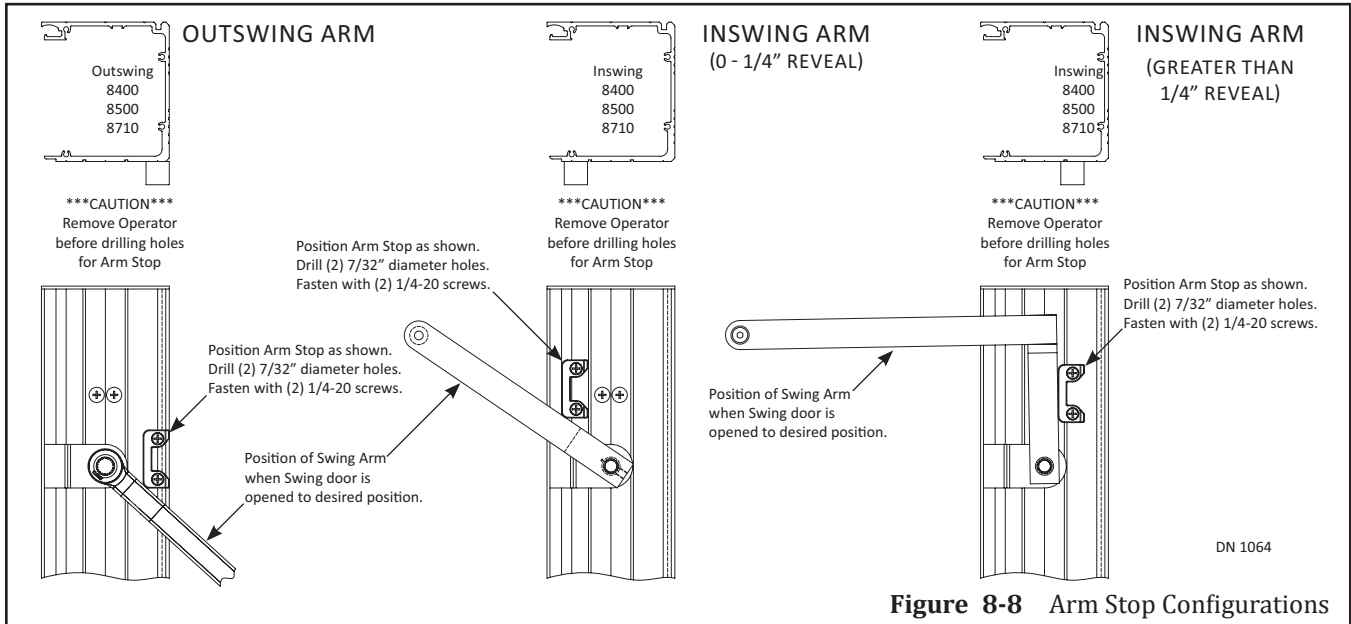
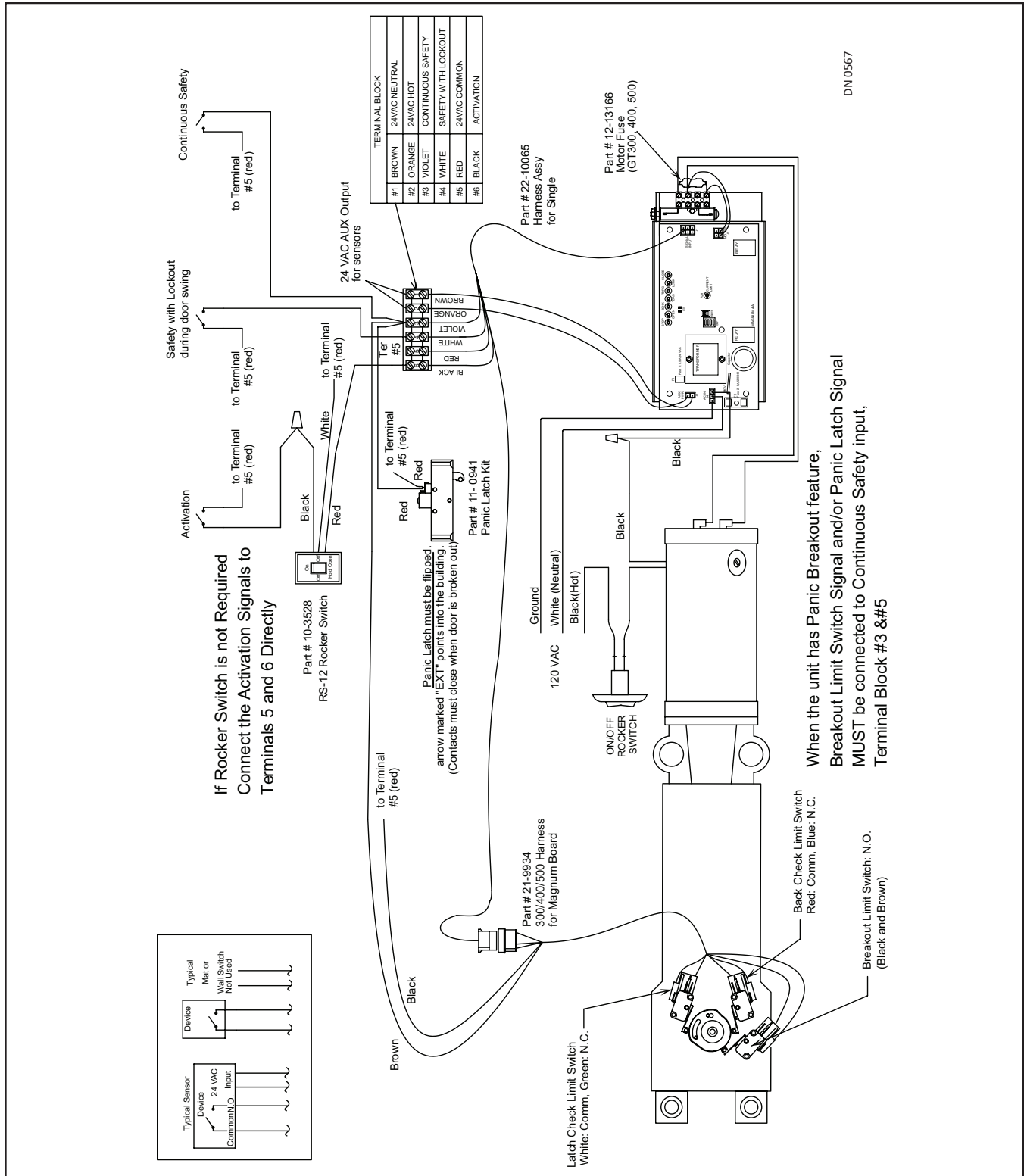

Figure 8-8 Arm Stop Configurations

CHAPTER 9: MAGNUM GENERAL WIRING

Section 9a: GT-400-500-600-8400-8500-8600 Single Swing Door



CHAPTER 10: ADJUSTMENTS

10.1 Pre-Load Adjustments

Note: Adjustments to the Cam Assembly is rarely necessary. It is recommended to adjust the Cams Assembly as a last resort.

Note: It is recommended to obtain one of the following Manuals to use as reference:

- ▶ *Magnum 4A Manual; 15-10682*
- ▶ *Analog Control Manual; 15-10745*

The Cam Assembly is preset at the NABCO factory to activate Back Check/Latch Check at 90 degrees with the Operator Spring set in the UNWOUND position.

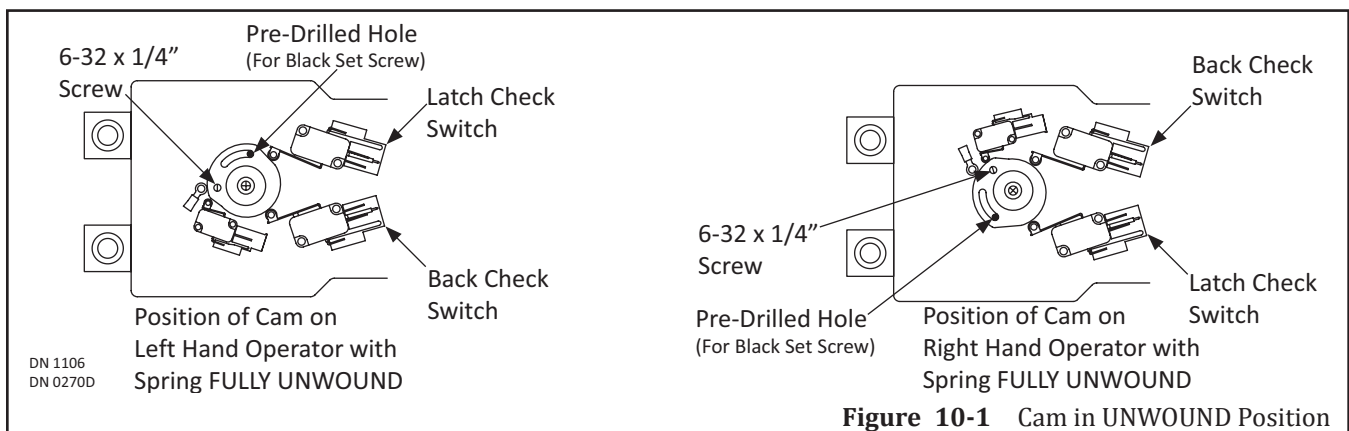

Figure 10-1 Cam in UNWOUND Position

LEFT HAND OPERATOR		RIGHT HAND OPERATOR	
MAGNUM CONTROL		MAGNUM CONTROL	
Latch Check Switch Wires	White & Green	Back Check Switch Wires	Red & Blue
Back Check Switch Wires	Red & Blue	Latch Check Switch Wires	White & Green
ANALOG CONTROL		ANALOG CONTROL	
Latch Check Switch Wires	Orange & Brown	Back Check Switch Wires	Yellow, White & Blue
Back Check Switch Wires	Yellow, White & Blue	Latch Check Switch Wires	Orange & Brown

10.1.1 Rotate the Cam for Back Check (Bottom Load Units)

1. Go to the top of Header. Remove to the Cover used to protect the access hole located directly above the Cam Assembly.
2. Go inside the Header. Remove the Cover used to protect the Cam Assembly. Set Aside.
3. Remove the 6-32 x 1/4 inch screw.
4. Go to the c-shaped slot located to the Left or Right of the 6-32 x 1/4 inch screw. Locate (1) pre-drilled hole.
5. Insert the 6-32 x 1/4 inch screw inside the pre-drilled hole.
6. Tighten, but only so the 6-32 x 1/4 inch screw does not fall out of the Slot.
7. Go to the middle of the Cam. Loosen the 10-24 x 1/2 inch screw.
8. Rotate the Cam until the appropriate Back Check position has been achieved.

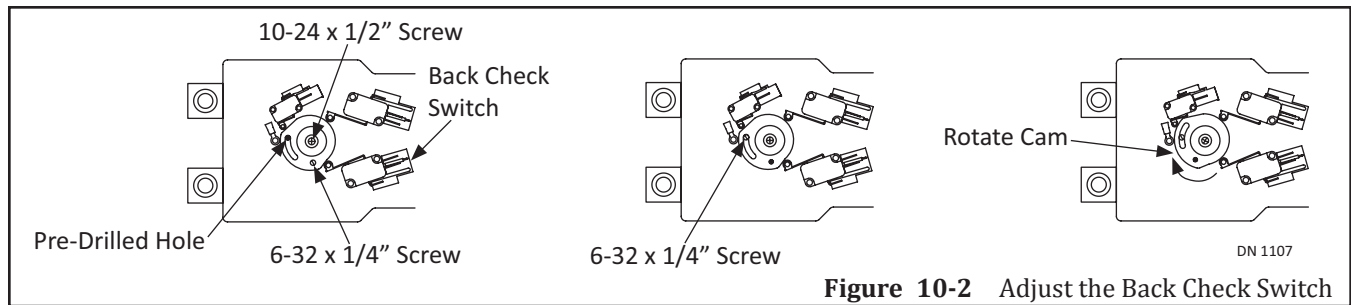

Figure 10-2 Adjust the Back Check Switch

9. Tighten down both the 6-32 x 1/4 inch screw and 10-24 x 1/2 inch screw.
10. Replace both Covers.

10.1.2 Rotate the Cam For Back Check (Side Load Units)

1. Go inside the Header. The Cam Assembly can be adjusted from the side.
 - a. A Switch Assembly Cover is not installed on a Side Load Header.
2. Remove the 6-32 x 1/4 inch screw with a 1/4 inch open end wrench.
3. Go to the c-shaped slot located to the Left or Right of the 6-32 x 1/4 inch screw. Locate (1) pre-drilled hole.
4. Insert the 6-32 x 1/4 inch screw inside the pre-drilled hole.
5. Tighten, but only so the 6-32 x 1/4 inch screw does not fall out of the Slot.
6. Go to the middle of the Cam. Loosen the 10-24 x 1/2 inch screw with a 5/16 inch box or open end wrench.
7. Rotate the Cam until the appropriate Back Check position has been achieved.
8. Tighten down both the 6-32 x 1/4 inch screw and 10-24 x 1/2 inch screw.

10.2 Adjust the Swing Arm for Latch Check

Latch Check positions can not be adjusted by rotating the Cam. Adjustments must be accomplished by removing, and then sliding the Swing Arm back onto the Operator Spindle to the left or right of the last position.

10.3 Magnum Control Adjustments

Before adjusting speeds:

- ▶ Set the Current Limit to maximum
- ▶ Adjust the Open-Close-Check speeds
- ▶ Adjust current limit to the proper level

Table 10-1 Dip Switch Information

Dip Switch	ON Position	OFF Position
1	Not Used	Not Used
2	Normally Open Safely	Normally Closed Safely
3	Push-N-Go Inactive	Push-N-Go Active
4	Timer Mode	Sequential Mode

Table 10-2 Slide Switch

Position	Function
UP	Low Energy (GT-500)
DOWN	High Energy (GT-400); Door opens faster

Table 10-3 Potentiometers and Functions

Potentiometer	Function
STOP	<ul style="list-style-type: none"> ▶ Adjusts how door reacts to continuous safety input (terminal # 3) during Opening. Counterclockwise = door slowly closes, Clockwise = door creeps open ▶ For Magnum 4 and 4A only: After 8 seconds of the door being held open, motor voltage is lowered to reduce stress on motor and control. "stop" will adjust this reduced voltage.
OPEN	Adjusts opening speed. Clockwise = Faster
BCHK	Adjusts Back Check speed. Clockwise = Faster
TDAS	Adjusts how long door remains open after activation signal. Clockwise = Longer
TDPG	Adjusts how long door remains open after Push-N-Go. Clockwise = Longer
LCHK	Adjusts Latch Check speed. Clockwise = Faster
CLOSE	Adjusts closing speed. Clockwise = Faster
Current Limit	Adjusts how hard the door will push against an obstacle (while opening) before recycling. Clockwise = less sensitive

Table 10-4 Magnum Control LED Information

LED Color	LED Status	Door Status
Green	Fast Flashing (2 flashes per second)	Door is opening.
	On Steady	Door is in Back Check.
	Slow Flashing (1 flash per second)	Door is closing.
	Off	Door is in Latch Check or Closed
Red	Indicator	Action
	Slow Flashing (1 flashes per second)	Continuous Safety Activated
	Fast Flashing (2 flashes per second)	Safety with Lockout Activated
	On Solid	Recycle Activated